

Etnyre Blackhawk Lightweight 55, 65 & 85 ton Trailers



RTN55TD3-R4A

55 tons



Storage Baskets



13 HP Honda Power Pack

- East Coast Hydraulic Booster
- Disc Brakes.

**55 Ton
Empty Weight**

Trailer	17,940#
Booster	2,460#
Total	20,400#

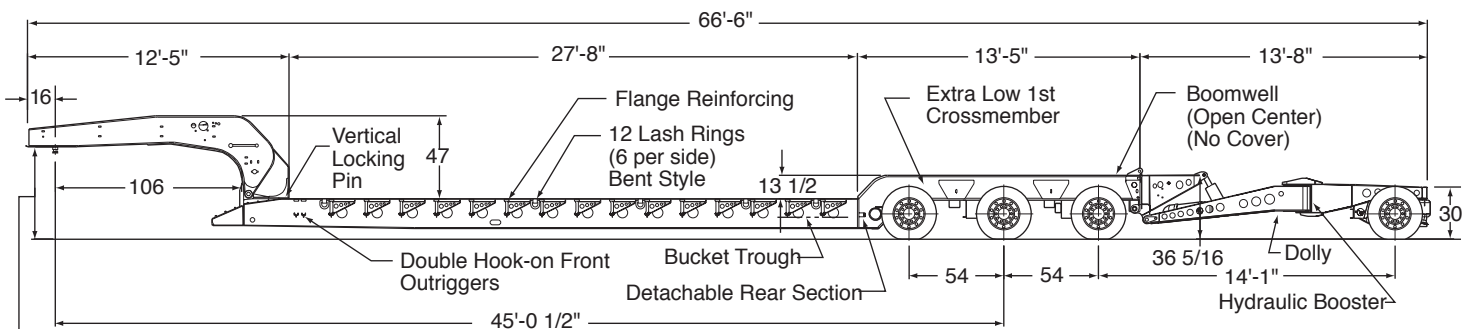

48"-50"-52"-54"
Adjustable
Loaded Fifth
Wheel Height

Drawing is for illustrative purposes only. All weights and dimensions are approximate. Trailer is shown in fully loaded condition. Platform heights will increase if loaded less than full capacity.

55 tons in any 16'
RTN55TD3-R4A



RPTN65TD3-R4/5A-RAWC



65 tons



Platform



Deck Ramps

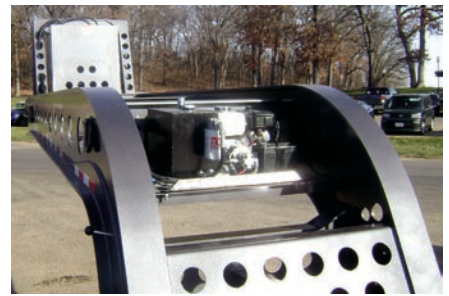

5 HP Power Pack

Capacity: 65 tons in 16' 2+3+2 or 2+2+2 w/3rd Axle Lift Configuration

- All Decks Available (Flat Floor, Drop Side, and Beam).
- Up to 30' Deck Length Available.
- Deck Extensions up to 10' in Length.
- 60" Axle Spacing Available.

65 Ton Empty Weight

Jeep	5,800#
Trailer	28,160#
Booster	5,140#
Total	39,100#

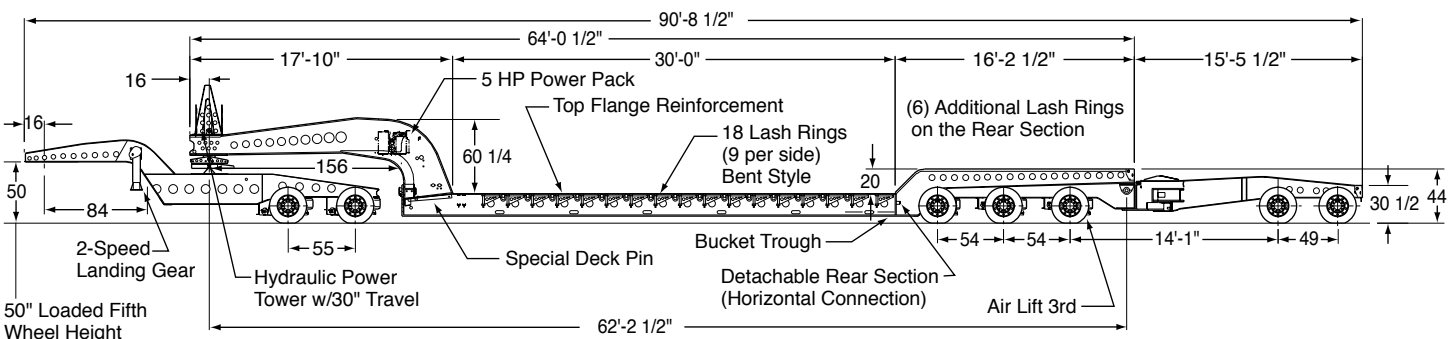

Drawing is for illustrative purposes only. All weights and dimensions are approximate. Trailer is shown in fully loaded condition. Platform heights will increase if loaded less than full capacity.

65 tons in any 12'

RPTN65TD3-R4/5A-RAWC

Etnyre RPTN85TD3-R4/5A/6A-RAWC



85 tons



Gooseneck Stand



Hydraulic Bump Steering



Light Weight Power Pack

Capacity: 85 tons in 16' 3+3+3 Configuration

- Hydraulic Power Tower (Jeep or Neck).
- Hydraulic Bump Steering (for backing empty trailer).
- Special Fifth Wheel Under Deck (for stacking empty trailer for transport).

85 Ton Empty Weight

Jeep	7,980
Trailer	37,440#
Booster	8,080#
Total	53,500#

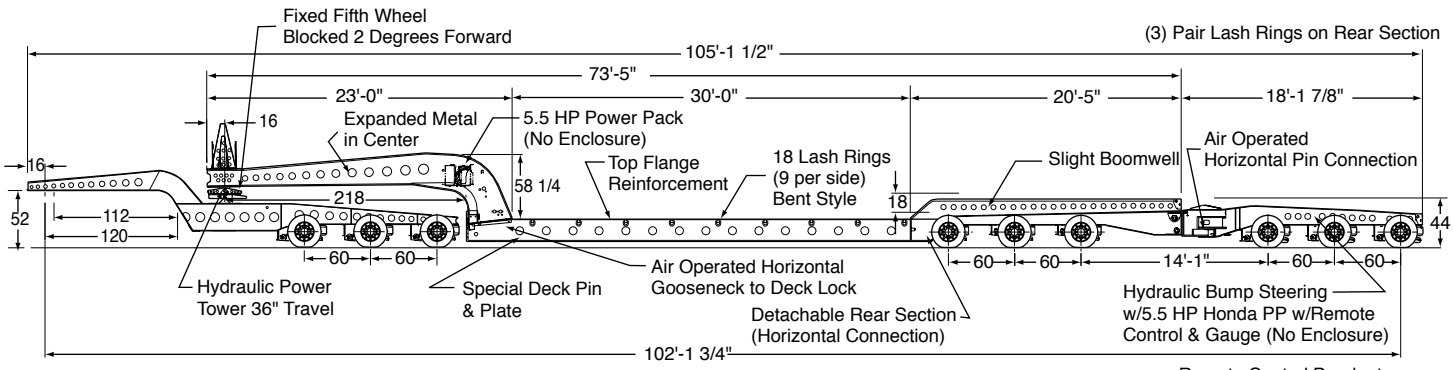

Drawing is for illustrative purposes only. All weights and dimensions are approximate. Trailer is shown in fully loaded condition. Platform heights will increase if loaded less than full capacity.

85 tons in any 16'
RPTN85TD3-R4/5A/6A-RAWC



Stackable 53' O.A.L. under 80,000# gross (depends on truck weight and deck length).



24" vertical travel hydraulic Power Tower. Lifts full load.



Disc brakes for superior braking.



Hydraulic bump steering for backing trailer.



Hydraulic Power Tower.



West coast walking beam suspension for travel over uneven terrain.

E. D. Etnyre & Co., whose policy is one of continuous improvement, reserves the right to change specifications without notice. Some items shown in photos and illustrations may be optional equipment.



E. D. ETNYRE & CO.,

1333 South Daysville Road, Oregon, Illinois 61061
 Phone: 800-995-2116 or 815/732-2116 • Fax 815-732-7400
 Web Site: www.etnyre.com • Email: sales@etnyre.com
 ISO9001:2000 certified

Distributed By:

