



M-213-04
Serial Numbers K-5995 thru K-6211

STANDARD HOPPER Series Chipsreader



Operation



Maintenance



Safety

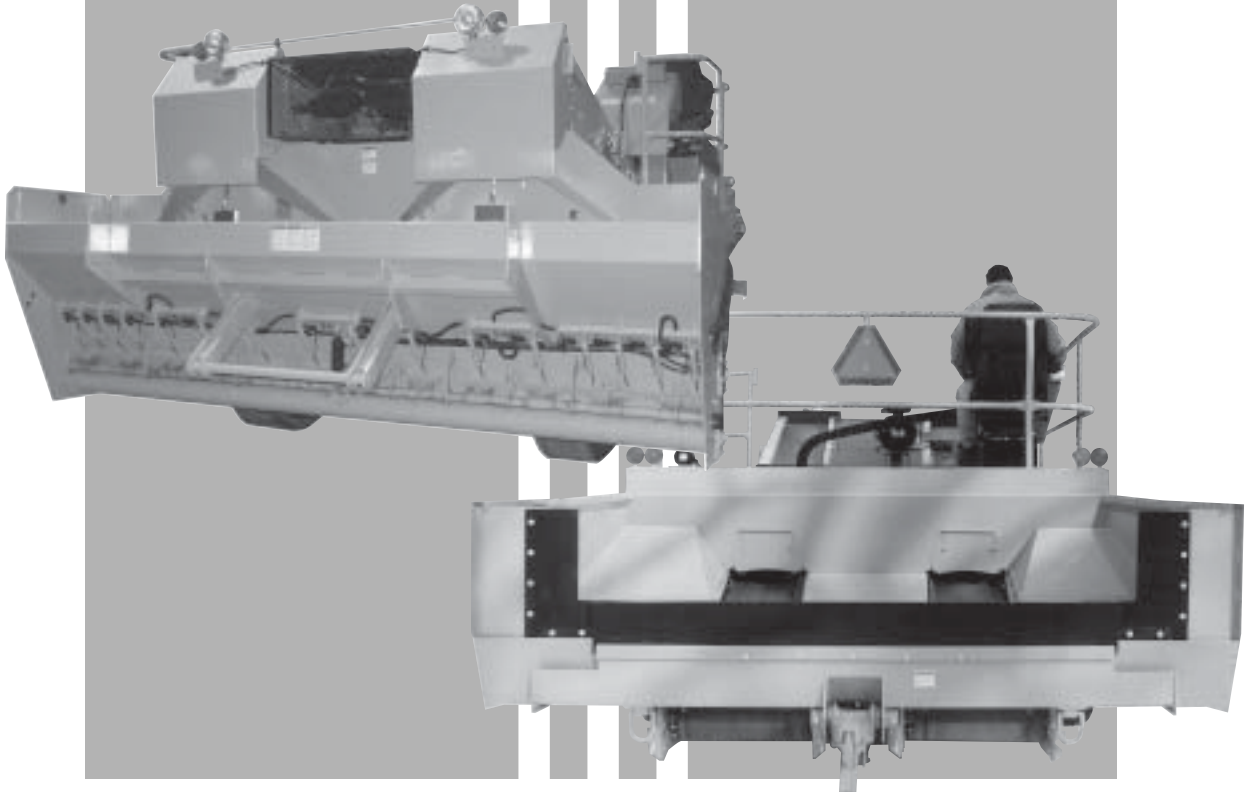

E. D. ETNYRE & CO. 1333 S. Daysville Road, Oregon, Illinois 61061
Phone: 815/732-2116 or 800/995-2116 • Fax: 800-521-1107 • www.etnyre.com



WARNING

Do not use this machine for any operation which is not described in this manual. If you have any questions about operation of this machine, contact the Etnyre Service Department at 1-800-995-2116 or 1-815-732-2116. Operations that are not approved could cause serious injury or death.

PROPOSITION 65 WARNING

Diesel Engine exhaust and some of its constituents are known to the State of California to cause cancer, birth defects, and other reproductive harm.

Please note this warning and remember -

Always start and operate the engine in a well-ventilated area;

If in an enclosed area, vent the exhaust to the outside;

Do not modify or tamper with the exhaust system.



WARNING

Fluoroelastomer handling

Some "O" rings and seals used in this vehicle are made from fluoroelastomers. When used under design conditions, fluoroelastomers do not require special handling. However, when fluoroelastomers are heated to temperatures beyond their design temperature (around 600 degrees Fahrenheit), decomposition may occur with the formation of hydrofluoric acid. Hydrofluoric acid can be extremely corrosive to human tissue if not handled properly.

A degraded seal may appear as a charred or black sticky mass. Do not touch either the seal or the surrounding equipment without wearing neoprene or PVC gloves if degradation is suspected. Wash parts and equipment with 10% lime water (calcium hydroxide solution) to neutralize any hydrofluoric acid.

If contact with the skin occurs, wash the affected areas immediately with water. Then rub a 2.5 calcium gluconate gel into the skin until there is no further irritation, while seeking prompt medical attention.

Note to physicians: For advice or treatment of HF Burns, call the DuPont Medical Emergency Number 1-800-441-3637.

M-213-04

Computerized Standard Hopper CHIPSPREADER

Operation, Maintenance and Safety Manual

for Hydrostatic Drive Units with Standard Hopper

WARRANTY

E. D. Etnyre & Co. warrants to the original Purchaser, its new product to be free from defects in material and workmanship for a period of twelve (12) months after date of delivery to original Purchaser. The obligation of the Company is limited to repairing or replacing any defective part returned to the Company and will not be responsible for consequential damages or any further loss by reason of such defect.

The company excludes all implied warranties of merchantability and fitness for a particular purpose. There are no warranties, express or implied, which extend beyond the description of the goods contained in this contract.

This warranty does not obligate the Company to bear the cost of machine transportation in connection with the replacement or repair of defective parts, nor does it guarantee repair or replacement of any parts on which unauthorized repairs or alterations have been made or for components not manufactured by the Company except to the extent of the warranty given by the original Manufacturer.

This warranty does not apply to:

- (1) Normal startup services, normal maintenance services or adjustments usually performed by the selling dealer, factory service representative or customer personnel.
- (2) Any product manufactured by E. D. Etnyre & Co. purchased or subjected to rental use.
- (3) Any product or part thereof which shows improper operation, improper maintenance, abuse, neglect, damage or modification after shipment from factory.
- (4) Any product or part thereof damaged or lost in shipment. Inspection for damage should be made before acceptance or signing any delivery documents releasing responsibility of the delivering carrier.

This warranty and foregoing obligations are in lieu of all other obligations and liabilities including negligence and all warranties of merchantability or otherwise, express or implied in fact or by law.

HOW TO ORDER PARTS

To assure prompt delivery when ordering parts, please furnish the following information: **1)** Complete name and address of consignee. **2)** Method of shipment preferred. **3)** Is shipment to be prepaid or collect? **4)** Serial numbers of units to which parts apply. **5)** Complete part numbers and descriptions. **6)** Any special instructions. Part numbers beginning with 9250000 are category numbers and must include descriptive term to complete the order (such as, length, color, etc.). These items when listed in the parts manual will indicate what information must be included.

SPECIFY UNIT SERIAL NUMBER WHEN ORDERING PARTS!



E. D. ETNYRE & CO., Oregon, Illinois 61061-9778
1333 South Daysville Road Phone: 815/732-2116 Fax: 815-732-7400

**WARNING**

Do not use this machine for any operation which is not described in this manual.

If you have any questions about operation of this machine, contact the Etnyre Service Department at 1-800-995-2116 or 1-815-732-2116.

Operations that are not approved could cause serious injury or death.

**WARNING****FLUOROELASTOMER HANDLING**

Some O-rings and seals used in this vehicle are made from fluoroelastomers, When used under design conditions, fluoroelastomers do not require special handling. However, when fluoroelastomers are heated to temperatures beyond their design temperature (around 600° Fahrenheit), decomposition may occur with the formation of hydrofluoric acid. Hydrofluoric acid can be extremely corrosive to human tissue if not handled properly.

A degraded seal may appear as a charred or black sticky mass, Do not touch either the seal or the surrounding equipment without wearing neoprene or PVC gloves if degradation is suspected. Wash parts and equipment with 10% lime water (calcium hydroxide solution) to neutralize any hydrofluoric acid.

If contact with the skin occurs, wash the affected areas immediately with water. Then rub a 2.5 calcium gluconate gel into the skin until there is no further irritation, while seeking prompt medical attention.

Note to Physicians: For advice or treatment of HF burns, call the DuPont Medical Emergency number, 1-800-441-3637

**Safety Precautions,
Hazard Seriousness Level**

You will find safety information boxes throughout this manual. These boxes contain information alerting you to situations or actions to avoid.

Signal words (DANGER, WARNING and CAUTION) are used to identify levels of hazard seriousness. Their selection is based on the likely consequence of human interaction with a hazard. Definitions of hazard levels are as follows.



DANGER - Immediate hazards which **will** result in severe personal injury or death.



WARNING - Hazards or unsafe practices which **could** result in severe personal injury or death.



CAUTION - Hazards or unsafe practices which could result in minor personal injury or product or property damage.

CALIFORNIA**Proposition 65 WARNING**

Diesel engine exhaust and some of its constituents are known to the State of California to cause cancer, birth defects, and other reproductive harm.

Please note this warning and remember -

Always start and operate the engine in a well ventilated area;

If in an enclosed area, vent the exhaust to the outside;

Do not modify or tamper with the exhaust system.

Table Of Contents

Safety Precautions,	2	Engine Diagnostics Wait To Start Light	16
Hazard Seriousness Level	2	Engine Diagnostics Maintenance Light	17
Table Of Contents	3	Engine Diagnostics Water In Fuel Light	17
List Of Figures	4	Individual Gates Master Switch	17
General Identification	5	Left Hopper Gate Selector Switches	17
Introduction	6	Right Hopper Gate Selector Switches	17
Reporting Safety Defects	6	Brake Pedal	17
Check Out	6	Left Conveyor Switch	17
Attaching Hopper To Unit	7	Right Conveyor Switch	17
Safety Precautions:	7	Hitch Release Pushbutton	17
Attaching Hopper to Unit	7	Gate Override Switch	17
Identification and Function of Controls	9	Operation	19
Power/Ignition Switch	9	Automatic Conveyor Control	19
Mode Selector-Drive/Park	9	Belt Speed Controls	19
Speed Set Toggle Switch	9	Backup Alarm	19
Aggregate Size Switch	9	Hydraulic Powered Seat Assembly	20
Application Rate Switch	10	Extra Agitator	20
Circuit Breakers	10	Segregation Screen	20
Computer Display Screens	11	Appendix A	21
Operator Screens	11	Maintenance Adjustments	21
Screen Scroll Switch	13	Hopper Spread Roll Wear Plate Adjustment	21
Speed/Direction Control Handle	13	Hopper Gate Wear Plate Adjustment	21
Gate/Spread Roll Switch	14	Conveyor Belt Adjustment	22
Turn Signal Selector and Indicators	14	Towing Instructions	23
Hazard Flasher Switch	14	Appendix B	24
Headlight Switch	14	Computer Setup	24
Seat Shift Switch	14	Set Up Screens	24
Hitch Release Pushbutton	14	Appendix C	27
Strobe/Beacon Switch (Optional)	15	Computer Service Screens	27
Application Rate Computer	15	Systems Startup And Adjustments	32
Right Conveyor Selector	15	Hydrostatic System Startup	32
Left Conveyor Selector	15	Gate Transducer Adjustment	33
Hitch Height Switch	16	Air Pressure Adjustments	34
Gate Override Switch	16	Pressure Settings For Hydrostatic Drive Pump	35
Memory Selector Buttons	16	Setting the Charge Pressure	36
Memory Save Button	16	Pressure Settings For Auxiliary Pump	36
Calibrate Switch	16	Relief Valve Settings	36
Horn	16	Pressure/Flow Settings For Actuator Valving	37
Batwing Switch	16	Gate Cylinder Relief Valve	37
Warning Light	16	Spreadroll Speed Adjustment	38
Filter Indicator	16	Conveyor Speed Adjustment	38
Traction Control Switch	16	Fixed Displacement Auxiliary Pump	38
Throttle Run/Idle Switch	16	Pressure Settings For Actuator Valving	38
Throttle Increase/Decrease Switch	16	Main Relief Pressure (MP)	38
Auxiliary 12 Volt Power	16	Pilot Pressure (PP)	39
Engine Diagnostics On/Off Switch	16	Reduced Pressure (RP)	39
Engine Diagnostics Increase/Decrease Switch	16	Truck Hitch Arrangement	40
Engine Diagnostics Stop Light	16	Caution And Instruction Plates	41
Engine Diagnostics Warning Light	16	Lubrication	42

List Of Figures

Figure 1. Front Of Chipsreader	7	Figure 17. Hopper Gates	21
Figure 2. Rear Of Hopper	7	Figure 18. Conveyor Tail Pulley	22
Figure 3. Hopper	8	Figure 19. Conveyor Head Pulley Adjustment	23
Figure 4. Hopper Gates	8	Figure 20. Hydrostatic Pump	32
Figure 5. Control Console Identification	10	Figure 21. Engine Left Side	32
Figure 6. Speed/Direction Control Handle	13	Figure 22. Suction Filters	33
Figure 7. Ground Speed Pickup	14	Figure 23. Hopper Transducer	34
Figure 8. Control Panel	15	Figure 24. Air System	34
Figure 9. Conveyor Hood and Flow Deflector	19	Figure 25. POR Setting	35
Figure 10. Hopper Chain Drive	19	Figure 26. High Pressure Relief Setting	35
Figure 11. Material Level Paddle	20	Figure 27. Charge Pressure Adjustment	36
Figure 12. Belt Speed Controls	20	Figure 28. Pumps	36
Figure 13. Segregation Screen	20	Figure 29. Conveyor Manifold	37
Figure 14. Driver Control Station	20	Figure 30. Gate Relief Valve	38
Figure 15. Spread Roll Wear Plate	21	Figure 31. Conveyor Manifold	38
Figure 16. Gate Wear Plate	21	Figure 32. Hydraulic Control Assembly	39

General Identification

Ref	Qty	Description
1	2	Conveyor Drive Motors
2	1	Valve
3	2	Material Control Paddle
4	1	Gate Transducer
5	AR	Gates
6	1	Hydraulic Reservoir
7	1	Front Axle Drive
8	2	Suction Filter
9	1	Front Hydraulic Motor
10	1	Rear Hydraulic Motor
11	1	Rear Axle Drive (4WD Shown)
12	2	Hitch Position Linkage
13	2	Tail Pulley Asm
14	2	Head Pulley Asm
15	1	Hitch Release Cylinder
16	1	Manifold-Hitch/Pwr Steer/Brake
17	3	Hydraulic Pumps
18	1	Radiator
19	2	Return Filter
20	1	Gate Actuating Cylinder
21	1	Manifold-Conveyor/Spreadroll
22	2	Conveyor Hood
23	2	Head Light
24	1	Hopper Asm
25	2	Hopper Latch Pin
26	2	Rough Tread Step
27	2	Tail Light
28	1	Back Up Alarm
29	1	Fuel Tank
30	1	Hitch
31	AR	Rear Lining
32	AR	Flashing
33	2	Material Separator
34	1	Slow Moving Emblem
35	4	Handrails
36	1	Seat Assembly
37	1	Control Console Asm
38	AR	Rough Tread
39	1	Air Intake Asm
40	2	Conveyor Belt
41	1	Hitch Release
42	10	Engine/Conveyor Covers/Decking
43	1	Horn

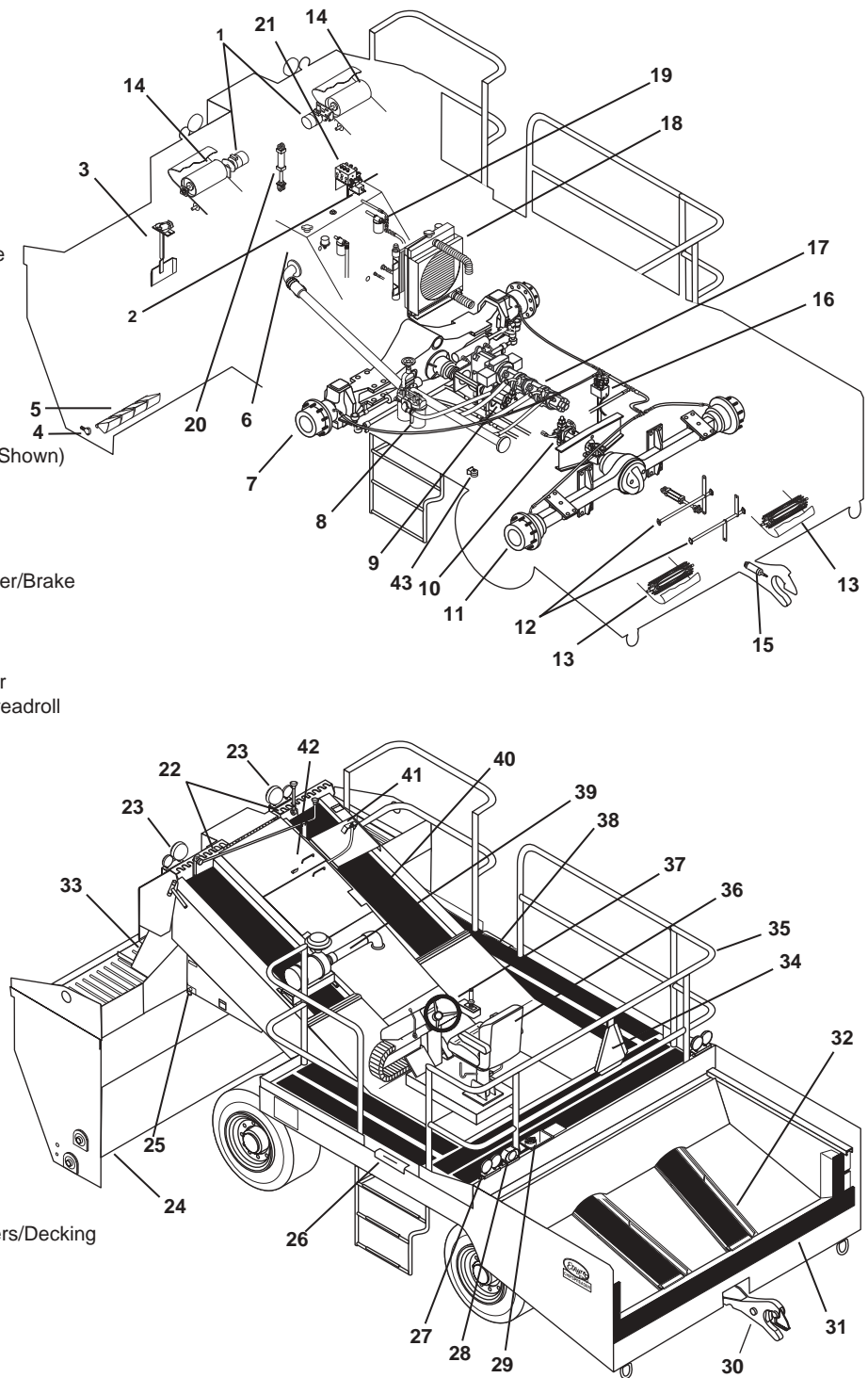

Introduction

The Etnyre Computer Controlled Hydrostatic ChipSpreader has been designed to improve the accuracy of chip spreading while improving productivity and simplifying the operation. This has been done by incorporating Application Rate capabilities using precise gate opening control and speed feedback in closed loop controls.

It is especially important from the safety standpoint that this manual be thoroughly read and understood before performing any operational or maintenance function.

The information contained in this manual will enable you to better understand the operation and performance of the machine and thus better utilize it to obtain maximum performance from your ChipSpreader.



WARNING

Unsafe operation of equipment may cause injury. Read, understand and follow the manuals when operating or performing maintenance

IMPORTANT

1. The optional front hopper segregation screen should be up when the unit is traveling between job sites to avoid possible damage to the screen.
2. Keep the ChipSpreader on the road or relatively uniform surface at all times to avoid loss of traction and/or possible damage to the front hopper or rear of conveyors.
3. Place truck gearshift in neutral as soon as the truck is connected to the spreader.
4. Under most operating conditions the ChipSpreader should be allowed to tow the truck. However, certain steep upgrade or downgrade conditions may require the truck to assist the ChipSpreader. The ChipSpreader must pull the truck even while the truck is assisting. Do not attempt to push the ChipSpreader with the truck.
5. Do not tow or push the ChipSpreader before reading the towing instructions contained in this manual as this may damage the hydraulic motors.
6. Never use the ChipSpreader to dislodge a truck or other equipment which has become stuck in mud or soft shoulder conditions as this may cause damage to the hitch, which could fail later in normal operation.
7. Avoid roading the machine with material in the

hoppers if at all possible. Added weight in either hopper increases stopping distance.

8. After changing filters or working on the hydrostatic system, be sure to follow hydrostatic start up procedure to reduce the potential for damage to the hydrostatic system.

9. Always install locking control box cover & chock wheels when leaving machine unattended as protection against vandalism and accidental movement.

10. Before operating the ChipSpreader, do an inspection of the machine for condition of the tires, fluid leaks, fluid levels, fuel level, loose bolts, improper hose routings etc. be sure that the machine is in a safe condition to operate.

Reporting Safety Defects

If you believe that your vehicle has a defect which could cause a crash or could cause injury or death you should immediately inform the National Highway Traffic Safety Administration (NHTSA) in addition to notifying E. D. Etnyre & Co.

If NHTSA receives similar complaints, it may open an investigation, and if it finds that a safety defect exists in a group of vehicles, it may order a recall and remedy campaign. However, NHTSA cannot become involved in individual problems between you, your dealer, and E. D. Etnyre & Co.

To contact NHTSA, you may either call the Auto Safety Hotline toll-free at 1-800-424-9393 (or 366-0123 in Washington, D.C. area) or write to: NHTSA, US. Department of Transportation, Washington, D.C. 20696. You can also obtain other information about motor vehicle safety from the hotline.

Check Out

1. The following accessories are shipped with each ChipSpreader: extra linkage rods for shortened truck hookup, agitator disconnect bolt, parts book and operation, maintenance and safety manual, wiring and hydraulic diagrams, and engine parts and operator's manual.
2. Best performance for most operating conditions is achieved when tire pressures are set to 55 to 60 PSI in front and 60 to 65 PSI in rear. However, various op-

erating speeds, road bed conditions, truck pulling arrangements and other operating conditions may require different tire pressures.

⚠ WARNING

Never exceed the maximum inflation pressures indicated on the tire's sidewall.

3. Grease all fittings and check all reservoir oil levels in accordance with the ChipSpreader Lubrication Chart on the side of the tool box, prior to operation.

4. Check engine coolant and oil levels prior to operation. Refer to engine operator's maintenance manual for complete engine service requirements.

Attaching Hopper To Unit

Safety Precautions:

Before lifting hopper, check to ensure that adequate clearance will be maintained between the lifting machine and overhead electrical lines. you must maintain at least 10 feet of clearance.

Ensure that the hopper is well secured and rigged before starting any lifting operation.

Ensure that the area around the hopper is clear of personnel and equipment and only trained personnel are used to assist in installing the hopper.

Never let anyone go under the hopper while it is suspended.

Ensure that hands and feet are kept clear of the hopper and potential pinch points on front of the ChipSpreader during installation.

Attaching Hopper to Unit

1. By hooking a lifting sling into the rear lifting eye, the hopper can be tilted forward while being raised, allowing the hopper carrying shafts to engage the hopper carrying arms on the ChipSpreader. (Figure 1 & 2) Lower hopper slowly until lifting sling can be disconnected.

2. Attach lifting device to front lifting attachment and raise hopper to vertical position.

3. Install hopper pins, in front of latch arms, through pin catch.

4. Always install latch pin lock pins and snap down

rings properly prior to releasing the lifting device

5. Uncouple spread roll hoses and couple to hopper drive motor hoses. Use caution to wipe each half of each connector clean before connecting. *Dirt and contaminants can cause major damage to the hydraulic systems.*

6. Hopper gate adjustment and spread roll straightness are established at the factory. However, to be sure adjustments or straightness were not altered during shipment and storage, the following gate and spread roll adjustment checks should be performed prior to operation:

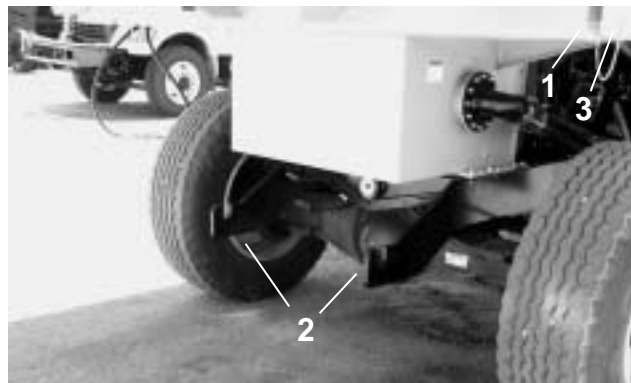

Figure 1. Front Of Chipspreader

1. Pin Catch 2. Hopper Pin 3. Carrying Arms



Figure 2. Rear Of Hopper

1. Carry Shaft 2. Latch Arms (2) 3. Hopper 4. Front Lifting Eye

Check that the gate opening cylinder rod clevis is fully screwed onto the cylinder rod.

With the hopper on the machine, start the engine and run it at a minimum of 2000 rpm.

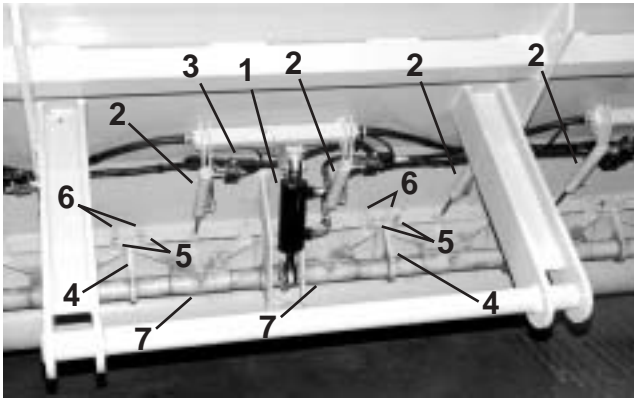

Figure 3. Hopper

- | | |
|-----------------------|--------------------|
| 1. Hydraulic Cylinder | 5. Gate Open Stop |
| 2. Air Cylinder | 6. Gate Close Stop |
| 3. Air Valve | 7. Gate |
| 4. Buss Arm | |

Depress and hold the gate override push button until the gates are at the full open position. Release the pushbutton and the gates will return to the closed position. There should be 1/16" clearance between the gates and the spread roll. If this clearance is not constant across the full width of the hopper, it indicates that the wear plates may need to be adjusted or the spread roll is not straight. Contact the factory for straightening instructions.

Important

1. Since the ChipSpreader is designed to operate on new sealcoat surfaces, all dynamic braking is being done by the hydrostatic system. With abrupt control inputs it is possible to "scuff" the road surface during starting or stopping. However, with smooth application of control inputs, very precise accelerations and decelerations can be made, giving the ability to outperform a conventional clutch/brake/gear combination.

2. Friction characteristics on both new sealcoat surfaces and other surfaces vary considerably. Therefore stopping distances must be watched carefully, particularly when towing a truck, going downhill, or in stopping from higher travel speeds.

3. The larger the truck or steeper the grade, the longer the stopping distance.

4. Traveling with the front hopper loaded removes weight from the rear wheels thus reducing the braking effectiveness of the rear wheels, while the additional weight increases the braking forces required. Carrying

material in the rear hopper also increases the braking forces required and consequently increases the required stopping distance from a given speed. It is therefore highly recommended to travel or "road" the machine in an empty condition.

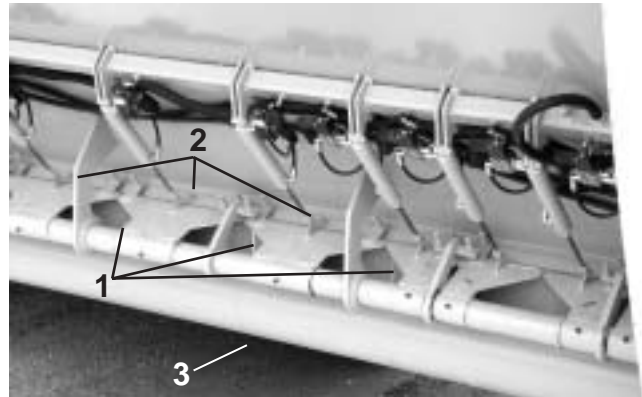

Figure 4. Hopper Gates

- | | | |
|----------|---------------------|----------------|
| 1. Gates | 2. Adjustment Bolts | 3. Spread Roll |
|----------|---------------------|----------------|

5. When operating with the truck, in some cases, such as on steep downgrades, the truck should assist in braking. The truck should always set its own brakes after stopping, regardless of whether the combination is stopped on a downgrade, upgrade or level. The braking effort must be a coordinated effort when required. It is therefore important to have a clearly understood means of communication between the ChipSpreader and truck. This may be done by radio, hand signals, horns etc. Each truck driver should know who is to give signals, where to look for the signal and the meaning of each signal.

WARNING

Stay off hopper while machine is moving.
Machine movements could cause a fall
resulting in injury or death.

Identification and Function of Controls

Refer to figure 5 for identification of described features.

1. Power/Ignition Switch

Rotating from “off” to “on” supplies electric power to all systems and controls. Rotating the switch further to the right against the spring will engage the starter. When the engine runs, release the key and the switch will remain in the “on” position.

SINCE ALL FUNCTIONS EXCEPT POWER STEERING, REAR BRAKES AND FRONT BRAKES (2WD ONLY) ARE ELECTRICALLY CONTROLLED, TURNING THE KEY TO “OFF” RESULTS IN AN EMERGENCY STOP.



WARNING

Turning ignition switch to “off” results in emergency stop.

SHUT MACHINE OFF AND WAIT FOR ALL MOVEMENT TO STOP BEFORE LEAVING OPERATOR’S SEAT OR SERVICING.

FAILURE TO DO SO COULD RESULT IN UNEXPECTED MOVEMENT AND CAUSE SERIOUS INJURY OR DEATH

2. Mode Selector-Drive/Park

A two position switch selects either “drive” or “park” position.

In “Park” mode, the “speed/direction handle”, (9) is disabled and the parking brake is applied. The parking brake is applied when the chipsreader is stopped by returning the speed/direction handle to neutral, regardless of the position of the “Drive/park” switch.

In the “Drive” position, the parking brake will release when the “speed/direction handle”, (9) is moved from the neutral position resulting in forward or reverse motion of the chipsreader.

Since engaging “park” disables “speed/direction handle” and applies the parking brake, selecting park while the chipsreader is moving will result in an emergency stop. Do not select “park” unless the chipsreader is at a full stop.

Auxiliary computer power is routed through the Park/ Drive switch/ When the engine is not running, place the switch in the Park position to avoid draining the batteries.



WARNING

Selecting “park” while the chipsreader is moving results in an emergency stop.

CAUTION! ALWAYS PLACE THE MODE SELECTOR SWITCH IN THE “PARK” POSITION WHEN THE CHIPSREADER IS STOPPED TO AVOID ACCIDENTAL MOVEMENT OF THE MACHINE.

3. Speed Set Toggle Switch

When in the “Drive” position, this switch provides the command signal (or set point) to the computer. This switch is used to set the desired ChipSpreader speed in feet per minute. Pushing the toggle switch up will increase the speed set point, while pushing the toggle switch down will decrease the speed set point. The computer display screen will display the set point until the control handle is moved out of neutral, and then it will display the actual speed. Once the speed is set, the ChipSpreader will repeat that speed any time the control handle is pushed fully forward. The “Speed Set Toggle Switch” can be pushed to either increase or decrease the set point while the ChipSpreader is moving. When this is done, the ChipSpreader will smoothly transition to the new set point, and the display will display the set point rather than the actual speed. When the switch is released, the display will switch back to the actual speed.

If the engine cannot maintain the chipsreader’s speed on a steep hill, bring the control handle rearward toward neutral to slow the ChipSpreader down so that the engine can recover to high idle rpm, and when the steepness of the hill decreases, or the truck lightens up, push the control handle fully forward again to “engage” the automatic speed holding feature.

4. Aggregate Size Switch.

This switch (4) selects the size of the aggregate to be spread. The size should be set to the size of the aggregate to be spread before setting the application rate and doing any calibrating of material.

The choices of aggregate size are: Sand, 1/4” Chips, 3/8” Chips, 3/8” Gravel, 5/8” Chips, and 1” Chips.

The amount of aggregate applied on the ground (application rate) is a function of the front hopper gate opening. The gate opening is determined by the selected aggregate (i.e. 3/8 chips) and the chipsreader speed. The computer controls the gate opening to maintain the application rate (i.e. 20.0 lbs/yd²).

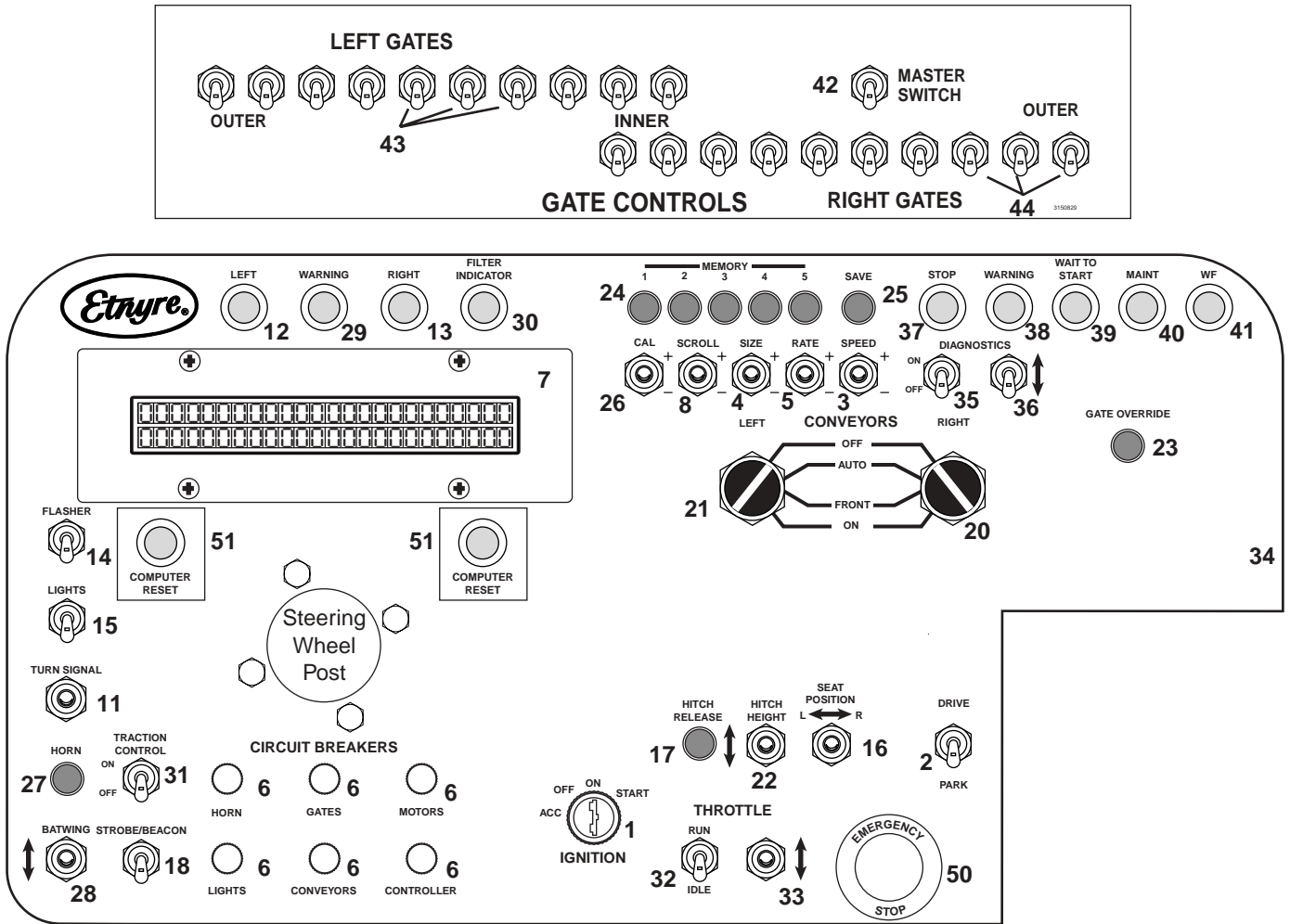

Figure 5. Control Console Identification

- | | | |
|---------------------------------------|---------------------------------|--------------------------------------|
| 1. Power/Ignition Switch | 2. Mode Selector-Drive/Park | 3. Speed Set Toggle Switch |
| 4. Aggregate Size Switch | 5. Application Rater Switch | 6. Circuit Breakers |
| 7. Computer Display Screen | 8. Screen Scroll Switch | 11. Turn Signal Switch |
| 12. Right Turn Signal Indicator | 13. Left Turn Signal Indicator | 14. Hazard Flasher Switch |
| 15. Headlight Switch | 16. Seat Shift Switch | 17. Hitch Release Pushbutton |
| 18. Strobe/Beacon | 22. Hitch Height Switch | 20. Right Conveyor Control Selector |
| 21. Left Conveyor Control Selector | 25. Memory Save Button | 23. Gate Override Switch |
| 24. Memory Selector Buttons | 28. Batwing Switch | 26. Calibrate Switch |
| 27. Horn Button | 31. Traction Control | 29. Warning Light |
| 30. Filter Indicator | 32. Throttle Run/Idle Switch | 35. Engine Diagnostics On/Off Switch |
| 33. Throttle Increase/Decrease Switch | 34. Auxiliary 12VDC Power | 38. Engine Warning Light |
| 36. Engine Diagnostics Inc/Dec | 37. Engine Stop Indicator Light | 41. Water In Fuel Indicator Light |
| 39. Engine Wait To Start Light | 40. Engine Maintenance Light | 44. Right Side Gate Switches |
| 42. Gate Master Switch | 43. Left Side Gate Switches | |
| 50. Emergency Stop Switch | 51. Computer Reset Switch | |

5. Application Rate Switch.

This switch sets the position to which the gates will open by increasing or decreasing the set point. The set point is the application rate, in lbs/yd², that will be delivered when the Gate/Spread Roll switch (10) is activated. Pushing the switch up will increase the set point while pushing the switch down will decrease the set point. The set point can be changed at any time whether spreading aggregate or not.

6. Circuit Breakers.

These circuit breakers are powered from the accessory post on the ignition switch and lose voltage when the starter is engaged.

Light circuit breaker: Supplies power to all lights except brake lights.

Conveyor circuit breaker: Supplies power to conveyors and augers

Controller circuit breaker: Supplies power to hopper in/out, gate override, hitch release, hitch height, and seat position functions.

These circuit breakers are powered from the ignition post on the ignition switch and maintain voltage while starter is engaged.

Horn circuit breaker: Supplies power to the horn and the front control box.

Gate circuit breaker: Supplies power to the joystick and individual gates when required.

Motor circuit breaker: Supplies power to the motors and all relays.

The computer is fused with an inline, 20 amp fuse and is powered from the accessory post on the ignition switch.

7. Computer Display Screens

Operator Screens

20.0	3/8	400
lbs/yd²	Chip	fpm

The screen shown above is displayed when power is turned on to the computer. This screen shows the application rate set point, aggregate size, and the speed set point while at a stand still. These values can all be changed depending on the application as described in earlier sections. When the chipsreader is powered down, the values currently on the screen are saved and returned the next time power is turned on.

The speed setpoint is displayed while the chipsreader is not moving. Once the chipsreader is in motion, the actual speed is displayed. The speed feedback is generated by a magnetic pickup mounted on the motor output shaft which generates pulses which the computer displays as feet per minute (FPM).

Different configurations of these three values can be saved in one of five memory presets. The memory presets store an application rate set point, an aggregate, and a speed set point in one of the memory locations. The memory pushbutton then restores the information stored in that location to the screen when activated. This allows the operator to switch between stored combinations with the push of a button as opposed to having to scroll the individual values.

It is important to understand that the memory functions simply restore the selected values to the operators screen. If one of the values is changed while operating the values stored in the memory will not change. Pressing the memory pushbutton will restore the saved values and overwrite the changed speed setpoint.

To save information in a memory, adjust the application rate set point, the aggregate size, and the speed set point to values that will be commonly used together. When the values displayed on the screen are set to the

desired values, press the save pushbutton. Activating the save pushbutton will change the display to read "Select location 1, 2, 3, 4 or 5". Select the location, or memory, the information is to be stored in by pressing the corresponding memory pushbutton (i.e. memory 1). The display will return to the main operator screen depicted above when this has been done. As a check, press the memory pushbutton the information was saved to prompting the display to read "Restoring memory 1". The display will then show the values saved in memory 1.

Certain material conditions could require a calibration of the computer to insure the application rate set point is equal to the actual application on the ground. It is important to understand that the aggregate is being calibrated and not the memory. For example, if 3/8 chips are saved in memory 1 with an application rate setpoint of 20.0 lb/yd² and also in memory 2 with an application rate of 8 lb/yd², a calibration of 3/8 chips will update both memory locations. The memory functions serve as a means to quickly change between frequently used operating parameters.

If the set point on the display is dramatically different from the application on the ground it is possible the incorrect aggregate has been selected. Assuming this is not the case, the following procedure should be used to calibrate the aggregate to correct the application rate information stored in the computer.

Before calibrating a material, verify that the spread roll is turning at 113 rpm. The aggregate to be calibrated needs to be selected on the display (i.e. 3/8 chips). Set the application rate setpoint to the desired value (i.e. 20 lb/yd²). The speed setpoint should be set around 300 FPM. Using the canvas supplied, place on a flat surface leaving plenty of room for the chipsreader to get up to speed. With the control handle in the full forward position to assure constant speed, maneuver the chipsreader towards the canvas. Actuate the gate thumbswitch about 10 feet before the material will hit the canvas to insure the gate is in the correct position. Deactivate the gate thumbswitch once the canvas is covered. Weigh the material and the canvas with the scale provided. Empty the canvas and weigh it empty. Subtract the empty canvas weight from the total weight to arrive at the pounds per square yard. Do this a minimum of 3 times and average the values before making any changes.

Compare the measured values against the application rate setpoint on the display to determine calibration required for the hopper. As an example, assume the hopper weighed in at 23.5 lbs. Press the cal switch

up or down to access the calibration screens. The screen will now read:

0.0 **95.6%**
lb/yd² **RIGHT CAL**

The program is universal for variable and standard hoppers. The standard hopper uses the left hopper screens for calibration, so you must scroll past the right hopper screen.

Press the scroll switch down (-) to access the calibration screen for the left hopper which displays the following:

0.0 **95.6%**
lb/yd² **LEFT CAL**

The hopper weighed 23.5 lbs at the application rate setpoint of 20.0 lbs/yd². The measured weight is 3.5 lbs heavy compared to the setpoint. Press and hold the cal switch down (-) until the lb/yd² reads -3.5. The RIGHT CAL value will decrease as the rate is increased, and increase as the rate is decreased. The RIGHT CAL value is a density factor that serves as a reference to keep track of the calibration.

Press the save pushbutton to store the calibration for the left hopper. This process will decrease the output of the left hopper by 3.5 lbs making the output equal to the application rate setpoint. The screen will reset to zero once the pushbutton is activated.

The calibration for the hopper is now complete. To exit the calibration screens, press the scroll switch up (+) two times to return to the main operators screen. The calibration screens can be exited at any time by pressing the scroll switch without changing the calibration. The calibration is changed only by pressing the save pushbutton. The calibration process may need to be repeated depending on the accuracy desired. For very accurate calibrations (± 2.0 lbs) it will be necessary to weigh at least three samples to get an average material weight to use in the calibration process.

The calibration process will correct the hopper to spread very close to the application rate setpoint. While chipping it may become evident that the material is less than actually desired. This can be fine tuned using the calibration process explained above while chipping. If the hopper appears lighter than desired, press the cal switch and scroll to the left calibration screen. Toggle the cal switch up (+) to raise the 0.0 to 1 or 2 lbs and press the save pushbutton. This will increase the output of the hopper without effecting the right. The change

will take effect as soon as the save pushbutton is activated and should be noticeable on the ground. This process can be repeated until the material appears as desired.

The calibration process is permanent, meaning when the machine is powered down the changes will be saved for the next time the machine is put to use.

To move to the next screen, press the scroll switch down (-).

100°F **60 PSI** **15%**
WATER **OIL** **FUEL**

This screen shows the engine coolant temperature on the left, the engine oil pressure in the center, and the fuel remaining in the fuel tank on the right. To move to the next screen, push the scroll switch down (-).

100°F **2000 RPM** **13.8 V**
HYD OIL **ENGINE** **BATTERY**

This screen shows the hydraulic oil temperature on the left, the engine rpm in the center, and the system voltage on the right side. The right side will display battery voltage when the ignition is on but the engine is not running. The voltage will increase to 13.5 to 15.0 volts as the output of the alternator supplies voltage to the system. To move to the next screen, push the scroll switch down (-).

120.8 **8240 FT**
ENGINE **CHIPPED**

This screen shows the hours on the machine on the left side, and the feet chipped on the right side. When the ignition key is turned on but the engine is not running, the hours will not accumulate since the hourmeter is started and stopped by an oil pressure switch. If the engine is shut down after running less than 6 minutes, the hourmeter will not increase, as it counts up only in 6 minute increments. Once the engine is started, the hours will start to accumulate. The feet chipped will accumulate as long as the gate thumbswitch is activated. Distance will not accumulate when travelling and not chipping. To reset to 0, press the cal switch up or down. You must push the scroll switch up to return to each previous screen, eventually returning to the top screen.

A series of alarm functions are built into the computer. If an item sensed by the computer reaches its programmed alarm condition, the appropriate item will appear and flash on the screen, regardless of what screen is currently displayed. In addition, an output is sent to the beeper and also to the warning light mounted in the upper part of the control box. For instance, the normal use will be to have the first screen displayed (FPM & LBS/SQ. YD) - this will automatically be displayed on starting the engine. If the fuel level gets down to the alarm level (approximately 10% or 7 gallons), the word "fuel" will flash, the beeper will sound and the warning light below the steering wheel will come on. The same is true for any of the items monitored which have alarm points. The alarm points are as follows:

low oil pressure	5 PSI
high water temperature	240 F
low fuel	10%-7 Gal.
high hydraulic oil temp.	180 F.
low voltage	12 volts
high voltage	15 volts

8. Screen Scroll Switch

This switch is used to scroll the screen from the first to the fourth screen. You scroll down one screen each time you push the switch down. Upon reaching the last screen, you must push the scroll switch up to return through the screens to the first screen.

9. Speed/Direction Control Handle (Figure 6)

The control handle controls both direction (forward, neutral, reverse) and rate of speed.

Full reverse movement will give 100% of the preset speed in reverse, up to 1300 fpm. In order to back up faster, you must increase the speed setting. After backing up, you must reselect the appropriate memory button to reset the speed to your chipping speed. Full forward movement will give 100% of the selected speed set point. Speed can be slowed down at any time by pulling the handle back towards neutral and resumed by pushing the handle fully forward at any time. The control handle controls the rate of acceleration and deceleration. If the handle is moved quickly, the ChipSpreader will respond quickly. If the control handle is moved slowly, the ChipSpreader will respond slowly.

The control handle also incorporates a neutral safety start switch, automatic application of the parking brake and brake lights when placed in neutral, and activation of the backup alarm. The handle has a detent in the

neutral position and an adjustable friction drag for holding at any desired position other than neutral.

Decelerating is always accomplished by moving the handle toward neutral. Upon reaching the neutral position of the handle, the parking brake will be automatically applied, after the speed sensor reads "0" speed.

WARNING

Parking Brake Meets SAE J1472

Parking Brake may not hold on grades steeper than 15%

The control handle will operate as follows: moving the handle rearward out of the neutral position approximately 3 degrees will activate the backup alarm and release the brakes. Moving the handle further rearward will increase the reverse speed proportionate to the handle movement until full set speed is achieved with the handle in the full reverse position. Moving the handle forward out of the neutral position approximately 3 degrees will release the brakes and begin to increase the forward speed until at the full forward position of the handle the ChipSpreader will be at 100% of the set point speed and the computer will maintain the set speed. If the set speed is 200 fpm, the handle must be moved fully forward to obtain 200 fpm. If the set speed is 500 fpm, the handle must be fully forward to reach

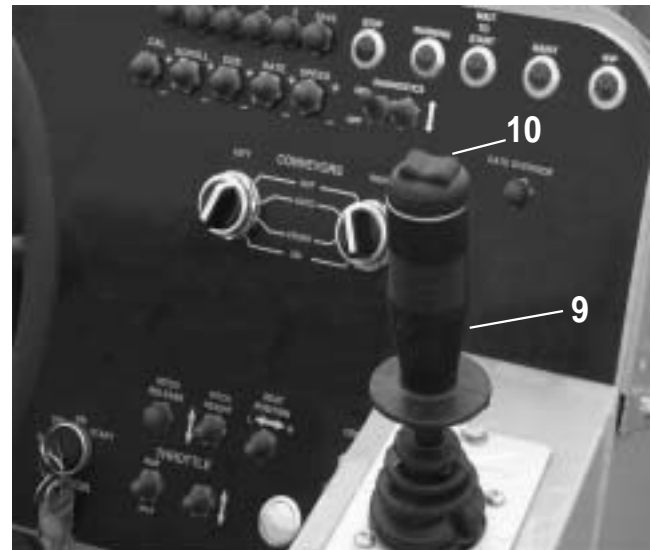

Figure 6. Speed/Direction Control Handle

9. Control Handle

10. Gate/Spread Roll Switch

500 fpm. The rate of acceleration, to the set speed, is always controlled by how fast the handle is moved from neutral to the full forward position. Adjustments to the set point speed are made using the "Speed" toggle

switch. A change in the speed setpoint may be made at any time using the “Speed” toggle switch. The speed may be decreased at any time by moving the handle rearward toward neutral without changing the set point and then be brought back up to the set point by moving the handle fully forward again. The Aggregate Application rate is automatically maintained when either of these methods is used to adjust the travel speed .

Stopping is always accomplished by returning the handle to neutral

10. Gate/Spread Roll Switch. (Figure 6)

This rocker switch (10) activates the spread roll and also the command circuit for the gates. The gate opening is set by the rate switch (5) to the desired opening. The gates are then opened or closed with the gate/spread roll switch. Depressing the left side of the switch closes the gates, while depressing the right side opens the gates. When used this way the gates will go from closed to the required opening for the speed and application rate or from the required opening to closed.

The gate opening will vary, depending on the forward speed of the ChipSpreader, to maintain the set application rate. The gate switch may be turned on at any time. If the speed is too slow for the size aggregate the computer display will read “CAUTION: Speed Too Slow” in place of the speed, but the gates will be open to an opening dependent on the speed, and as the speed increases, the gates will continue to open further to maintain the selected Application Rate . When the speed has become high enough to exceed the minimum opening for the aggregate selected, the display will return to showing the actual speed. If the speed is increased or decreased using either the “Speed Toggle Switch” or the control handle, the gates will open or close as necessary to maintain the set application rate. When the ChipSpreader has come to a halt, depress the left side of the rocker switch to close the gates. The gates will close automatically when the chipspreader’s speed is less than 30 fpm even if the switch is left on and will remain closed in neutral without being turned off, however, if they were not turned off, they will immediately begin to open whenever the forward or reverse speed exceeds 30 fpm.

11,12,13. Turn Signal Selector and Indicators. (Figure 5 & Figure 8)

Push the switch to the right to signal a right turn, and to the left to signal a left turn.



CAUTION

Turn signals are not self canceling

14. Hazard Flasher Switch (Figure 8)

Pull up for “on” and push down for “off”.

15. Headlight Switch (Figure 8)

Pull out for “on” and push in for “off”.



WARNING

Check local regulations and codes to determine the lighting and marking requirements for your usage.

16. Seat Shift Switch. (Figure 8) (Optional)

Hold the switch right or left to move the seat to the desired position. The moving seat is meant to be an operator convenience during chipping

17. Hitch Release Pushbutton (Figure 8)

Push the hitch release pushbutton to disengage the ChipSpreader from the supply truck. There must be some “slack” in the hitch (between the ChipSpreader and supply truck) in order for the latch to release. While pushing the hitch release pushbutton, one should momentarily pull the control handle rearward slightly to slow the ChipSpreader. This will cause the required “slack”. The control stick should then be pushed forward again, while still depressing the hitch release pushbutton. Once the truck has separated from the ChipSpreader, the hitch release pushbutton can be released. A second hitch release pushbutton is provided at the front operator’s controls.

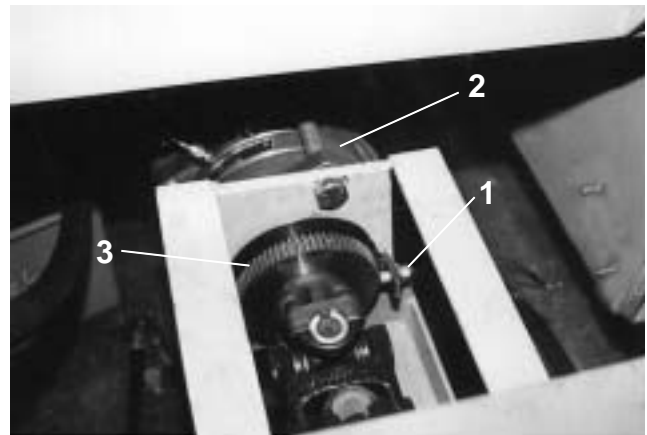

Figure 7. Ground Speed Pickup

1. Magnetic Pickup 2. Motor 3. Gear

It is possible to stop with no “slack” in the hitch (between the ChipSpreader and supply truck). If this happens, the ChipSpreader must be backed up slightly to create the necessary “slack” and then driven forward while pushing the hitch release pushbutton.

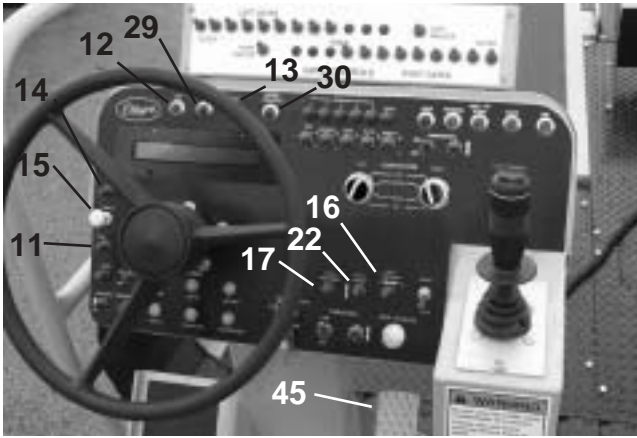

Figure 8. Control Panel

11. Turn Signal Selector	14. Hazard Flasher Switch
12. Lt Turn Signal Ind	15. Headlight Switch
13. Rt Turn Signal Ind	16. Seat Shift Switch (optional)
17. Hitch Release	22. Hitch Height
29. Warning Indicator	30. Filter Indicator
45. Brake Pedal	

In order to hook up to a supply truck, momentarily depress the hitch release pushbutton to open the hitch if it is not already open, and back into the truck. The hitch automatically closes and locks when it contacts the back of the truck.

18. Strobe/Beacon Switch (Optional)

Push the switch up to turn on the optional strobe or beacon and down to turn it off.

19. Application Rate Computer

The speed pickup (Figure 7) feeds a pulse speed signal to the computer. The gate position feedback transducer feeds a gate position signal to the computer. The computer compares the speed feedback signal to the set point and sends the appropriate signal to the pump to maintain the set speed. The computer also calculates the required gate opening for the set application rate and opens and closes the gates to maintain the application rate.

Normal spreading operation in auto speed and auto gate would be done as follows:

- Place the control handle in neutral.
- Set the desired speed using the Speed Toggle Switch (3).
- Turn the gate/spread roll switch (10) “off”.
- Set the desired application rate using the Rate Switch (5), or select the appropriate memory by pushing the memory switch up.
- Push the speed/direction handle (9) forward smoothly to the full forward position to accelerate to

the speed set point.

f) Upon reaching the starting line of spreading, depress the right side of the gate/spread roll switch (10) fully to turn the gates “on”.

g) Upon reaching the ending line, center or depress the left side of the gate/spread roll switch fully (10) to shut the gates “off”.

h) Return the control handle to neutral.

Speed changes may be made while moving by using the Speed Toggle Switch to set a new speed. The ChipSpreader will change speed to the new speed. The application rate will remain the same as long as the ChipSpreader is within the limits of gate opening for the particular aggregate selected.

If a speed is reached which requires a gate opening less than the lower limit for the aggregate selected, the message “ERROR LOW” will appear in the display, but the gate will still be open as long as the speed is above 30 fpm.

If a speed is reached which requires a gate opening greater than that available for the aggregate selected, or than the hopper has available, the message “CAUTION: Speed Too High” will appear in the display. The gates will remain open but the ChipSpreader will not be able to maintain the set application rate.

20. Right Conveyor Selector

In the bottom position, the conveyor is turned “On”.

In the next position from the bottom, power is supplied to the front operator’s “on/off” selector switch allowing the front operator to turn the conveyors “on” or “off”.

In the second position from the top, power is supplied to the auto paddle switch mounted under the triangular deflector under the conveyor hood. (See fig. 11). When this switch is tripped by material moving the paddle, the conveyor will shut off and conversely when it is untripped by a lack of material it will start the conveyor, attempting to fill the hopper.

In the upper position, the conveyor is turned “off”.

21. Left Conveyor Selector

Same operation as above except for left conveyor and left conveyor auto paddle switch.

Since both conveyors are independently controlled, it is possible to run one conveyor in one mode of control while running the other conveyor in a totally different mode if so desired.

22. Hitch Height Switch

Push up to raise the hitch, push down to lower the

hitch. When the switch is released, the cylinder will hold the hitch at a given height, about which it is free to float up and down on a spring to provide vertical articulation between the ChipSpreader the truck.

23. Gate Override Switch

Depress to momentarily fully open the hopper gate to clear a jam. Upon releasing the pushbutton, the gate will return to its original set point.

24. Memory Selector Buttons

These switches select which of the 5 preset aggregate combinations of speed, application rate, size and material is to be spread.

25. Memory Save Button

This button is used to save the preset combination once it has been set to the desired parameters. See the section on Material Calibration and saving in a preset location.

26. Calibrate Switch

The switch is used to calibrate the material before use. See the section on Material Calibration and saving in a preset location.

27. Horn

This button is used to operate the ChipSpreader's horn for signalling the truck or warning of danger.

28. Batwing Switch

This switch is used to operate the batwing hopper. Push up to raise the batwings, and down to lower.

29. Warning Light

This light will be activated whenever one of the monitored functions reaches its alarm point. As in high oil temperature, high engine coolant temperature, low engine oil pressure, low voltage, and low fuel. The function which has reached its alarm point will be described in the computer's digital display.

30. Filter Indicator

This light indicates that the charge pressure filter is clogged when lit.

31. Traction Control Switch

This switch transfers torque to the front axle. The joystick must be in neutral to engage this switch. If a rear wheel spins, position the joystick in neutral and press and hold the traction control switch to the on position. Move the joystick out of neutral while holding the switch and drive the chipspreader into an area with better traction. The chipspreader speed is limited to 200 fpm while the switch is engaged.

32. Throttle Run/Idle Switch

The engine should be started with the switch in the idle position. The engine will run at low idle when the switch is in this position. When the switch is in the run position, the engine will run at high idle. The hydrostatic system is designed to run at high idle, therefore the switch should be in this position to perform any work.

33. Throttle Increase/Decrease Switch

Press the switch up to increase the engine RPM and down to decrease the engine RPM. This switch works only when the Run/Idle switch is in the run position.

34. Auxiliary 12 Volt Power

A "Cigarette Lighter" style 12 volt power supply. This supply is only on when the ignition switch is in the on position.

35. Engine Diagnostics On/Off Switch

With the ignition switch in the on position (engine not running) position the diagnostic switch in the on position to access the engine fault codes. The stop light (Ref 37) will flash a series of times corresponding to a particular fault code. The warning light (Ref 38) will light when the code is finished.

36. Engine Diagnostics Increase/Decrease Switch

If more than one fault code is present, press this switch to scroll through the active fault codes. This switch is only active when the on/off switch (Ref 35) is in the on position.

37. Engine Diagnostics Stop Light

When the stop light is lit, shut down the engine. Access the fault code and call your Cummins dealer.

38. Engine Diagnostics Warning Light

The warning light indicates something is wrong with the engine and should be looked into soon.

39. Engine Diagnostics Wait To Start Light

The engine is equipped with grid heaters for cold starts. In cold temperatures (approximately 46°F), the grid heaters will come on when the ignition switch is in the on position. Do not start the engine until this light has gone out.

40. Engine Diagnostics Maintenance Light

The maintenance light will come on when routine engine maintenance is due. Check the Cummins engine manual for routine scheduled maintenance.

41. Engine Diagnostics Water In Fuel Light

The water in fuel light will come on whenever the fuel filter senses water in the fuel.

42. Individual Gates Master Switch

This switch connects the selected individual gates to the Thumb Switch on the top of the control stick so that the selected gates will open when the Thumb Switch is turned on. A more detailed description of how the gate operates is located in the section on the Individual Gates.

43. Left Hopper Gate Selector Switches

These switches select which gates on the left hopper will be opened when the Thumb Switch is turned on. Once the hopper is spreading, these switches are used to control individual gates on the left hopper, turning them on or off as the spread requires. A more detailed description of how the gate operates is located in the section on the Individual Gates.

44. Right Hopper Gate Selector Switches

These switches select which gates on the right hopper will be opened when the Thumb Switch is turned on. Once the hopper is spreading, these switches are used to control individual gates on the right hopper, turning them on or off as the spread requires. A more detailed description of how the gate operates is located in the section on the Individual Gates.

45. Brake Pedal (Figure 8)

The brake pedal can be used to assist the hydrostatic braking. For instance, the parking brake is applied when the computer sees the chispreader is stopped. On a grade, the chispreader may roll back, since it did not come to a complete stop and apply the parking brake. The foot brake will hold the chispreader on the grade until the parking brake is set.

When the chispreader is in motion and the brake pedal is applied, a pressure switch in the brake line sends a 12 volt signal to the computer, which destrokes the pump. The chispreader will decelerate as long as the brake pedal is applied until it comes to a stop, regardless of the joystick position. To resume operation, the joystick must be returned to center. If the brake pedal is released during deceleration, the speed at that instant will become the new speed set point. For example, if the chispreader is traveling at 1000 FPM and the brake pedal is applied, the chispreader will begin to decelerate. If the brake pedal is then released at 500 FPM, this will be the new speed set point. When the joystick is returned to center, the speed set point will return back to the original 1000 FPM.

50. Emergency Stop Switch

The emergency stop switch will bring the chispreader to a controlled stop when activated, regardless of the joystick position. The switch stops the engine while maintaining electrical power, insuring a predictable stop. To restart the engine, the switch must be reset by turning the knob clockwise. The foot pedal service brake is active with the emergency stop switch and can be used to bring the chispreader to a quicker stop.

50. Computer Reset Switch



WARNING

Do not reset computer while chispreader is in motion. Violent stop will occur which could cause a fall resulting in injury or death.

When activated simultaneously, the computer reset switches will reset the computer. Activating a single switch will have no effect on the computer. In the event of a low voltage alarm, the computer can be reset without having to restart the engine. The park/drive switch must be placed in the park position while resetting the computer. The chispreader will not respond to the joystick until the park/drive switch has been placed in the park position.

The following items are located at the front operator's station on top of the right conveyor.

46. Left Conveyor Switch

When the driver has selected "front" on the left conveyor selector switch (21) this switch will turn the left conveyor "on" or "off".

47. Right Conveyor Switch

When the driver has selected "front" on the right conveyor selector switch (20) this switch will turn the right conveyor "on" or "off".

48. Hitch Release Pushbutton

Push the hitch release pushbutton to disengage the supply truck from the ChipSpreader. (See item 17 of main control panel description)

49. Gate Override Switch

Depress to momentarily fully open the hopper gate to clear a jam. Upon releasing the pushbutton, the gate will return to its original set point.

Operation

WARNING

Unsafe operation of equipment may cause injury. Read, understand and follow the manuals when operating or performing maintenance.

WARNING

Never put hands in between gate and spread roll or gate and rear of hopper. The gate could move at any time and cause severe injury.

WARNING

Do not travel with the seat unlatched. Seat movement could occur causing disorientation and possible loss of control.

Remain clear of all moving parts.

CAUTION

Before operating the ChipSpreader, make an inspection of the machine to be sure that the machine is in a safe condition to operate.

WARNING

Always use steps, platforms and handrails provided.

Always have shields, covers and guards in place when operating.

Make certain everyone is clear of machine before starting or operating the machine.

Since all functions except power steering and brakes are electrically controlled, turning the ignition key to "off" results in an emergency stop.

Keep loose clothing away from conveyor area when operating the conveyors.

CAUTION

Always install locking control box cover and chock wheels when leaving machine unattended as protection against vandalism and accidental movement.

IMPORTANT

Do not tow the ChipSpreader before reading the towing instructions contained in this manual. Improper towing may damage the hydraulic motors.

WARNING

Unsafe operation of equipment may cause injury. Read, understand and follow the manuals when operating or performing maintenance

Never put hands in between gate and spread roll or gate and rear of hopper to clear obstruction. The gate could move at any time and cause severe injury.

Remain clear of all moving parts.

Should a piece of foreign material become lodged in the gates, push the gate override switch to open the gate above the set point to allow the piece to pass. Releasing the override will return the gates to the previously set position.

Adjust ChipSpreader hitch height as necessary to accommodate different individual trucks.

Operate the conveyor belt switches so as to maintain an even distribution of aggregate in the front hopper.

Conveyor flow deflectors should be used to achieve the desired material distribution in the front hopper (Fig.9).

Conveyor hoods should be used to adjust the distribution to the front hopper, primarily to control the amount of material in the front hopper in the area in front of the conveyor. The amount of material in front of the conveyor will affect when the auto conveyor switch is tripped to shut off the conveyor. Generally,

the larger the stone, the further forward the hood should be positioned. Approximately 1 1/2" gap is a good starting point for 3/8" to 1/2" chips.

The machine is equipped with conveyor belt speed controls. The rear conveyor gates should be set to deliver as much material as possible into the conveyor without spillage and then the conveyor speed should be adjusted to deliver slightly more aggregate to the front hopper than the amount being spread. When properly adjusted, the conveyors should run approximately 80% of the time with the hopper spreading full width and the ChipSpreader traveling at maximum speed for the particular job.

The operator may wish to disengage the front hopper agitator while spreading clean dry aggregate. This operation is performed by removing the agitator disconnect bolt. This will prevent unnecessary wearing of the agitator.

Automatic Conveyor Control

When the conveyor selector switch (Fig 5, ref 20 & 21) is in the auto position, power is supplied to the auto paddle switch mounted below and along the inboard side of the conveyor hood. When this switch is tripped by material moving the paddle, the conveyor will shut "off" and conversely when it is untripped by lack of material it will start the conveyor attempting to fill the hopper. (Fig. 11)

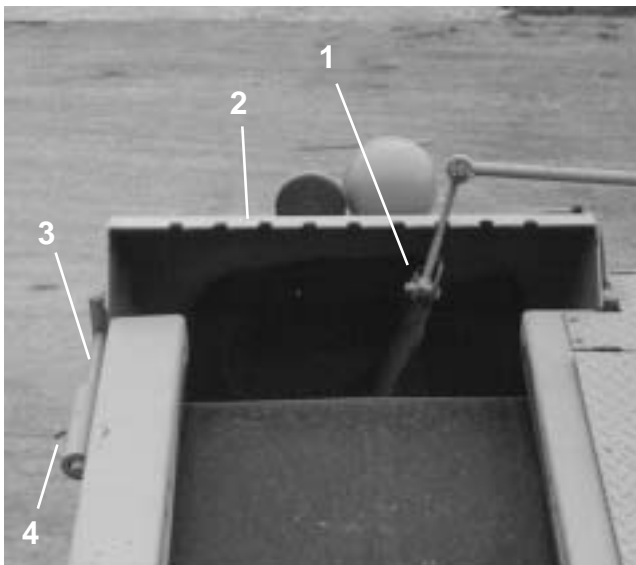

Figure 9. Conveyor Hood and Flow Deflector

- 1. Conveyor Flow Deflector
- 2. Conveyor Hood
- 3. Hood Adjustment
- 4. Hood Adjustment Set Screw

Belt Speed Controls (Figure 12)

This feature allows the operator located on the right catwalk to vary the speed of each conveyor independently to provide a uniform distribution of material to the front hopper. Valves for this operation are incorporated in the integrated circuit block on top of the right conveyor, outboard of each conveyor's solenoid valve. Each valve has an adjustment knob and a locking ring.

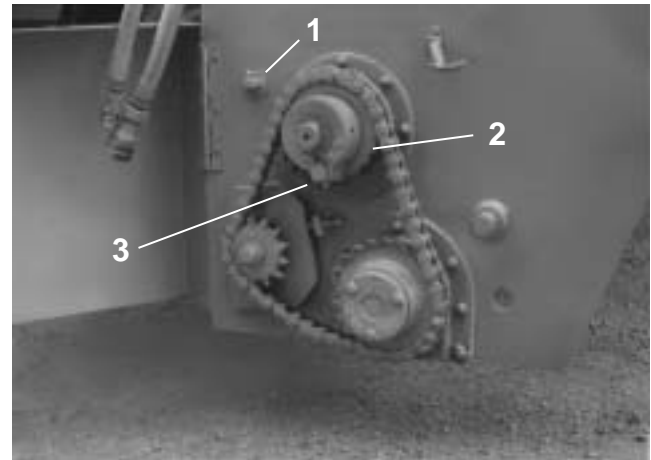

Figure 10. Hopper Chain Drive

- 1. Drive Bolt Holder
- 2. Agitator Drive Sprocket
- 3. Sprocket Drive Bolt

With the knob screwed fully out, the conveyor will run at its highest speed. Screwing the knob clockwise to its full in position will slow the conveyor down. The knob may be positioned anywhere in between and locked at the desired speed with the lock ring.

This feature is particularly useful in doing shoulder work or in operations requiring less than full hopper width. It is also useful in trying to smooth out delivery of material to match the rate being spread. (Fig.12) When properly adjusted, the conveyors should run approximately 80% of the time with the hopper spreading full width and the ChipSpreader traveling at maximum speed for the particular job.

CAUTION
<p>Keep loose clothing away from conveyor area when operating conveyors</p>

Backup Alarm

The electric backup alarm is automatically actuated when the speed/direction control handle (Fig. 6) is pulled to the rear of neutral.

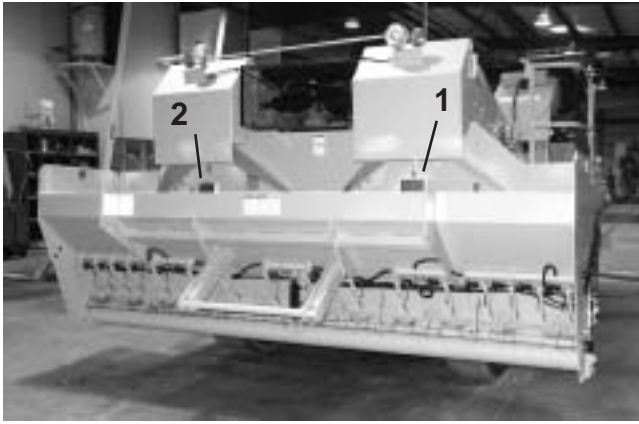



Figure 11. Material Level Paddle

- 1. Left Paddle
- 2. Right Paddle

Optional Equipment

 WARNING
<p>Unsafe operation of equipment may cause injury. Read, understand and follow manuals when operating or performing maintenance.</p>

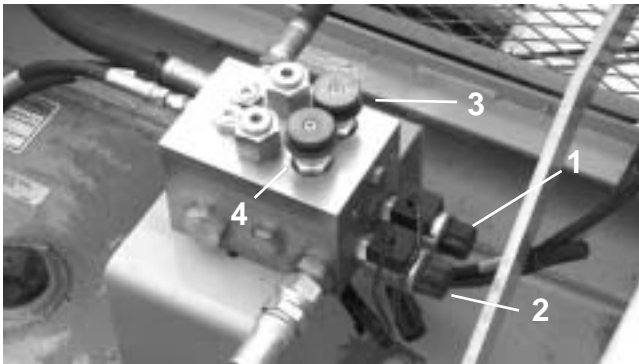

Figure 12. Belt Speed Controls

- 1. Rt Conveyor Solenoid Valve
- 2. Lt Conveyor Solenoid Valve
- 3. Rt Speed Control Valve
- 4. Lt Speed Control Valve

Hydraulic Powered Seat Assembly

A hydraulically powered seat positioner is operated by a spring centered toggle switch (Fig. 16). The seat may be positioned wherever it is desired for operation.

Extra Agitator

When sand or other small aggregate is being spread, an optional second agitator may be placed in the hopper so as to greatly reduce the possibility of bridging. This agitator should be disengaged normally and only used when bridging has been experienced.

Segregation Screen

When the aggregate is not of a uniform size, the optional front hopper segregation screen may be used to place larger chips on the asphalt ahead of smaller chips and fines. This helps prevent the smaller chips and fines from blotting out the larger material (Figure 13).

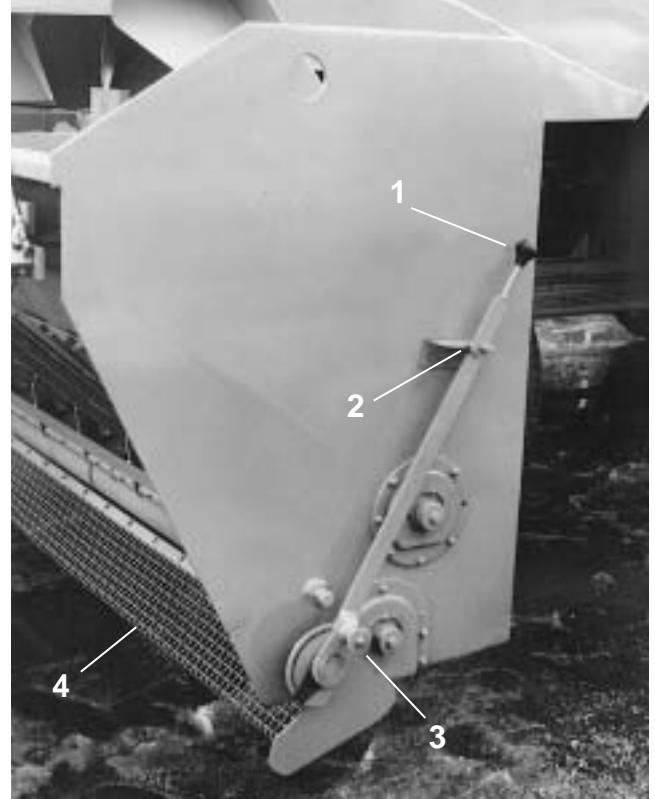

Figure 13. Segregation Screen

- 1. Handle
- 2. Lock
- 3. Latch
- 4. Segregator Screen

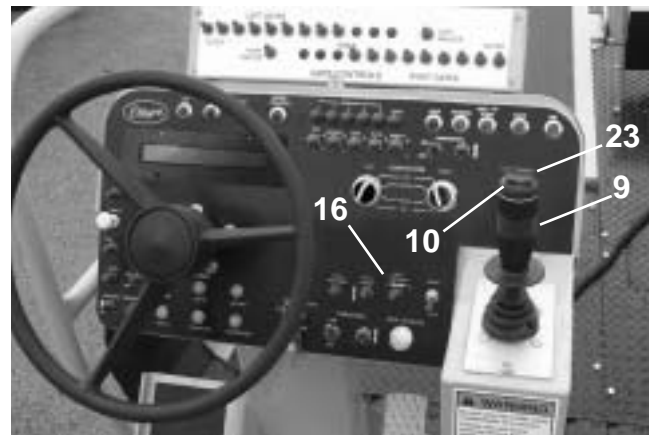

Figure 14. Driver Control Station

- 9. Control Handle
- 10. Gate Thumb Switch
- 16. Seat Position Switch
- 23. Gate Override Push Button

Appendix A

Maintenance Adjustments

WARNING

When two people are required to perform adjustments or maintenance operations or two people are simultaneously performing different operations, the work must be coordinated between the two people to avoid possible injuries.

WARNING

When two people are performing maintenance adjustments, do not start engine without assuring that the other person is clear of moving parts and out from under the machine. Be sure that the mode selector is in park and the control stick is in neutral before attempting to start engine.

Hopper Spread Roll Wear Plate Adjustment

Turn spread roll and conveyors “off”.

1. Loosen all spread roll wear plate hold down bolts and adjust the wear plate until a nominal 1/16" clearance exists between the wear plate and the spread roll for the entire hopper width.

2. Re tighten all the hold down bolts.

3. When one side of a plate has been worn away it is possible to turn the plate over and use the opposite side.

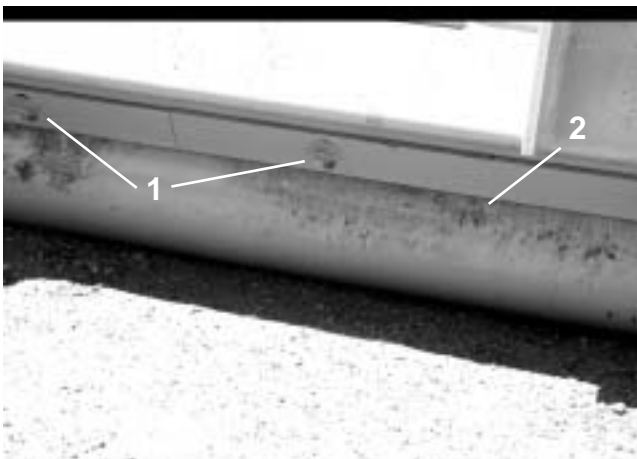

Figure 15. Spread Roll Wear Plate

1. Hold Down Bolts 2. Spread Roll Wear Plate

Hopper Gate Wear Plate Adjustment

Turn spread roll and conveyors “off”.

1. Loosen wear plate hold down bolts and extend the plate 1/32" past the gate edge along the entire gate width.

2. Tighten hold down bolts.

3. As plate wear occurs, additional adjustment will be necessary.

4. When one side of a plate has been worn away it is possible to turn the plate over and use the opposite side.

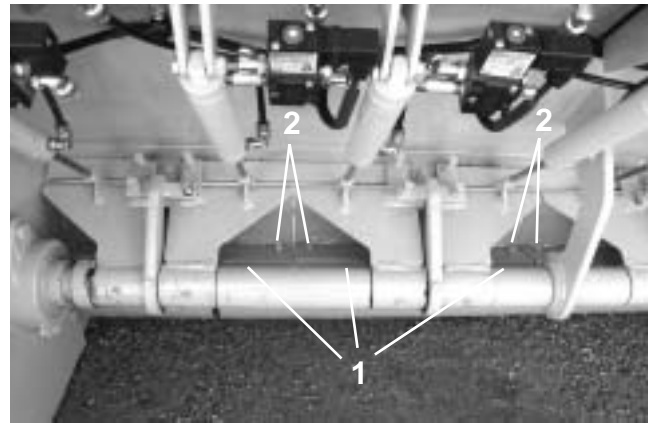

Figure 16. Gate Wear Plate

1. Gate Wear Plate (Below) 2. Hold Down Bolts (Below)

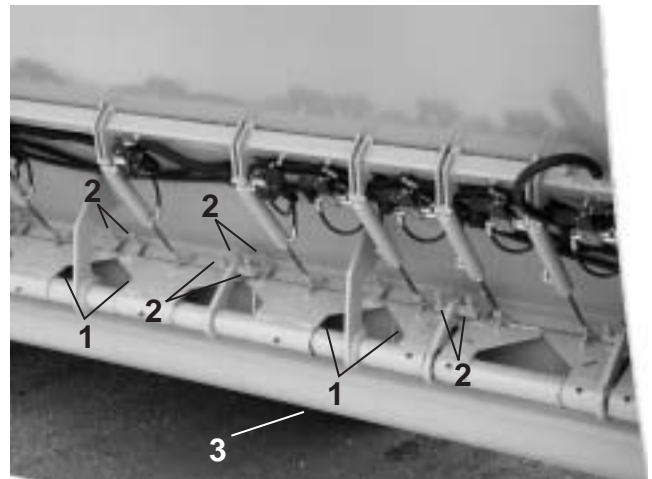

Figure 17. Hopper Gates

1. Gates 2. Adjustments Bolts 3. Spread Roll

Conveyor Belt Adjustment

1. If the conveyor belt tends to move towards one side of the conveyor, tighten tail pulley adjustment on that side until the belt is running in the center.

2. Should it be impossible to obtain centered belt operation by adjusting the tail pulley (Fig. 18) it will then be necessary to adjust the head pulley as outlined below. (Fig. 19)

For the right hand conveyor:

- a) Loosen the four bolts holding the left hand side head pulley bearing.
- b) Loosen adjusting bolt jam nuts.
- c) Start conveyor at this time.

⚠ WARNING
Conveyor must be running during this procedure. To avoid personal injury, be sure to remain clear of moving belt.

⚠ WARNING
Remain clear of moving parts.

d) If belt runs to the right hand side of the conveyor, loosen the adjusting screws until the belt is centered on the head pulley.

e) If belt runs to the left hand side of the conveyor, tighten the adjusting screws until the belt is centered on the head pulley.

- f) Re tighten adjusting screw jam nuts.
- g) Stop the conveyor belt.
- h) Tighten head pulley bearing bolts.

For left hand conveyor:

- a) Loosen the four bolts holding the right hand side head pulley bearing.
- b) Loosen the adjusting bolt jam nuts.
- c) Start conveyor at the time.

⚠ WARNING
Remain clear of all moving parts.

d) If belt runs to the right side of the conveyor, tighten the adjusting screws until the belt is centered on the head pulley.

e) If belt runs to the left side of the conveyor, loosen the adjusting screws until the belt is centered on the head pulley.

- f) Re tighten adjusting screw jam nuts.
- g) Stop the conveyor belt.
- h) Tighten head pulley bearing bolts.

NOTE: Only a small amount of head pulley adjustment should be necessary to center conveyor belts.

3. Conveyor belts should be sufficiently tight to prevent head pulley slippage when the belts are loaded and operating at full governed speed. It should be noted, however, that excessive belt tightness will result in shortened belt and pulley bearing life. It may be necessary to tighten the belts several times during the first few weeks of operation until most of the initial belt stretch has been removed. When doing so it is necessary to tighten each side equally to keep the belt running centered.



Figure 18. Conveyor Tail Pulley

1. Conveyor Belt Tail Pulley Adjustment Bolt (4 Places)

⚠ WARNING
The fuel tank is part of the crosswalk. Do not drill or weld in this area.

⚠ CAUTION
To avoid potential damage to electrical components, disconnect batteries before welding

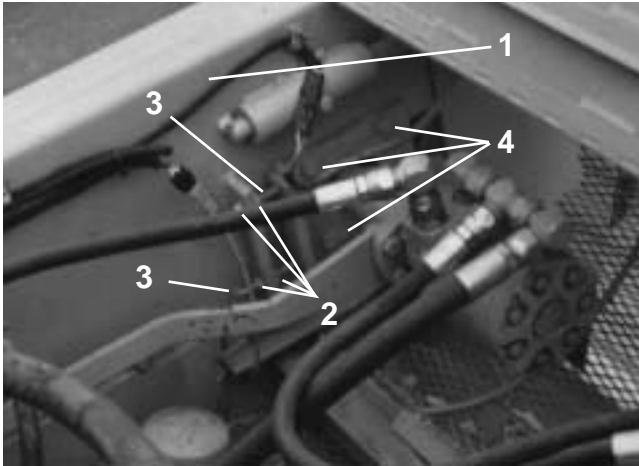

Figure 19. Conveyor Head Pulley Adjustment

- | | |
|--------------------|-------------------------------|
| 1. Left Conveyor | 4. Bearing Bolts |
| 2. Jam Nut | 5. Hood Adjustment |
| 3. Adjusting Screw | 6. Hood Adjustment Set Screws |



IMPORTANT

Do not tow the chipspreader before reading the towing instructions contained in this manual. Improper towing may damage the hydraulic motors and rear brakes.

Towing Instructions

Disconnect driveline assembly at front axle. On a 4WD machine, also disconnect the driveline on the rear axle

Appendix B

Computer Setup

Computer Set Up

The computer must be set up and the various sensors calibrated for the particular ChipSpreader that the computer is installed in. This is normally done at the factory, and the settings are retained in the computer's non volatile memory. Normally an entire set up does not have to be done in the field, but if a joystick or a gate transducer is replaced, that particular item would have to be re calibrated. In the case of a gate transducer, it should be mechanically set using the procedure described under "Hopper Gate Transducer Adjustment" before re calibrating the computer. In order to do that, you must enter the set up screens and follow through the various screen as described below. If an item is already properly set, you can just scroll by it to the next item, until you get to the one that needs to be re-calibrated. If any one item is changed, you must save it using the procedure described at the end of the various screens.

Set Up Screens

The following screens are entered by holding the cal switch either up or down while turning the ignition key on.

IMPORTANT: The setup of the computer should be performed with the ignition key on, but the engine not running, except for calibrating the gates and the speed.

	CAUTION
<p>Always place the mode selector switch in the "park" position when the chipspreader is stopped to avoid accidental movement of the machine.</p>	

These screens are used to configure the computer to the particular ChipSpreader and to calibrate the speed pickup, control stick, gates, and application rate. The first screen will appear when the ignition key is released from the start position.

SETUP: FIRMWARE

Version 2.xx

This screen shows the version of firmware which is loaded in the machine. (version 2.60 for example)

Push the "scroll" switch down to move to the next screen.

SETUP: CONTRAST

Use the "cal switch to adjust the screen contrast up or down. Push the "scroll" switch down to move to the next screen.

SETUP: ENGINE CUMMINS

This screen shows which engine is in the machine and sets the tach input for that manufacturers engine. Use the "cal" switch to toggle between Cummins and Caterpillar engines. Push the "scroll" switch down to move to the next screen.

SETUP: DRIVE 4 WHEEL

This screen is used to set the type of drive in the machine. Either 2 wheel or 4 wheel drive. Use the "cal" switch to toggle between 2 and 4 wheel drive. Push the "scroll" switch down to move to the next screen.

SETUP: MOTOR SIZE 160 CC

This screen is used to set the motor displacement. Use the "cal" switch to set the motor displacement to 160 CC. When this has been properly set, push the "scroll" switch down to move to the next screen.

SETUP: HOPPER FIXED

This screen is used to set the type of hopper installed on the machine. Use the "cal" switch to toggle between fixed and variable hoppers. When this set for your machine, push the "scroll" switch down to move to the next screen.

SETUP: UNITS ENGLISH

This screen is used to set the display units to either english or metric. Use the "cal" switch to toggle be-

tween english and metric units. When this set for your machine, push the “scroll” switch down to move to the next screen.

SETUP: JOYSTICK

Actual 0.0%

This screen is the entry screen for calibrating the joystick. It should say 0.0% with the stick in neutral. If the stick is pushed full forward, the reading should change to 100% and if it pulled fully back into reverse, the reading should change to -100%. If it does not at any of these positions, place the stick in neutral. Be sure it is in neutral and then push the “cal” switch. **Once you have pushed the “cal” switch you must complete the sequence or you will have lost the existing calibration of the joystick.** When you push the “cal” switch, the screen will change to

SETUP: JOYSTICK

Neutral 0.0 volts

Push the “cal” switch to calibrate the neutral position. The display will change to

SETUP: JOYSTICK

forward 0.0 volts

Push the stick full forward, the reading should change to approximately 4.8 or 4.9 volts. When you have the stick fully forward, push the “cal” switch to calibrate the full forward position of the control stick. The display will change to

SETUP: JOYSTICK

reverse 0.0 volts

Pull the stick to the full reverse position, the reading should change to approximately 4.8 or 4.9 volts. When you have the stick fully rearward, push the “cal” switch to calibrate the full reverse position of the control stick. The display will change to

SETUP: JOYSTICK

Actual 0.0%

When you have finished calibrating the joystick, push the “scroll” switch to change to the next screen.

SETUP: THRESHOLDS

Forward: 0.450 amps

This screen is used to set the threshold current to the forward solenoid on the hydrostatic pump. This value should be set to 0.450 amps, using the “cal” switch. When it is set to this value, push the “scroll” switch to move to the next screen.

SETUP: THRESHOLDS

Reverse: 0.350 amps

This screen is used to set the threshold current to the reverse solenoid on the hydrostatic pump. This value should be set to 0.350 amps, using the “cal” switch. When it is set to this value, push the “scroll” switch to move to the next screen.

SETUP: RIGHT NULL

Actual: 0.00 inches

This screen is not used for a fixed hopper. Push the “scroll” switch to move to the next screen.

SETUP: RIGHT SCALE

Actual: 0.00 inches

This screen is not used for a fixed hopper. Push the “scroll” switch to move to the next screen.

SETUP: LEFT NULL

Actual: 0.00 inches

This screen is used to set the actual closed position of the gates. Be sure that the gates are actually closed. This number should read 0.00 inches, if this number is not 0.00, set it to 0.00 using the “cal” switch. When it is set to this value, push the “scroll” switch to move to the next screen.

For a fixed hopper, the computer uses the left gate settings.

SETUP: LEFT SCALE

Actual: 0.00 inches

This screen is used to set the actual open position of the left gate. The number will read 0.0 inches until the left gate override is actuated. While holding the left gate override the number should read 4.00 inches. If it does not read 4.00, first visually verify the gate is actually fully open. After verification, while holding the left gate override press the CAL switch to set the value to 4.00 inches. When the left gate override is released the number on the screen should go back to 0.00.



WARNING

Never put hands in between gate and spread roll or gate and rear of hopper to clear obstruction. The gate could move at any time and cause severe injury.

SETUP: Front Motor

0 fpm 0.400 amp

This screen is used to set the threshold current to the front motor. The threshold current normally does not need to be changed. It only might need to be changed if the ChipSpreader is to be operated at extremely slow speeds -well under 100 fpm. Operate the chipspreader at 300 fpm. While the chipspreader is running at 300 fpm, increase the threshold current until a change in speed is felt, and then back it down until there is no speed change. The normal threshold current setting from the factory is 0.400 amps. When it is set to this value, push the “scroll” switch to move to the next screen.

SETUP: Rear Motor

0 fpm 0.400 amp

This screen is used to set the threshold current to the rear motor of a 4WD ChipSpreader. The threshold current normally does not need to be changed. It only might need to be changed if the ChipSpreader is to be operated at extremely slow speed -well under 100 fpm. Operate the chipspreader at 300 fpm. While the chipspreader is running at 300 fpm, increase the threshold current until a change in speed is felt, and then back it down until there is no speed change. The normal threshold current setting from the factory is 0.400 amps. When it is set to this value, push the “scroll” switch to move to the next screen.

The calibration done in these setup screens is to adjust the open and close thresholds on the proportional valves controlling the gate cylinder. These thresholds determine the speed at which the gates open and close.

The right gate is not used on a fixed hopper. Push the scroll switch down to scroll past the right gate setup screens.

SETUP: RIGHT OPEN

1.200 amps

SETUP: RIGHT CLOSE

1.200 amps

SETUP: LEFT OPEN

1.200 amps

Use the “cal” switch to adjust the current up or down to increase or decrease the speed of the left gate opening time.

SETUP: LEFT CLOSE

1.200 amps

Use the “cal” switch to adjust the current up or down to increase or decrease the speed of the left gate closing time.

SETUP: GATE OPEN HOLD

DISTANCE: 0.0 inches

This screen is used to set the delay of the right gate on a variable hopper. This value should be set to 0.0 except on special units. If the number is changed to 10.0, for example, the computer would wait until the chipspreader travels 10 inches before the right gate would begin to open. The left gate is not affected by changing this number.

SETUP: GATE SHUT HOLD

DISTANCE: 0.0 inches

This screen is used to set the delay of the right gate on a variable hopper. This value should be set to 0.0 except on special units. If the number is changed to 10.0, for example, the computer would wait until the chipspreader travels 10 inches before the right gate would begin to close. The left gate is not affected by changing this number.

SETUP: SAVE AND EXIT

Press Save to Exit

Press the “Save” button to save any changes that were made, or press the “Scroll” switch down to exit without saving.

Appendix C

Computer Service Screens

Service Screens

The service screens are entered by holding the “scroll” switch either up or down while turning the ignition key on. The first four screens are the same as the “Operator Screens” described under “OPERATOR SCREENS” but will be repeated here.

CAUTION: When in the service screens, all interlocks are disabled and it is possible to open the gates in the manual mode while standing still.

20.0	3/8	400
lb/yd²	Chip	fpm

This screen shows the application rate set point, aggregate preset and the speed set point when standing still.

This is the screen that will come up when the ignition is turned on and the engine is started, while holding the “scroll” switch either up or down. To move to the next screen, push the scroll switch down.

100°F	60 PSI	15%
WATER	OIL	FUEL

This screen shows the engine coolant temperature on the left, the engine oil pressure in the center, and the fuel remaining in the fuel tank on the right. To move to the next screen, push the scroll switch down.

100°F	2200 RPM	13.8 V
HYD OIL	ENGINE	BATTERY

This screen shows the hydraulic oil temperature on the left, the engine rpm in the center, and the system voltage on the right side. To move to the next screen, push the scroll switch down.

120.8	7550 FT
ENGINE	CHIPPED

This screen shows the hours on the machine on the left side, and the feet chipped on the right side. To move

to the next screen, push the scroll switch down to move to the first real service screen

SERVICE: RIGHT NULL
Actual: 0.0 inches

This screen shows the actual position of the right gate. Push the scroll switch down to move to the next screen.

SERVICE: LEFT NULL
Actual: 0.0 inches

This screen shows the actual position of the left gate. Push the scroll switch down to move to the next screen.

SERVICE: Aggre. Last
Status: De-activated

This screen shows the position of the “Size” switch. Push the “Size” switch up and the display should change to Activated until the switch is released. Push the scroll switch down to move to the next screen.

SERVICE: Aggre. Next
Status: De-activated

This screen shows the position of the “Size” switch. Push the “Size” switch down and the display should change to Activated until the switch is released. Push the scroll switch down to move to the next screen.

SERVICE: Appl Rate-
Status: De-activated

This screen shows the position of the “Rate” switch. Push the “Rate” switch down and the display should change to Activated until the switch is released. Push the scroll switch down to move to the next screen.

SERVICE: Appl Rate+
Status: De-activated

This screen shows the position of the “Rate” switch. Push the “Rate” switch up and the display should change to Activated until the switch is released. Push the scroll switch down to move to the next screen.

SERVICE: Cal Rate-
Status: De-activated

This screen shows the position of the “Cal” switch. Push the “Cal” switch down and the display should change to Activated until the switch is released. Push the scroll switch down to move to the next screen.

SERVICE: Cal Rate+
Status: De-activated

This screen shows the position of the “Cal” switch. Push the “Cal” switch up and the display should change to Activated until the switch is released. Push the scroll switch down to move to the next screen.

Be sure the “Park /Drive” Mode Switch is in the park position before performing the next sequence of checks.

SERVICE: L.GATE SEL
Status: De-activated

This screen is used to check the operation of the various switches for the gate circuit. Depress the right side of the “Thumb” switch and push the joystick out of neutral. The display should change to Activated. Check that it is deactivated with each of the following switches. Put the joystick in neutral. It should become deactivated. Push the joystick out of neutral, it should become activated again. With the joystick still out of neutral, center the “Thumb” switch and it should become deactivated. Turn the “Thumb” switch back on again. Push the scroll switch down to move to the next screen.

SERVICE: L.GATE OVER
Status: De-activated

This screen shows the position of the “Gate Override” switch. Push the gate override button down and the display should change to activated as long as the

button is held down and return to deactivated when the button is released. Push the scroll switch down to move to the next screen.

SERVICE: R.GATE SEL
Status: De-activated

This screen is not used for a fixed hopper. Push the scroll switch down to move to the next screen.

SERVICE: R.GATE OVER
Status: De-activated

This screen is not used for a fixed hopper. Push the scroll switch down to move to the next screen.

SERVICE: Save
Status: De-activated

This screen shows the position of the “Save” Button. Push the “Save” button down and the display should change to Activated as long as the button is held down. Push the scroll switch down to move to the next screen.

SERVICE: Setup #1
Status: De-activated

This screen shows the position of the “Memory 1” Button. Push the “Memory 1” button down and the display should change to Activated as long as the button is held down. Push the scroll switch down to move to the next screen.

SERVICE: Setup #2
Status: De-activated

This screen shows the position of the “Memory 2” Button. Push the “Memory 2” button down and the display should change to Activated as long as the button is held down. Push the scroll switch down to move to the next screen.

SERVICE: Setup #3
Status: De-activated

This screen shows the position of the “Memory 3” Button. Push the “Memory 3” button down and the display should change to Activated as long as the button is held down. Push the scroll switch down to move to the next screen.

SERVICE: Setup #4

Status: De-activated

This screen shows the position of the “Memory 4” Button. Push the “Memory 2” button down and the display should change to Activated as long as the button is held down. Push the scroll switch down to move to the next screen.

SERVICE: Setup #5

Status: De-activated

This screen shows the position of the “Memory 5” Button. Push the “Memory 5” button down and the display should change to Activated as long as the button is held down. Push the scroll switch down to move to the next screen.

SERVICE: VEH. SPEED-

Status: De-activated

This screen shows the position of the “Speed” Switch. Push the “Speed” switch down and the display should change to Activated as long as the switch is held down. Push the scroll switch down to move to the next screen.

SERVICE: VEH. SPEED+

Status: De-activated

This screen shows the position of the “Speed” Switch. Push the “Speed” switch up and the display should change to Activated as long as the switch is held up. Push the scroll switch down to move to the next screen.

SERVICE: RELEASE

Status: De-activated

This screen shows the position of the “Brake Re-

lease” Switch. With the “Park/Drive” Mode selector in the park position and the engine not running, push the control stick out of neutral. The display should change to activated until the control stick is returned to neutral. Push the scroll switch down to move to the next screen.

SERVICE: BATTERY

Status: 12.3 volts

This screen shows the condition of the battery and charging system. With the engine not running the battery voltage will be displayed. When the engine is running, the display will show the output voltage of the alternator. Push the scroll switch down to move to the next screen.

SERVICE: OIL PRESSURE

Status: 4.80 volts

This screen shows the voltage being measured in the oil pressure sender circuit. Push the scroll switch down to move to the next screen.

SERVICE: WATER TEMP

Status: 4.80 volts

This screen shows the voltage being measured in the water temperature sender circuit. Push the scroll switch down to move to the next screen.

SERVICE: Engine Speed

Status: 0 Hertz

This screen shows the frequency being measured in the engine tachometer circuit. Push the scroll switch down to move to the next screen.

SERVICE: Fuel Level

Status: 2.80 Volts

This screen shows the voltage being measured in the fuel level circuit. Push the scroll switch down to move to the next screen.

SERVICE: Hyd Oil Temp

Status: 8.82 Volts

This screen shows the voltage being measured in the hydraulic oil temperature circuit. Push the scroll switch down to move to the next screen.

SERVICE: Front Speed

Status: 0 Hertz

This screen shows the frequency being measured in the front motor speed feedback circuit. Push the scroll switch down to move to the next screen.

SERVICE: Rear Speed

Status: 0 Hertz

This screen shows the frequency being measured in the rear motor speed feedback circuit. It is normally not used. Push the scroll switch down to move to the next screen.

SERVICE: Left Gate

Status: 0.00 Volts

This screen shows the voltage being measured in the gate feedback circuit. Push the scroll switch down to move to the next screen.

SERVICE: Right Gate

Status: 0.00 Volts

This screen is not used for a fixed hopper. Push the scroll switch down to move to the next screen.

SERVICE: Joystick

Status: 0.00 Volts

This screen shows the voltage being measured in the joystick circuit. 0.0 volts is the neutral position with +4.8 volts and -4.8 volts being the full forward and full reverse positions respectively. Push the scroll switch down to move to the next screen.

SERVICE: Forward

Status: 0.00 Amps

This screen shows the current to the forward solenoid of the pump. Push the scroll switch down to move to the next screen.

SERVICE: Reverse

Status: 0.00 Amps

This screen shows the current to the reverse solenoid of the pump. Push the scroll switch down to move to the next screen.

SERVICE: Front Motor

Status: 0.00 Amps

This screen shows the current to the front motor in either a 2WD or a 4WD machine. Push the scroll switch down to move to the next screen.

SERVICE: Rear Motor

Status: 0.00 Amps

This screen shows the current to the rear motor in a 4WD machine. Push the scroll switch down to move to the next screen.

SERVICE: Left Close

Status: 0.00 Amps

This screen shows the current to the gate closing solenoid. Push the scroll switch down to move to the next screen.

SERVICE: Left Open

Status: 0.00 Amps

This screen shows the current to the gate open solenoid. Push the scroll switch down to move to the next screen.

SERVICE: Right Close

Status: 0.00 Amps

This screen is not used for a fixed hopper. Push the scroll switch down to move to the next screen.

SERVICE: Right Open

Status: 0.00 Amps

This screen is not used for a fixed hopper. Push the scroll switch down to move to the next screen.

2 hrs

0 ft

ENGINE

CHIPPED

From this screen, scrolling down will bring you back into the service screens, while scrolling up 3 times will take you back to the top operating screen.

Systems Startup And Adjustments

Hydrostatic System Startup

After any work has been done on the hydrostatic ground drive system which involved opening up the circuit in any way, the following startup procedure should be used.

1. Jack the machine up and securely support on stands with all four wheels off the ground.
2. Disconnect the 23 pin round connector at the engine, so that the engine can only be cranked and cannot be started. (Fig. 21)
3. Disconnect the forward and reverse connectors at the pump stroker.

WARNING

Be certain that machine is securely supported on stands. Wheels will be rotating under power & if they contact the ground or debris becomes lodged between the wheels & ground, the chippers could drive off the stands.

4. Remove 1/4" plug (Fig. 27) on the "CPG" port of the hitch manifold and insert a 600 psi gage with the necessary adapters to hook to an 04MB port.

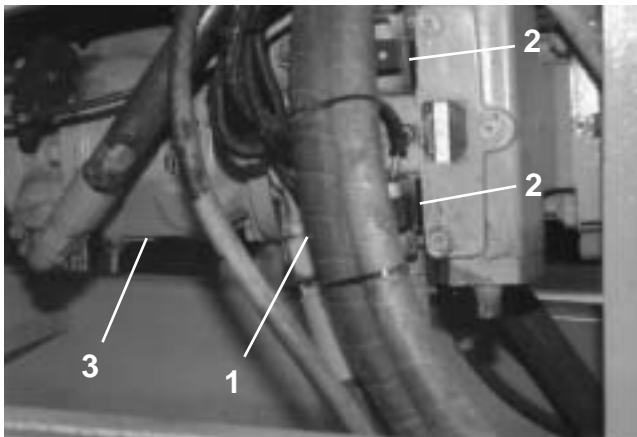

Figure 20. Hydrostatic Pump

1. Hydrostatic Pump
2. Fwd & Rev Solenoids
3. 1st Implement Pump

5. Make sure the gate valve (Fig. 22) in the suction tube is turned full counterclockwise (open) with sleeve and handle installed. Do not attempt to start the engine with the gate valve closed. This will block the flow to the pumps and cause cavitation.

CAUTION! DO NOT CRANK ENGINE WITH GATE VALVE CLOSED. DOING SO WILL CAUSE DAMAGE TO THE HYDRAULIC PUMPS

6. Turn ignition key "on" with the run/idle switch in the idle position. Turn key to "start" and crank engine with starter until seeing at least 40 to 60 psi on the charge pressure gage.

DO NOT CRANK FOR MORE THAN 30 SECONDS.

Wait at least 2 minutes before cranking again. If no pressure reading can be obtained after 2 or 3 attempts, the starter may not be cranking the engine fast enough to develop charge pressure.

7. Hook up the 23 pin round connector.

8. Turn ignition key to "start" and release, letting engine run at idle. Observe the charge pressure for a reading within 30 seconds. Once a reading is seen, allow the engine to idle for about 10 minutes.



Figure 21. Engine Left Side

1. 23 Pin Connector

During filling of all lines and components, the charge pressure can surge between 50 and 500 psi. As the system fills, surging will decrease and the charge pressure should settle down to a steady reading of 400 psi.

WARNING

Be certain that machine is securely supported on stands. Wheels will be rotating under power.

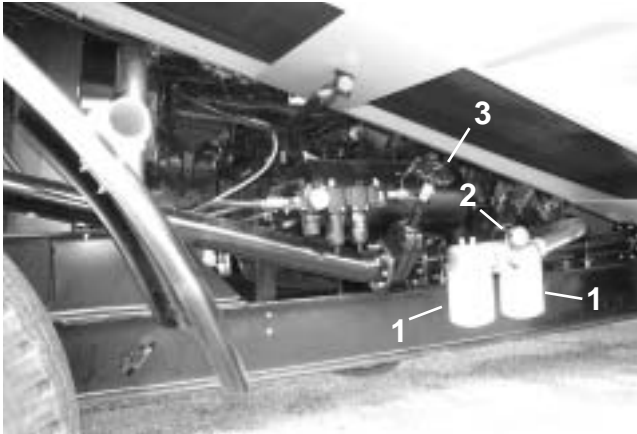

Figure 22. Suction Filters

1. Suction Filters 2. Suction Gage 3. Gate Valve

9. Shut down engine, remove all gages and replace all plugs or caps. Recheck fluid levels after 15 minutes and add as necessary to bring to level of sight eyes in each tank.

Gate Transducer Adjustment

1. Place the Drive/Park selector in “PARK”
2. Hold the CAL switch down and start the engine. Release the CAL switch once the computer beeps three times. This will access the computer set up screens.
3. Scroll down until the display reads LEFT GATE NULL. Note that on a fixed hopper the right gate is not used. This value should be around 0.0. If it is not, verify that the gate is closed. There should be 1/16” between each gate and the spreadroll. Once the gate is shut, press the CAL switch down to set the closed value (null).
4. Once the null is set, scroll down to the next screen, LEFT GATE SCALE. Hold the gate override pushbutton down and monitor the display. The display should show 4.00” while the override is activated. If it does not, verify that the gate is fully open. Once the gate is fully opened, press the CAL switch down while holding the override to set the opening to 4.00” When the gate override is released, the display should go back to 0.00”

It is recommended to try and set the gates using the computer set up screens prior to physically making any

adjustments to the potentiometer itself. If the gates cannot be set using the set up screens, or a new gate potentiometer is to be installed, the following procedure should be used.

1. Place the Drive/Park selector in “PARK”.
 2. Start the engine and run it at about 1000 rpm.
 3. Check that the gate switch is turned off and the gates appear to be closed and then shut the engine off.
 4. To insure that the gates are fully closed, swap the connectors on the gate open and close valve and restart the engine. Depress the gate override button which will fully close the gates. While holding the override button down shut off the engine. There should be 1/16” between each gate and the spread roll.
 5. Replace the connectors in their correct positions.
 6. Enter the Set up access screens by holding the “Cal” switch down while turning the key on. Do not start the engine. Scroll down to the left gate null setting, and set the null to zero by depressing the “Cal” switch. The screen should change to 0.0. Then scroll down to the save screen and save the value.
 7. Using needle probes on a digital voltmeter, measure the voltage between the red and black wires at the gate transducer. The value should be 5.0 volts DC. Next, check the voltage between the blue and black wires. This value should be between 0.5 and 1.5 volts DC.
 8. If the value measured in step 7 is not within the specified tolerance, remove the transducer cover on the hopper.
 9. Loosen the transducer mounting bolts and rotate the transducer as necessary to get the 0.5-1.5 volt DC reading.
 10. Retighten the mounting bolts.
 11. Recheck the reading.
 12. Start the engine and depress the gate override button to fully open the gates. While depressing the override button, shut the engine off. The gates should remain fully open. Turn the key back on and measure the voltage between the blue and black wires. The voltage should be 3.5 to 4.5 volts DC. Restart the engine and let the gates close and recheck that the closed value is still within the specified range of 0.5 -1.5 volts.
- If it is, enter the set up screens while starting the engine and scroll down to the appropriate gate scale screen.
13. Depress the override button to fully open the gates and then depress the cal switch. The reading should change to 4.00.

14. Release the override button and scroll up to the “Gate Null” screen to check the reading. If it is no longer at ”0”, depress the override button and scroll down to the “Gate Scale” screen. Depress the override button and while depressing the override button, depress the “Cal” button to set the scale.

15. Repeat these two steps as required until the readings get to “0” and “4” or until they no longer change.

16. Upon completion, scroll to the save screen and exit set up by depressing the “Save” button.

 WARNING
Never put hands in between gate and spread roll or gate and rear of hopper to clear an obstruction. The gate could move at any time and cause severe injury.

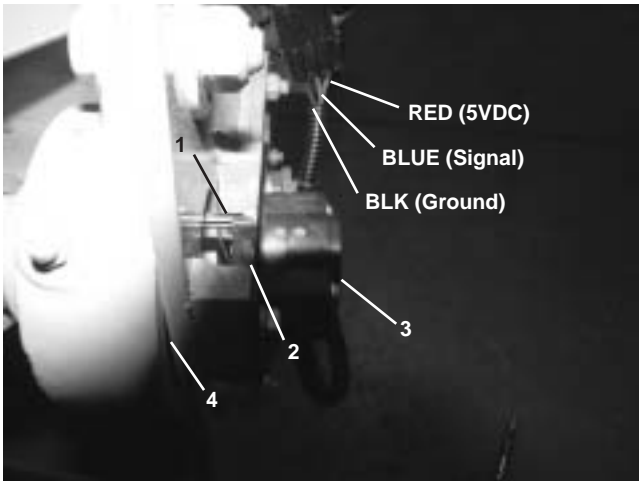

Figure 23. Hopper Transducer

- | | |
|---------------|--------------|
| 1. Drive Pin | 2. Lever Arm |
| 3. Transducer | 4. Bearing |

Air Pressure Adjustments

1. Set the main pressure regulator at 90 psi. (Fig 24)

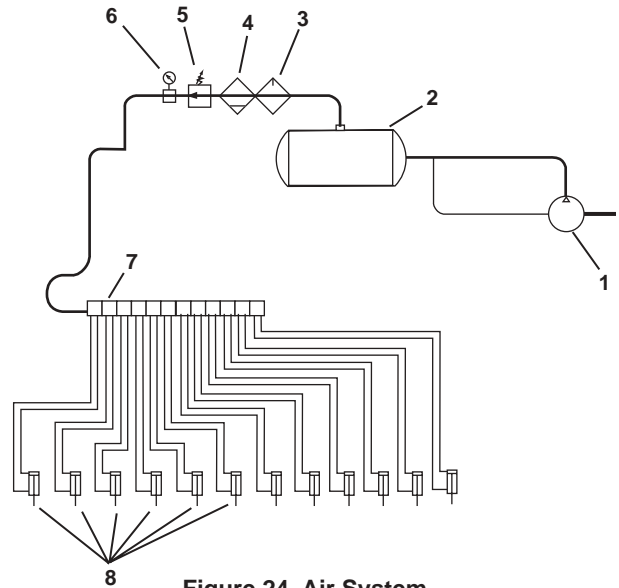

Figure 24. Air System

- | | |
|-------------------|------------------------|
| 1. Compressor | 2. Reservoir |
| 3. Air Oiler | 4. Water Separator |
| 5. Main Regulator | 6. Main Pressure Gage |
| 7. Valve Bank | 8. 1 FT Gate Cylinders |

Pressure Settings For Hydrostatic Drive Pump (Rexroth AA4VG125 Pump)

The pressure settings consist of two (2) high pressure cross port relief valves (forward and reverse) and the pressure over-ride (pressure cut-off) for the AA4VG125 pump. The adjustment procedure is as follows:

1) Install 10,000 psi pressure gages in ports M_A and M_B located on the topside of the pump, as installed.

These ports are -04 SAE O-ring.

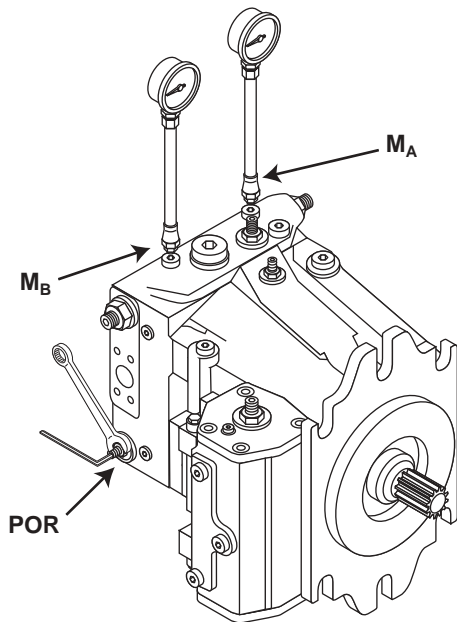

Figure 25. POR Setting

2) The pressure over-ride (POR) should be turned all the way **IN** to be able to obtain the highest possible pressure cut-off setting. Turn screw in (clockwise) until resistance is encountered. Do not force the adjustment past this point. The POR adjustment is located below the curb side high pressure port. The adjustment will require a 4mm allen wrench and a 13mm box wrench. The protective plastic cover may have to be removed to gain access to the POR adjustment.

3) Set the forward and reverse high pressure cross-port relief valves (Relief valves A & B) to approximately 7,000 psi. To do this, first disable the parking brake release circuit by disconnecting the weatherpack connector at the parking brake release solenoid. This solenoid is located on the hydraulic manifold under the center deck cover below the operator's station. Of the three solenoids on this manifold, it is the small single coil located to the front of the manifold. Disabling this cir-

cuit will insure the chipsreader will not move while checking pressures. Once the parking brake release has been disabled, unhook the brake pressure switch, if equipped. The switch is located on the hose coming from the foot pedal. Apply foot pedal brake and push joystick forward developing maximum system pressure. Check reading on gage in port M_A for forward high pressure. Should the pressure need adjusting, you may have to remove the protective plastic cover located above the high pressure port on the street side of the pump. Turn adjusting screw in (clockwise) to increase relief setting. This adjustment requires a 5mm allen wrench and a 17mm box wrench. Once forward cross-port relief valve (relief valve A) has been set to 7000 psi, repeat above procedure for reverse (relief valve B). Adjustment for this relief is located above the curb side high pressure port.

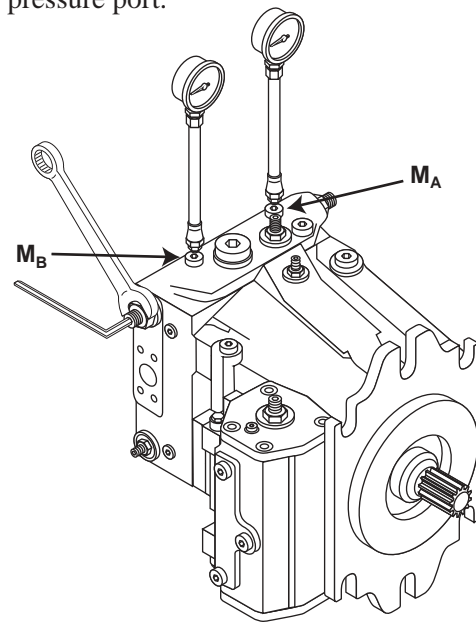

Figure 26. High Pressure Relief Setting

CAUTION

When setting the two high pressure cross-port relief valves, **DO NOT** leave the pump on stroke for more than a few seconds at a time. The flow is being short circuited from the pump inlet and a lot of heat is being generated.

The Correct procedure is to:

Put the pump on stroke and see where the relief valve pressure setting is at but not leaving the pump on stroke for more than a few seconds

Put the pump to neutral

Make an adjustment to the relief valve

Put the pump on stroke again and see where the pressure level is at

Repeat the above process as many times as necessary until the correct pressure level is obtained.

4) Once the two high pressure relief valves set correctly for forward and reverse, set the Pressure Override Valve to 6500 psi. To do this, adjust the P.O.R. screw out (counter clockwise) until the high pressure reads 6500 psi. The P.O.R. adjustment is the same screw that was turned in fully in step 2. There is only one setting for this relief that controls forward and reverse.

⚠ CAUTION

When making the pressure over-ride adjustment, the pump should be put on stroke only for a few seconds at a time until you are sure that the pressure cut-off setting is **Below** the setting of the two high pressure cross-port relief valves.

Once the pressure over-ride setting is below that of the two high pressure cross-port relief valves, the pump can be left on stroke without any problems as there will be no flow across the high pressure cross-port relief valves.

Remove the gages.

Setting the Charge Pressure

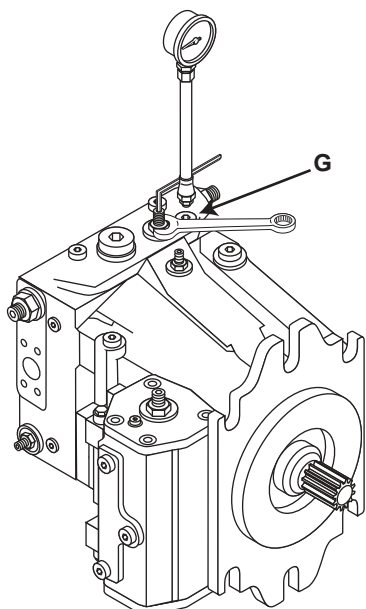

Figure 27. Charge Pressure Adjustment

1) Install 600 PSI gage in the “CGP” port on the hitch manifold (Fig 32, Ref 1). The gage will require a size 04 male boss end to plumb to the gage port. With

engine at low idle, the charge pressure should read 400 psi.

2) If the pressure is below 380 or above 420, an adjustment should be made to the charge pressure relief valve. To access the relief valve adjustment, you may have to remove the protective plastic cap located on the topside of the pump beside the port marked “G” (Fig 27). Using a 17mm box wrench with a 5mm allen wrench, loosen the jam nut and turn set screw clockwise if the pressure is low. If the pressure is high, loosen the jam nut and turn set screw counterclockwise. One turn is equal to 55 psi.

Remove the gage.

Pressure Settings For Auxiliary Pump (Rexroth A10VO74 Pump)

This pump is stacked on the back of the drive pump. Flow for the left and right conveyors, the spreadroll, and the gate cylinder is supplied by this pump on a fixed hopper chipspreader. The pump has an internal high pressure relief setting and a standby or margin pressure setting. The high pressure relief should be set to 3000 psi, and the standby pressure set to 450 psi.

Relief Valve Settings

1) Install a 1000 psi gage, with a shutoff valve in the port marked “TP” on the conveyor manifold located on top of the hydraulic reservoir (Fig 29 Ref 2). This port is SAE 04 and requires a 9/16 wrench to remove the plug.

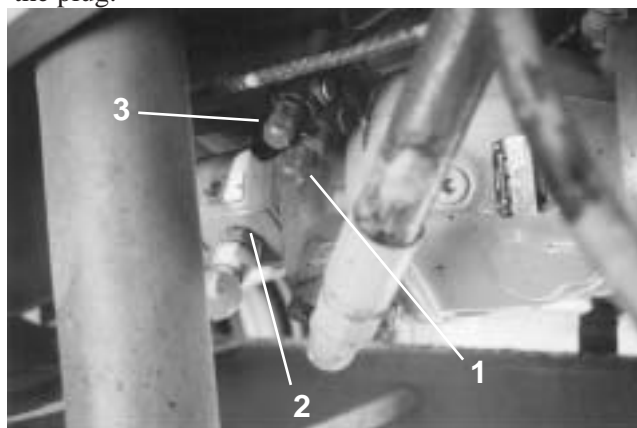

Figure 28 Pumps

- 1. High Pressure Valve
- 2. Fixed Displacement Pump
- 3. Standby Pressure Valve

2) Disconnect the electrical connectors from gate valve. Make sure the left and right conveyor switches

are in the “off” position and the thumb switch on the control handle is in the center position before starting the engine. Make sure the shutoff valve is shut. Failure to do so could result in a blown gage. Start the engine and run at low idle and monitor the gage pressure. The standby pressure should be 450 psi.

3) To make an adjustment, use a 17mm wrench to remove protective cap from set screw. The standby pressure adjustment is the higher adjustment of the two adjustments at the rear of the pump (Fig 28, Ref 3). Loosen the jam nut on the rear pump and turn the set screw until the pressure reads 450 psi on the gage. Replace protective cover once correct pressure is set. Tighten the jam nut. Shut the engine off.

4) Install a 5000 psi gage in the port marked “TP” on the conveyor manifold located on top of the hydraulic reservoir (Fig 29, Ref 2). Remove the pressure hose plumbed to the left conveyor at the manifold and cap the adapter in the port marked “A2” with a 1/2” (08) JIC hydraulic cap.

2) With engine running at half throttle, turn on left conveyor and monitor gage pressure. If the pressure reading is below 2950 psi or above 3050 psi an adjustment should be made.

3) To make an adjustment, use a 17mm wrench to remove protective cap from relief set screw located to the rear of the pump on the curbside of the chipspreader. Of the two adjustments at this location, the high pressure relief is the lower one of the two. If pressure is low, loosen jam nut and turn set screw clockwise using a 5mm allen wrench. If pressure is high, loosen jam nut and turn set screw counterclockwise. Replace protective cover once the correct pressure is set.

4) Reinstall the hose removed in step 1 and remove gage.

5) Remove gage and reinstall the 1000 psi gage with the shutoff closed. Restart engine and let it idle. Open the shutoff valve and verify that the standby pressure is still at 400 psi and adjust if necessary.

4) Reconnect the electrical connectors on the gate valve and remove the gage.

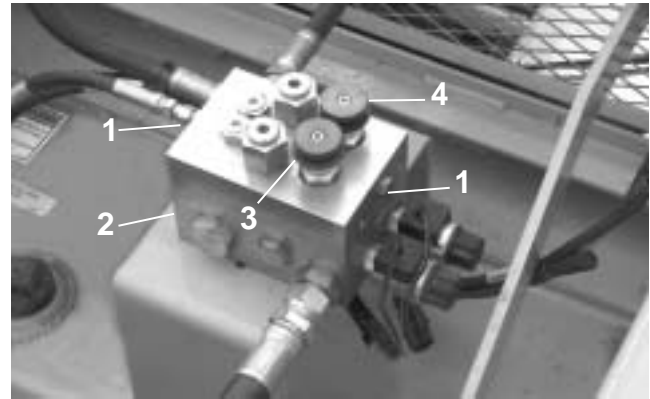

Figure 29. Conveyor Manifold

- 1. "LS" Port
- 2. "TP" Port
- 3. Lt Conv Speed Control
- 4. Rt Conv Speed Control



CAUTION

Do not set pressure above 3000 psi. The hydraulic components are rated for 3000 psi. Failure of these components could occur at system pressures above 3000 psi.

Pressure/Flow Settings For Actuator Valving

(Functions supplied by pressure compensating auxiliary pump)

Note: Other than individual circuits which require reduced pressure for mechanical purposes, the main system relief is set at the pump.

Gate Cylinder Relief Valve

The relief setting for the gate cylinder relief valve should be set to 1300 psi.

1) Install 2000 psi gage in “TP” port of gate cylinder manifold located just behind conveyor manifold on hydraulic reservoir (Fig 30 Ref 1). This port is SAE 04 MB and requires a 9/16 wrench to remove the plug.

2) With engine at high idle, depress and hold the gate override push-button and monitor pressure. If pressure is below 1250 or above 1350, an adjustment should be made.

3) To adjust pressure, use 9/16" box wrench to loosen jam nut on set screw located on the gate manifold on top of the reservoir (Fig 30 Ref 2). If pressure is low, turn set screw clockwise. If pressure is high, turn set screw counterclockwise.

4) Remove gage.

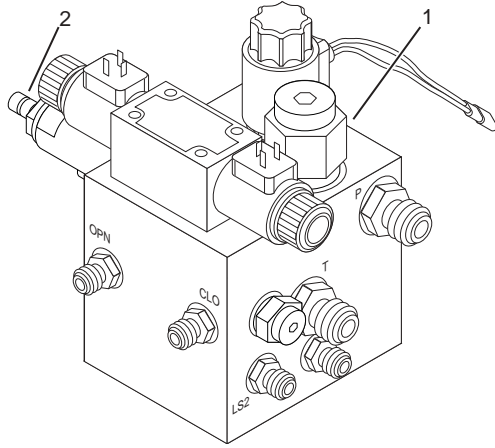

Figure 30. Gate Relief Valve

- 1. "TP" Port
- 2. Gate Relief Valve

Spreadroll Speed Adjustment

The spreadroll should be set at 96 rpm.

1) With engine at high idle and park/drive switch in park position, push joystick slightly out of neutral and depress right side of thumb switch engaging the gate/spreadroll circuit. Time the spreadroll with a stopwatch or a low speed tachometer to determine the revolutions per minute.

2) To adjust the speed, loosen the jam nut on the spreadroll flow control valve using a 9/16" box wrench. This valve is located on the gate manifold on the hydraulic reservoir. Using a 1/4" allen wrench, turn set screw clockwise to decrease the speed of the spreadroll, or counterclockwise to increase the speed.

Conveyor Speed Adjustment

The conveyors should be set to a speed that allows the aggregate to fall into the front hoods. Running the conveyors faster than this **does not** increase the amount of aggregate delivered to the front hopper but **does** cause premature wear of the hood frames and create unnecessary noise.

1) To adjust the speed of the conveyor (left or right)

loosen jam nut by hand on the flow control valve for the conveyor to be changed (Fig 31 Ref 3 & 4). The adjustments are located on the conveyor manifold on the hydraulic reservoir. Turn the aluminum knob attached to the set screw clockwise to decrease conveyor speed or counterclockwise to increase speed. Hand tighten jam nut once speeds are set.

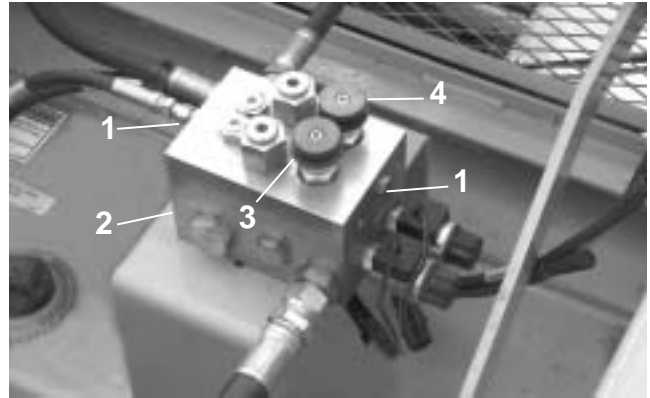

Figure 31. Conveyor Manifold

- 1. "LS" Port
- 2. "TP" Port
- 3. Lt Conv Speed Control
- 4. Rt Conv Speed Control

Fixed Displacement Auxiliary Pump

The fixed displacement pump (gear pump) is mounted to the back of the pressure compensating auxiliary pump. This pump supplies flow for the power steering and hitch functions. The gear pump does not have an internal relief and relies on external valving to govern relief pressure.

Pressure Settings For Actuator Valving Supplied By Fixed Displacement Pump

Main Relief Pressure (MP)

The main relief pressure should be set to 2000 psi. The steering motor operates at this pressure.

1) Install 3000 psi gage in port marked "MP" on steering/hitch manifold located under center deck cover below operators station. This port is SAE 06 MB and requires a 1/4" allen wrench to remove plug. (Figure 32, Ref 2)

2) With engine at or above 1000 rpm, turn front wheels full left or right until steering cylinder is fully stroked. Hold wheels in this position and monitor pressure.

Note: Engine must not be running to adjust set screw. When cap is removed, oil will flow through valve and spray out top of valve. Shut the engine off before proceeding to make any adjustment.

3) If the pressure is low, remove cap from top of relief valve using vise grips (Figure 32, Ref 1) and adjust set screw clockwise using a 1/4" allen wrench. If pressure is high, adjust set screw counterclockwise.

Pilot Pressure (PP)

The pilot pressure should be set to 250 psi. The hitch raise/lower function operates at this pressure.

1) Install 600 psi gage in port marked "PP" on steering/hitch manifold. This port is SAE 06 MB and requires a 1/4" allen wrench to remove plug.

2) With engine at or above 1000 rpm, monitor pressure.

Note: Engine must not be running to adjust set screw. When cap is removed, oil will flow through valve and spray out top of valve. Shut the engine off before proceeding to make any adjustment.

3) If the pressure is low, remove cap from top of relief valve using vise grips (Figure 32, Ref 3) and adjust set screw clockwise using a 1/4" allen wrench. If pressure is high, adjust set screw counterclockwise.

Reduced Pressure (RP)

The reduced pressure should be set to approximately 120 psi. This can vary due to back pressure in the return line to the reservoir. The hitch release function operates at this pressure.

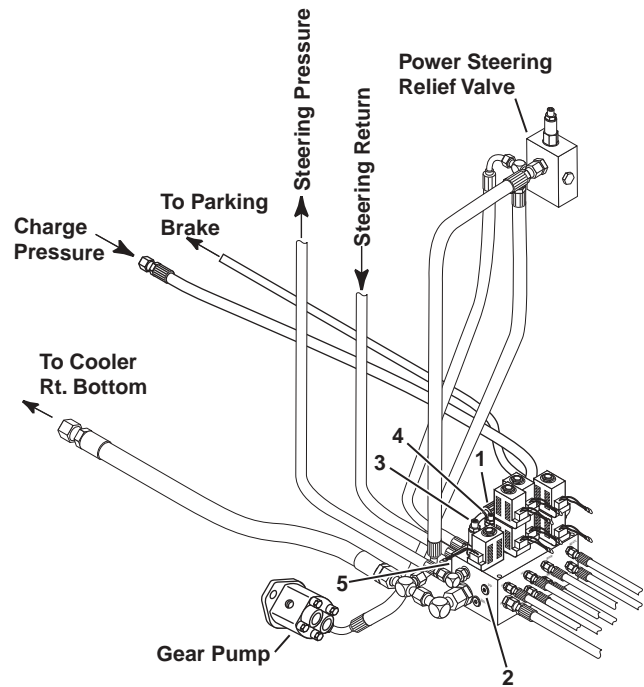

Figure 32. Hydraulic Control Assembly

1. Charge Pressure Check Port
2. Pilot Pressure Check Port
3. Main Pressure Relief Valve
4. Pilot Pressure Relief Valve
5. Main Pressure Check Port

1) Install 600 psi gage in port marked "RP" on steering/hitch manifold. On 2wd units, this port has a 1/4" JIC hydraulic tee installed with a 1/4" JIC cap. Remove cap to access the reduced pressure. This will require a 1/4" female JIC adapter on the gage. On 4WD units, the port is plugged. This port is SAE 06 MB and requires a 1/4" allen wrench to remove plug.

2) Once gage is installed, run engine at or above 1000 rpm and monitor pressure.

3) If pressure is low loosen jam nut with 3/4" box wrench and turn set screw clockwise using 1/4" allen wrench. If pressure is high, turn counterclockwise. If pressure can not be set down to 120 psi, back set screw full out (counterclockwise) and turn back in 10-15 psi.

4) Remove gage

Truck Hitch Arrangement

1. Trucks ranging in size from four to ten yards are handled easily by an ETNYRE Chip-Spreader.

2. An apron on the rear of each truck will be quite helpful.

3. For truck hitch arrangement, see truck hitch tow bar illustration below.

Truck Hitch Tow Bar Illustration

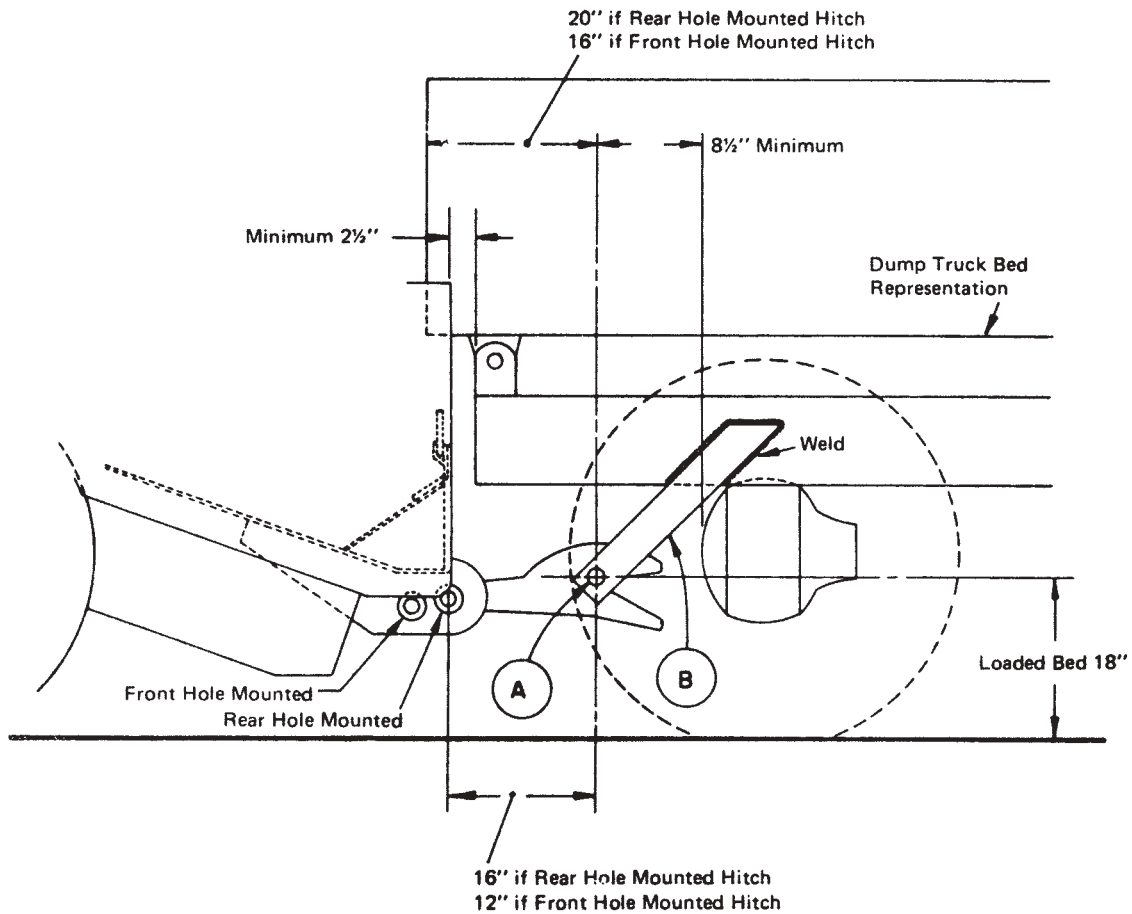

- A. 3390451-Cold Rolled Round 1 3/4" dia. x 36" long
- B. 3390450-Hot Rolled Flat 1/2" x 4" x 18" long (2) Req'd

Caution And Instruction Plates

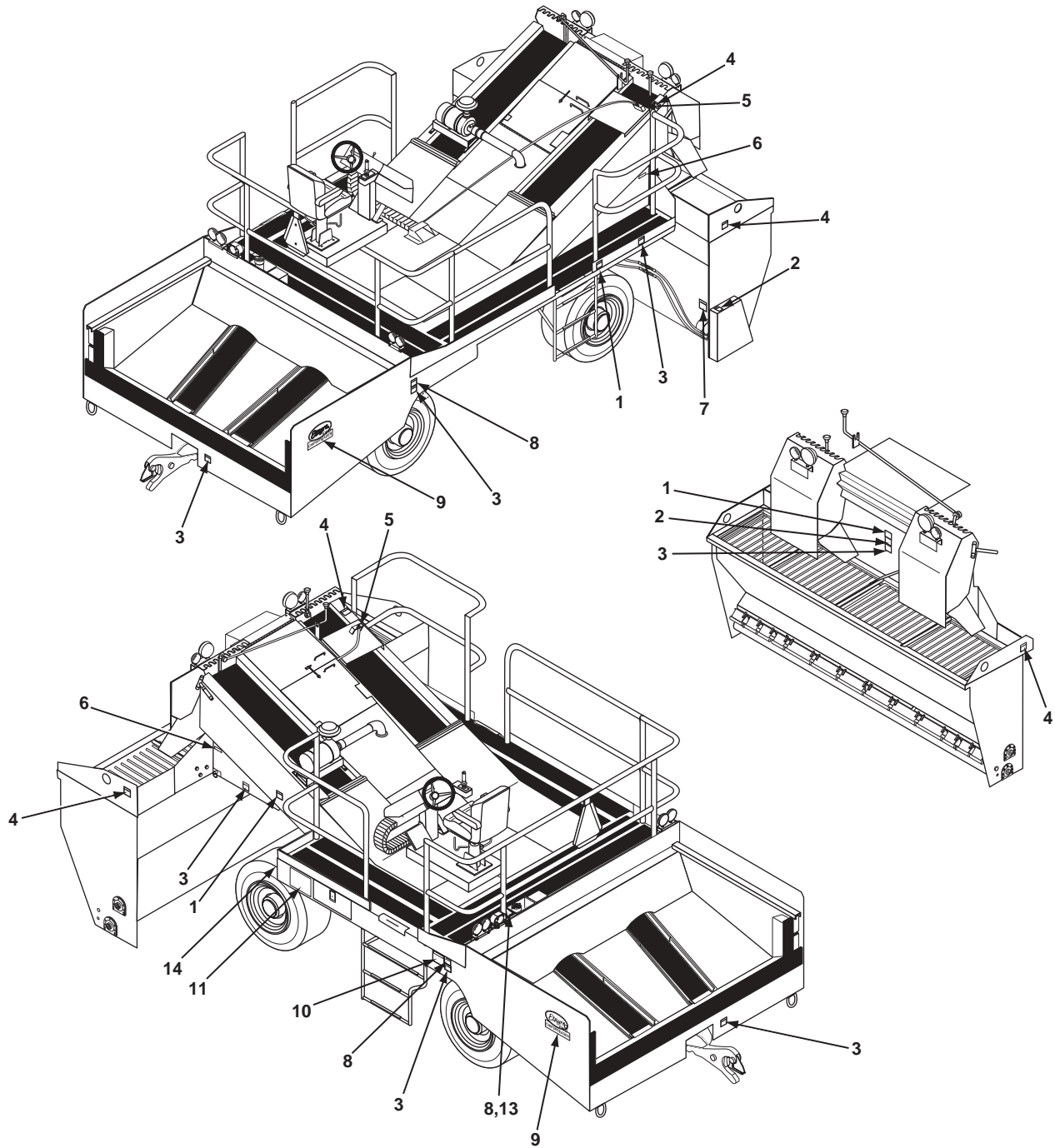

MAINTENANCE

REF	PART NO.	QTY	DESCRIPTION	REF	PART NO.	QTY	DESCRIPTION
1	3390681	3	Decal: WARNING, Remain Clear	9	3101999	2	Decal-Chips, FWD
2	3390683	2	Decal: CAUTION, Shields	10	3102000	2	Decal-Chips, Quad
3	3101652	6	Plate Hydro, Towing Warning	11	3100716	1	Plate-CAUTION, General
4	3101717	3	Label: WARNING Hopper (STAY OFF)	12	3102054	1	Lube-Chart
5	3101268	1	Plate-Hydro, Hitch Release	13	6000758	1	Emblem-Vehicle, Slow Moving
6	4421557	2	Placard-Shafts, Grease Daily	14	3360180	1	Plate-Fill W/Diesel Fuel Only
7	3190476	1	Label: Spread Hopper, Hose Attach		3100689	1	Name Plate-Chipsreader, Brass
8	3101247	3	Plate-WARNING, No Drill or Weld				

Lubrication

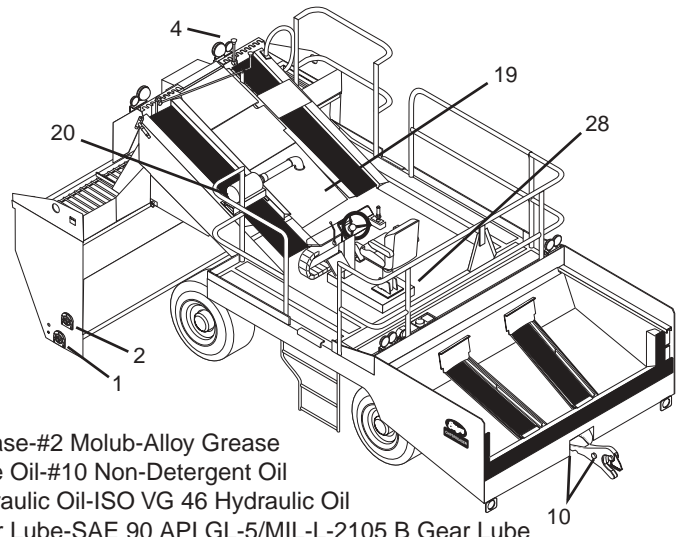
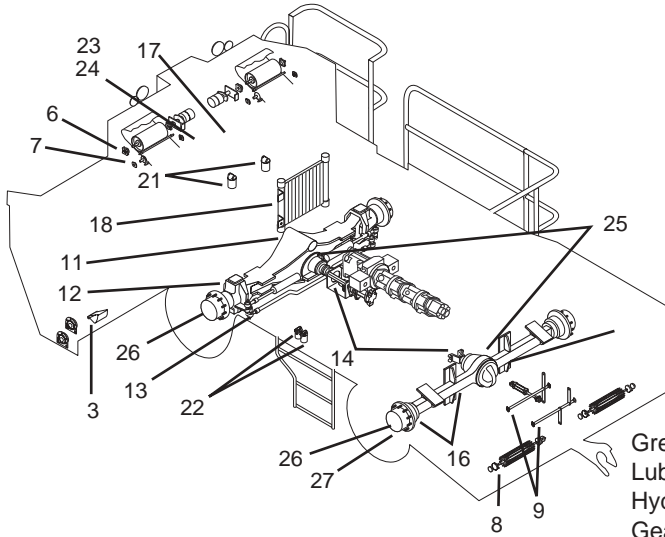

Grease-#2 Molub-Alloy Grease
 Lube Oil-#10 Non-Detergent Oil
 Hydraulic Oil-ISO VG 46 Hydraulic Oil
 Gear Lube-SAE 90 API GL-5/MIL-L-2105 B Gear Lube

MAINTENANCE

Interval	Point	Identification Points	No. of	Lubricant	Quantity
Weekly	1	Cartridge Bearing (Both Ends)	4	Grease	Springly
	2	Bearing Disconnect	1	Grease	Springly
	3	Front Hopper Gates	A/R	Grease	Springly
	4	Baffle Shaft (Both Hoods)	2	Grease	Springly
	5				
	6	Flange Bearing-Conveyors	4	Grease	Springly
	7	Flange Bearing-Return Idler	4	Grease	Springly
	8	Bearing-Tail Pulley	4	Grease	Springly
	9	Bearing-Hitch Levers	4	Grease	Springly
	10	Bearing-Truck Hitch	4	Grease	Springly
	11	Shaft-Front Axle Pivot	2	Grease	Springly
	12	Spindle-Front Axle	4	Grease	Springly
	13	Tie Rod-Front Axle	6	Grease	Springly
	14	Universal Joints-Drive Line	2-2wd 4-4wd	Grease Grease	Springly Springly
	15	Bearing-Slack Adjuster (2WD only)	2	Grease	Springly
	16	Bearing-Camshaft (2wd only)	4	Grease	Springly
	17		-	Hydraulic Oil	Add When Low
	18	Hydraulic Oil Cooler	-	-	Clean A/R
	19	Engine Oil	1	Engine Original	Engine Manual
When Indicator turns red	20	Filter-Engine Air Intake	1	-	Filter Element
Yearly	21	Filter-Return*	2	-	Filter Element
	22	Filter-Suction*	2	-	Filter Element
	23	Magnet-Hydraulic Reservoir	1	-	Clean A/R
	24	Breather-Hydraulic Reservoir	1	-	Filter Element
	25	Differential Housing**	1-2wd 2-4wd	Gear Lube Fill Gear Lube Fill	
	26	Planetary Wheel End**	2-2wd 4-4wd	Gear Lube Fill Gear Lube Fill	
	27	Hub-Rear Axle (2wd only)**	2	Gear Lube Fill	
	28	Roller Chain-Power Seat	2	Lube Oil	Springly

(1) On new machines change filter elements after first two weeks of operation. After initial change (two weeks) replace elements on an annual basis unless hydraulic system has been worked on and contamination introduced into the system. Change elements anytime it is possible that contamination has been introduced to the system.

(2) On new machines drain lubricant from axles after first 50 hours of operation and fill with SAE 90 API GL-5/MIL-L-2105 B gear lube. After initial change (50 hours) change lube on an annual basis.



Something Wrong with this manual?

If you find inaccurate or confusing information in this manual, or just have a suggestion for improvement, please let us know.

Mail or FAX this form to us at: E. D. ETNYRE & CO. 1333 S. Daysville Rd.
 Oregon, Illinois 61061 • Fax: 800-521-1107 • www.etnyre.com
 Attn: Service Manager

Recommended changes from: _____

Address _____

City, State, Zip _____

Phone _____

Date Sent _____

Manual Number (upper right corner of front cover) _____

Manual Title _____

Explain the problem in the space below.

Page Number	Reference Number	Paragraph Number	Figure Number	Problem (please be specific)

MAINTENANCE