

M-114-08

Serial Number S3985 and up
with BT1 Controls



Black-Topper® CENTENNIAL Asphalt Distributor With BT 1 Controls

For Units with Variable Width Spray Bar



Operation



Maintenance



Safety



E.D. ETNYRE & CO. – 1333 S. Daysville Road – Oregon, Illinois 61061

Phone: 815-732-2116 or 800-995-2116 – Fax: 800-521-1107 – www.etnyre.com

M-114-08

Black-Topper Centennial Operation, Maintenance, and Safety Manual

BLACK-TOPPER Distributor with Variable Width Spraybar and BT-1 Controls

Serial Number S3985 and up

WARRANTY

E. D. Etnyre & Co. warrants to the original Purchaser, it's new product to be free from defects in material and workmanship for a period of twelve (12) months after date of delivery to original Purchaser. The obligation of the Company is limited to repairing or replacing any defective part returned to the Company and will not be responsible for consequential damages or any further loss by reason of such defect.

The company excludes all implied warranties of merchantability and fitness for a particular purpose. There are no warranties, express or implied, which extend beyond the description of the goods contained in this contract.

This warranty does not obligate the Company to bear the cost of machine transportation in connection with the replacement or repair of defective parts, nor does it guarantee repair or replacement of any parts on which unauthorized repairs or alterations have been made or for components not manufactured by the Company except to the extent of the warranty given by the original Manufacturer.

This warranty does not apply to:

- (1) Normal startup services, normal maintenance services or adjustments usually performed by the selling dealer, factory service representative or customer personnel.
- (2) Any product manufactured by E. D. Etnyre & Co. purchased or subjected to rental use.
- (3) Any product or part thereof which shows improper operation, improper maintenance, abuse, neglect, damage or modification after shipment from factory.
- (4) Any product or part thereof damaged or lost in shipment. Inspection for damage should be made before acceptance or signing any delivery documents releasing responsibility of the delivering carrier.

This warranty and foregoing obligations are in lieu of all other obligations and liabilities including negligence and all warranties of merchantability or otherwise, express or implied in fact or by law.



WARNING

Do not use this machine for any operation that is not described in this manual.

If you have any questions about operation of this machine, contact the Etnyre Service Department at 1-800-995-2116 or 1-815-732-2116.

Operations that are not approved could cause serious injury or death.



WARNING

Diesel engine exhaust and some of its constituents are known to the State of California to cause cancer, birth defects, and other reproductive harm.

Please note this warning and remember:

- Always start and operate the engine in a well ventilated area.
- If in an enclosed area, vent the exhaust to the outside.
- Do not modify or tamper with the exhaust system. Can cause serious injury or death.

© Copyright 2008 E.D. Etnyre & Co.
All brand names, trademarks and registered
trademarks are the property of their respective
owners. Information contained within this
document is subject to change without notice. All
rights reserved.

Table of Contents

Warning And Instruction Plates	5	Bar Suck Back Override	36
General Safety Instructions	7	Spray Bar Suckback	37
Safety Precautions, Hazard Seriousness Level	7	Flushing Operations	39
WARNINGS	8	Bar Flush (Auto)	39
Fluoroelastomer Handling	8	Bar Flush (Manual)	40
Foaming	10	Unload Operations with External Pump	41
Asphalt Institute	10	Unload Operations with Distributor Pump	43
Introduction	11	Transfer Operations	45
Reporting Safety Defects	11	Heating Product in Distributors	47
Component Location And Identification	12	Heating with Liquid Propane Gas (LPG) Burners ..	47
Rear and Side Components	12	LPG Supply Tank Requirements	47
Spray Bar Components	13	Manual Control Burners	48
Hydraulic Tank Components	13	Burner Operation	48
Cab Control Panel	14	Burners With Outfire Controls	49
Rear Control Panel	17	Burner Operation with Outfire Controls	50
Preparing for Operation	19	Burners with Automatic Ignition and	
Setting Up the Computer	19	Temperature Limiting Control	52
First Screen	19	Burner Operation with Auto Ignition &	
Second Screen	19	Temperature Control	52
Third Screen	20	Electric Driven Burner Diesel Operation	53
Fourth Screen	20	Troubleshooting	54
Fifth Screen	20	Maintenance	55
Sixth Screen	20	Electrode Assembly Adjustments	55
Seventh Screen	20	Burner Air Band Settings	55
Engaging Pump on PTO Equipped Distributors ..	21	Check Ignition Transformer Spark	56
Manual Transmissions	21	Fire Burners	56
Automatic Transmissions	21	Replacing Speed Pickup	56
Spraying Operations	22	Adjusting Spray Bar Nozzle Angle	56
Adjusting the Spray Bar Nozzle Angle	23	Adjusting Spray Bar Height	56
Setting the Digital Memory Presets	23	Servicing the Etnyre P-15 Pump	57
Adjusting the Spray Bar Height	23	Vacuum Check	57
Spraying through the Bar	23	Impeller Installation And Pump	57
Operation	25	General Fuel Data and Heating Terminology ..	58
Tank Capacity	25	Fuel Data	58
Operation Screens	25	Approximate Burner Fuel Consumption	58
First Operating Screen	25	Heating Terminology	58
Second Operating Screen	25	Hydraulic Fluid Requirements	59
Third Operating Screen	26	General Information	59
Information Messages	26	Hydraulic Fluid Requirements	59
Loading	27	Viscosity & Temperature Requirements	59
Loading Through the Manhole	27	Fluid Viscosity Limits For	
Connections and Preliminary Checks	28	Petroleum Based Fluids	59
Check Strainers	28	Fluid Temperature Limits For	
Using the Measuring Stick	28	Petroleum Based Fluids	59
Loading Through the Fill Line	28	Contamination Levels	60
Circulating in the Tank	30	Lubrication Chart	62
Circulating Product in the Bar	32	Etnyre Spraybar Nozzles	63
Spraying (Auto)	34	Serial Number Plate Location	64
Hand Spraying	35	Decimal Equivalent Chart	64

List of Illustrations

Figure 1. Location of Warning and Instruction Plates.	5
Figure 2. Rear and Side Component Identification.	12
Figure 3. Rear Component Identification.	12
Figure 4. Spray Bar Component Identification.	13
Figure 5. Hydraulic Tank Component Identification.	13
Figure 6. Cab Control Panel Components.	14
Figure 7. Rear Control Panel Components.	17
Figure 8. Adjusting the Spray Bar Nozzles.	23
Figure 9. Adjusting the Spray Bar Height.	23
Figure 10. Selector Valve set to Normal Spraying.	23
Figure 11. Valve Positions for Loading Through the Manhole.	27
Figure 12. Using the Measuring Stick.	28
Figure 13. Valve Positions for Loading Through the Load Line.	29
Figure 14. Valve Positions for Circulating in the Tank.	31
Figure 15. Valve Positions for Circulating in the Bar.	32
Figure 16. Valve Positions for Spraying Through the Bar.	34
Figure 17. Valve Positions for Handspray.	35
Figure 18. Valve Positions for Spray Bar Suck Back.	37
Figure 19. Valve Positions for Flushing.	39
Figure 20. Valve Positions for Unload with External Pump.	41
Figure 21. Valve Positions for Unload with Distributor Pump.	43
Figure 22. Valve Positions for Transfer.	45
Figure 23. Manual Control Burner System.	48
Figure 24. Outfire Controlled Burner System.	50
Figure 25. Burner System with Auto Ignition and Temperature Control. ...	52
Figure 26. Electric Burner System.	53
Figure 27. Burner Electrode Adjustments.	55
Figure 28. Electrode Assembly Installation.	55
Figure 29. Nozzle Adjustment.	55
Figure 30. Hydraulic Motor.	56
Figure 31. Nozzle Angle Adjustment.	56
Figure 32. Nozzle Height Adjustment.	56
Figure 33. Etnyre Asphalt Pump.	57
Figure 34. Fluid Cleanliness Chart.	60
Figure 35. Serial Number Plate Location.	64

Warning And Instruction Plates

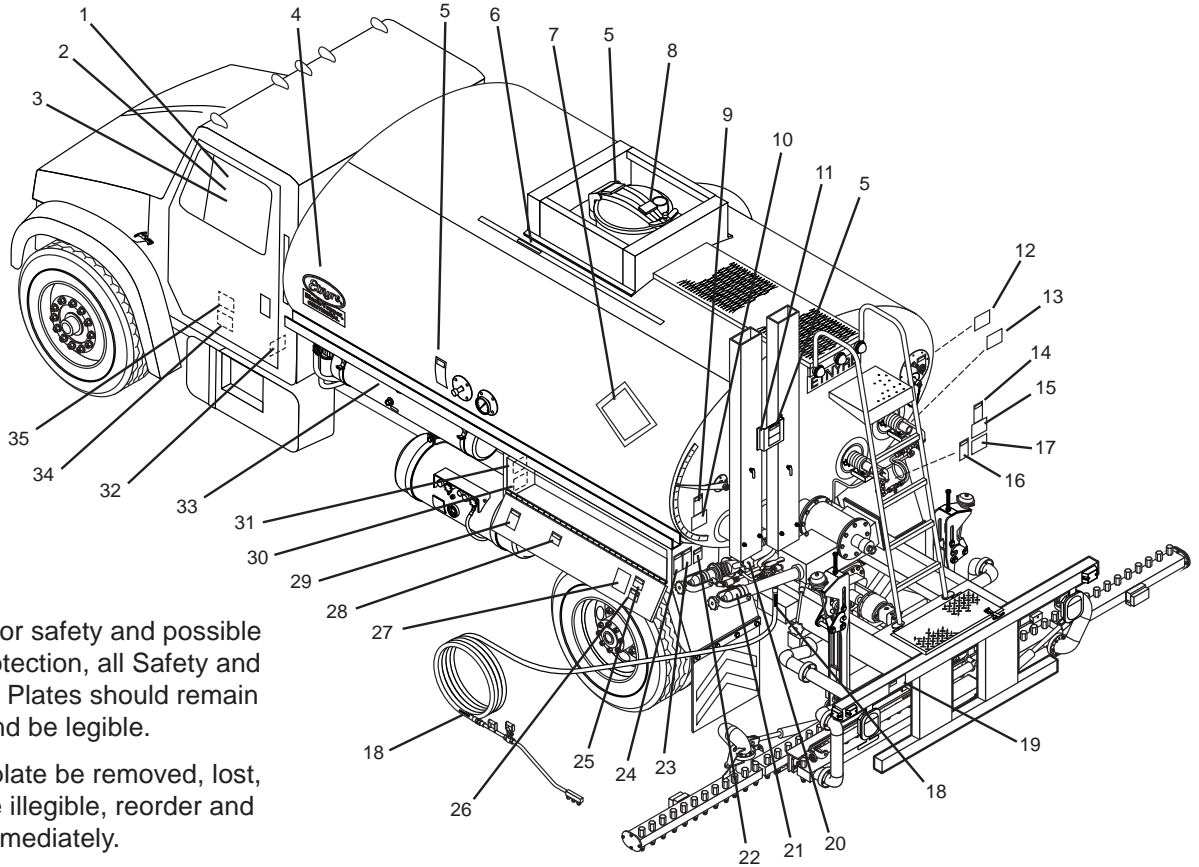

- ⚠** For operator safety and possible liability protection, all Safety and Instruction Plates should remain in place and be legible.
- ⚠** Should a plate be removed, lost, or become illegible, reorder and replace immediately.
- ⚠** If plates become difficult to read because of material coating the surface, clean with solvent.

Ref	Part No.	Qty	Description	Ref	Part No.	Qty	Description
1	6320807	1	Decal-Warn, Master Power	19	6320804	1	Decal-Warning, No Riders
2	6320808	1	Decal-Warn, Electrical Equipment	20	6320803	1	Decal-Gate Valve
3	3390709	1	Decal-Wiring Terminal (Cab Panel)	21	6320801	1	Decal-Gate Valve Close
4	3390696	2	Decal, Blacktopper Centennial	22	6320795	1	Decal- Warning, Fill Line Cap
5	6320797	3	Plate- Caution, Hot Surface	23	6320789	1	Decal- Warning, Asphalt Grades
6	3390645	1	Label-Measuring Stick, 1 Flue	24	3390636	1	Decal- Warning, Flues Covered
	3390656	1	Label-Measuring Stick, 2 Flues	25	6320796	2	Decal- Warning, Before Starting
7	6320272	AR	Placard System (Optional)	26	6320793	2	Plate- Warning, Manuals
8	6320794	2	Plate- Warning, Manhole	27	6320788	1	Decal-Lubrication Chart
9	6320790	1	Decal-Warning, GVWR	28	6320792	AR	Decal- Directions, Fuel Oil Burners
10	6320791	1	Decal-Handspray Operation	29	6320798	1	Decal- Warning, Safety, General
11	3390592	1	Bracket- Mtg, Decal, Hot Surface	30	6320805	1	Decal- All American
12	6320800	1	Decal-Diesel Fuel Only	31	3390655	1	Plate- Name, Distributor S/N, Brass
13	6320809	1	Decal-Instr, Air Oiler	32	2790530	1	Plate-Name, Spec, 178.345
14	6320784	1	Decal-Warning, Personal Protection	33	6320786	1	Plate-Instr, Hydraulic Oil
15	6320802	1	Decal-Warning, Handspray Hose	34	6320796	1	Decal- Warning, Before Starting
16	6320799	1	Plate- Warning, Burner, General	35	6320793	1	Decal- Warning, Manuals
17	6320787	AR	Decal- Directions, LPG Burner				AR = As required
18	6320785	2	Decal-Warn, 1" Handspray Hose				
	6320806	2	Decal-Warn, 3/4" Handspray Hose				

Figure 1. Location of Warning and Instruction Plates.



NOTICE

The handling of Cationic Emulsions (CRS-2, CMS-2, CSS-1 and CSS) may create an environment within the Asphalt Distributor that can be corrosive to carbon steel and cast iron.

- Cationic Emulsions are widely used within the industry.
- Cationic Emulsion is manufactured with asphalt, water, emulsifiers and hydrochloric acid. The chemistry of individual emulsions varies in asphalt content and Ph levels.
- Tanks and spray mechanisms used with Cationic emulsions may experience corrosion
- It is believed the chemistry of the emulsion - specifically the residual fumes promote the corrosion
- Etnyre Distributors are compatible with Cationic Emulsions provided that certain precautions are taken.
- Prior to placing a distributor in to service with Cationic Emulsion, it should be loaded with an AC or MC type material to develop a protective coating.
- Periodic inspection of the tank and spray system should be preformed in the normal course of operation.
- It is recommended that distributors used in Cationic service be flushed periodically and at the end of the season with an AC, MC or cutback to remove the corrosive materials and to provide a protective coating.
- Increasing the quantity of flushing material during daily suck back and cleanout operations will also help to minimize corrosion damage.
- Dilution is the solution.
- Additional information can be acquired from your Emulsion supplier as well as the Asphalt Institute or the Asphalt Emulsion Manufactures Association.



WARNING

Take extra care and follow recommended procedures when alternating asphalt materials especially when loading hot product, over 212 degrees Fahrenheit (100 degrees Celsius), on to a tank and system previously in Emulsion service.

General Safety Instructions

The operation of a bituminous distributor normally requires handling of liquid products at elevated temperature. Also, these liquids may be of a volatile nature. A heating system is supplied to raise or maintain the product temperature, and these systems use highly combustible fuels. As with any type of construction equipment, there are certain hazards associated with careless or improper operation.

Safety warnings have been provided to call attention to any potentially hazardous situation that may cause property damage, personal injury or death to the operator or bystanders. These safety warnings will be shown at various times throughout this manual, as they are applicable to the subject being presented. These safety warnings are identified by the following warning symbols:

Safety Precautions, Hazard Seriousness Level

You will find safety information boxes throughout this manual. These boxes contain information alerting you to situations or actions to avoid.

Signal words (DANGER, WARNING, and CAUTION) are used to identify levels of hazard seriousness. Their selection is based on the likely consequence of human interaction with a hazard. Definitions of hazard levels are as follows.



DANGER - Immediate hazards which will result in severe personal injury or death.



WARNING - Hazards or unsafe practices which could result in severe personal injury or death.



CAUTION - Hazards or unsafe practices which could result in minor personal injury or product or property damage.

All of these warnings are listed below and they also appear throughout the manual. In addition to these, you will find notes throughout the manual.

NOTE - A note provides general information that the operator should be aware of when performing an operation.



DANGER

To avoid an extreme fire hazard or explosion, NEVER use gasoline as fuel in diesel or fuel oil burners.



WARNING

A fully charged dry chemical type fire extinguisher must be within easy reach whenever the burners are operating or there is an open flame near the Distributor. The minimum capacity of the fire extinguisher should be 10 pounds.

Please Note This Warning and Remember:

- Always start and operate the engine in a well ventilated area.
- If in an enclosed area, vent the exhaust to the outside.
- Do not modify or tamper with the exhaust system.

WARNINGS



WARNING

A fully charged dry chemical type fire extinguisher must be within easy reach whenever the burners are operating or there is an open flame near the Distributor. The minimum capacity of the fire extinguisher should be 10 pounds.

Fluoroelastomer Handling

Some O-rings and seals used in this vehicle are made from fluoroelastomers. When used under design conditions, fluoroelastomers do not require special handling. However, when fluoroelastomers are heated to temperatures beyond their design temperature (around 600° Fahrenheit), decomposition may occur with the formation of hydrofluoric acid. Hydrofluoric acid can be extremely corrosive to human tissue if not handled properly.

A degraded seal may appear as a charred or black sticky mass. Do not touch either the seal or the surrounding equipment without wearing neoprene or PVC gloves if degradation is suspected. Wash parts and equipment with 10% lime water (calcium hydroxide solution) to neutralize any hydrofluoric acid.

If contact with the skin occurs, wash the affected areas immediately with water. Then rub a 2.5 calcium gluconate gel into the skin until there is no further irritation, while seeking prompt medical attention.

Note to Physicians: For advice or treatment of HF burns, call the DuPont Medical Emergency number, 1-800-441-3637.

To prevent an explosion or fire hazard:

- Position the unit broadside to the wind to prevent volatile fumes from drifting toward the burners.
- Do not operate the burners if the tank is damaged or leaking.
- Ensure that the burners are extinguished before removing any material from the tank in any manner. Liquid petroleum (LP) burners can support a flame for several minutes after the fuel supply is turned off.

To prevent an explosion or fire hazard:

- Do not operate the burners when the vehicle is unattended, when the vehicle is in motion, or with the vehicle in a confined area.
- When the burners go out, shut off the fuel supply to both burners and allow the flues to ventilate for at least 3 minutes before re-lighting the burners.
- Do not heat the material beyond the manufacturer's recommended temperature.
- Keep burning cigarettes or other sources of combustion away from manholes and overflow vents.
- Keep area free of all sources of combustion when spraying.
- Check the tank vent to insure that it is free from obstruction before lighting the burners.
- Eliminate sparks from engine exhaust.
- Do not operate the burners with the manhole open or open the manhole while the burners are in operation.
- Flues must be covered by a minimum 6 inches of material (bitumen) when burners are in operation.

To prevent possible hand or facial burns:

- Always light the inside burner first. Do not reach across a lit burner to light or re-light the inside burner. Shut off the outside burner before lighting the inside burner.

To prevent possible burns:

- Always use a torch to light the burners. Never attempt to light the burners using a match or pocket lighter.
- Always wear insulated gloves when handling spray bar sections or hoses.
- Always wear eye protection, face shield, long sleeve shirt, insulated gloves, boots, and long pants outside the boots when working around the Distributor.
- Use extreme caution when using a torch to heat the pump. Asphalt accumulated around the pump may ignite when heating the pump with a torch.

⚠ WARNINGS

To prevent possible burns from leaking material:

- Be sure all pipe, cap and hose connections are secure before opening valves, or beginning any operation.

To prevent possible burns from hot asphalt spray:

- Do not stand, or allow anyone to stand, where accidental opening of a valve may cause contact with hot asphalt.

To prevent possible burns from foaming or violent eruption:

- Do not load tank with material temperature over 200°F if water or condensation is present in tank, or if emulsion was used in the previous load.
- Do not heat material over 200 °F if moisture or emulsified material is present in tank.

To prevent burns from hot asphalt when hand spraying:

- Hold the handspray gun in proper position and watch for other people.

To prevent possible burns to operators or bystanders, or possible equipment damage:

- Do not start any operation if any control settings are unknown.

To prevent severe injury from becoming entangled in machinery:

- Stand clear of rotating drives.

To prevent possible injury:

- Always open the manhole cover slowly. Pressure build up in the tank may cause the cover to burst open.

To prevent possible fire hazards, burns or falls:

- Keep the unit clean for safe operation.

To prevent possible burns from material overflow:

- Allow sufficient space in the tank for expansion of the material when heating
- Before removing the fill line cap, make certain that the asphalt pump is turning and the tank valve is closed.

⚠ WARNING

To prevent possible personal injury:

- Do not load the vehicle beyond the GAWR or GVWR. The maximum load volume must be calculated based on material density.

Allowing the burners to operate for a long period of time without circulating can damage the product and create explosive fumes. If product cannot be circulated after fifteen minutes of heating without circulation, the burners should be extinguished for 20 - 30 minutes before re-lighting the burners.

⚠ WARNING

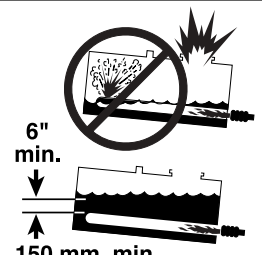

6" min.
150 mm. min.

Do not light burners unless flues are covered. Explosion can occur causing death or serious injury.

Lower Burner
Lit. Gal.

Upper Burner
Lit. Gal.

3390636

⚠ WARNING

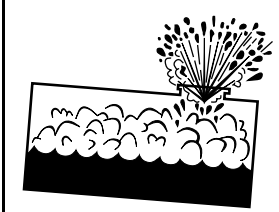

Do not change asphalt grades without reading operators manual. Explosion can occur causing death or serious injury.

3390637

Use the measuring stick as shown in Figure 9 in the *Using the Measuring Stick* section to determine the amount of product in the tank before lighting burners. The minimum amounts shown on the warning placard only apply if the tank is level.

Remember that the measuring stick is accurate only when the tank is level. If the tank is not level, reposition the Distributor to place the tank in a level position before taking final measurement. You must have at least the amounts shown, with the tank level, in order to safely light the lower burner and upper burner respectively. **Failure to have the appropriate amount, accurately measured can result in an explosion causing death or serious injury.**

Foaming



WARNING

To prevent possible burns from foaming or violent eruption:

- Do not load tank with material temperature over 200 °F if water or condensation is present in tank, or if emulsion was used in the previous load.
- Do not heat material over 200 °F if moisture or emulsified material is present in tank.

If the Distributor is to be filled with hot bitumen, proceed very cautiously. If there is any moisture in the tank, or if an emulsion product was the last load, foaming or eruption may occur.

Dow-Corning DC-200 may be used to prevent foaming in Distributors, Transports, and Maintenance Units.

Mix the contents of one can (16 oz.) with one (1) gallon of diesel fuel or kerosene. Add one (1) oz. of this diluted mixture to each 1000 gallons of asphalt. The correct amount may be poured through the manhole. This will assist in reducing foaming, particularly if moisture is present or if an emulsified asphalt was used in a previous load.

If foaming does not occur at the start of the loading operation, but you suspect that there may be moisture in the spray bar or circulating system, the loading operation should be stopped when the tank is no more than 25% full. The product should then be circulated through the spray bar at a rate of 80 to 100 GPM before continuing the loading operation.

If foaming does occur, continue circulating until the foaming stops, and then suck back the product in the spray bar back into the tank before filling the tank the rest of the way.

Asphalt Institute

To further increase awareness of the hazards associated with the operation of a bituminous distributor, and before beginning initial operation, the operator should also receive instruction by an authorized Etnyre dealer, or Etnyre representative.

The Centennial Distributor is designed to handle a number of different products, such as ACs, cutbacks & emulsions.

Knowledge of these liquid asphalts is required for safe operation of the Distributor. It is critical to know which product can be loaded after the previous product, and which products react with each other.

The Asphalt Institute is a source of asphalt handling safety information.

Asphalt Institute
Research Park Drive
PO Box 140052
Lexington, KY 40512-4052
606-288-4960

Introduction

Your Etnyre Blacktopper Centennial Distributor is designed to give you many years of accurate, dependable, and economic service. The following instructions will enable you to receive the maximum performance from your Blacktopper Centennial Distributor.

The Blacktopper Centennial Distributor's controls are designed for simple operation. They require a minimum of training for proficient usage. The exclusive Etnyre circulating system is designed and built for handling all grades of bituminous materials efficiently.

This manual is provided as a tool to aid personnel in the operation of the Etnyre Blacktopper Centennial Distributor in a safe and efficient manner. As with any type of construction equipment, there are certain hazards associated with improper or careless operation. The ability to read and understand the instructions in this manual should be a required qualification to become an operator. There are also functions that require a certain amount of physical strength to accomplish. Persons lacking the required strength may not only place themselves in jeopardy, but also others in the vicinity.

This manual covers standard features and options for truck mounted units with computerized controllers only. If your unit is equipped with Basic Controls, please refer to Operation manual number M-102-99 or later. If your unit incorporates custom features, some of the information contained in this manual may not apply. If you have any questions regarding this manual or your unit, contact your Etnyre dealer or the E. D. Etnyre Service Department at 1-800-995-2116.

Reporting Safety Defects

If you believe that your vehicle has a defect which could cause a crash, or could cause injury or death, you should immediately inform the National Highway Traffic Safety Administration (NHTSA) in addition to notifying E. D. Etnyre & Co.

If NHTSA receives similar complaints, it may open an investigation; and, if it finds that a safety defect exists in a group of vehicles, it may order a recall and remedy campaign. However, NHTSA cannot become involved in individual problems between you, your dealer, or E. D. Etnyre & Co.

To contact NHTSA, you may either call the Auto Safety Hotline toll free at 1-800-424-9393 (or 336-0123 in the Washington, D.C. area) or write to NHTSA, U.S. Department of Transportation, Washington, DC, 20696. You can also obtain other information about motor vehicle safety from the hotline.



CAUTION

Unusually strong electromagnetic interference could cause the electronic controls on this equipment to temporarily malfunction. Test the effect of two way radios and similar equipment while operating in a safe area.

Component Location And Identification

Rear and Side Components

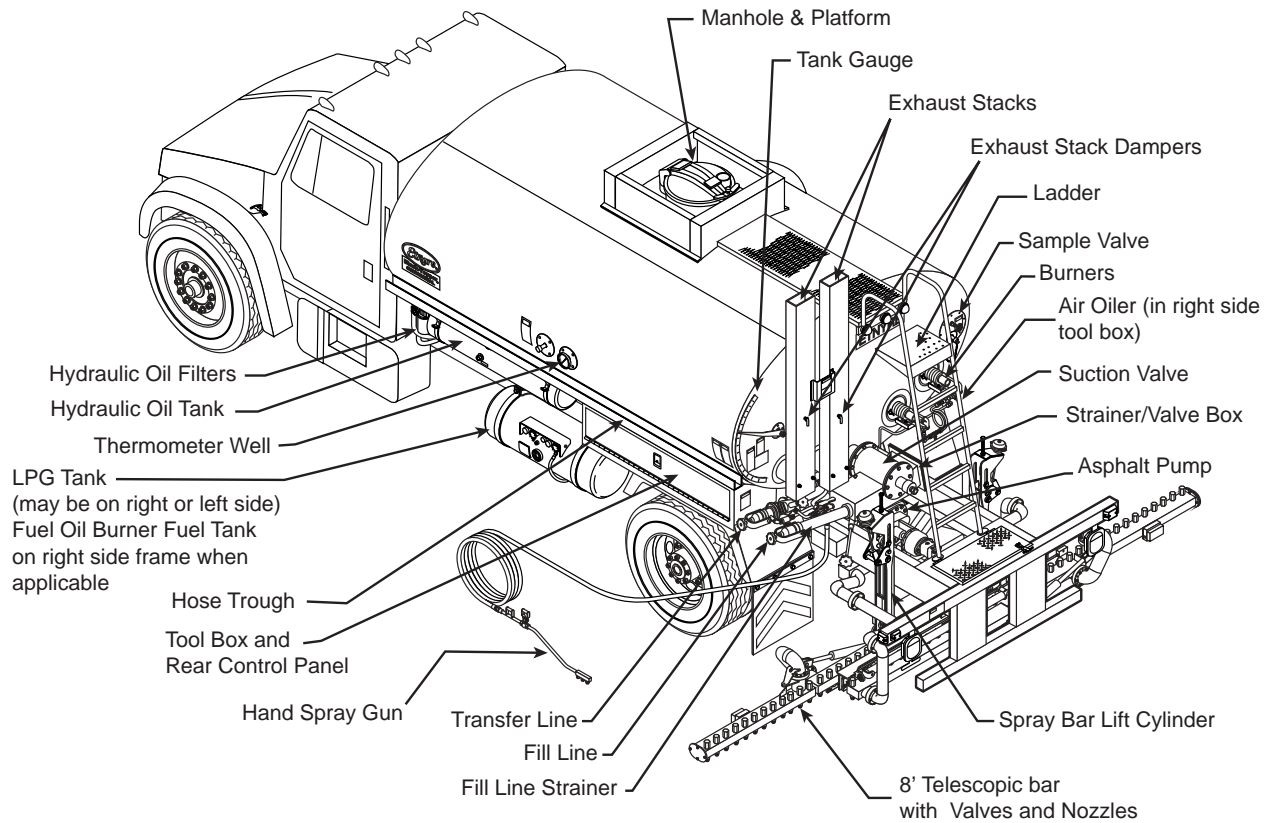

Figure 2. Rear and Side Component Identification.

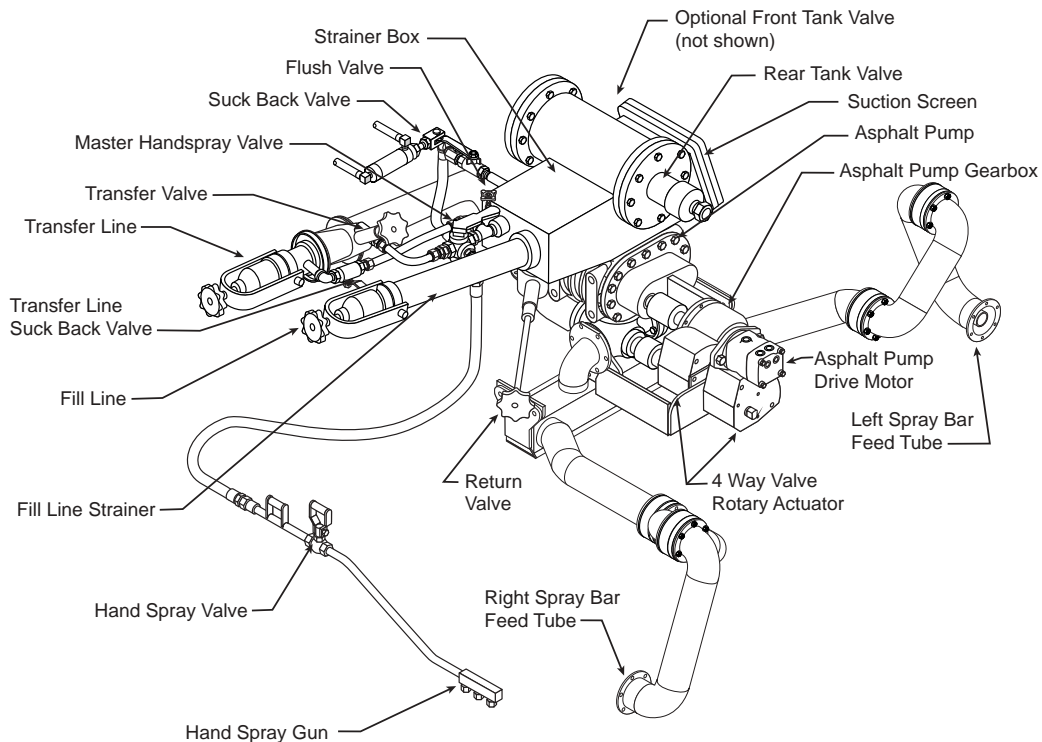

Figure 3. Rear Component Identification.

Spray Bar Components

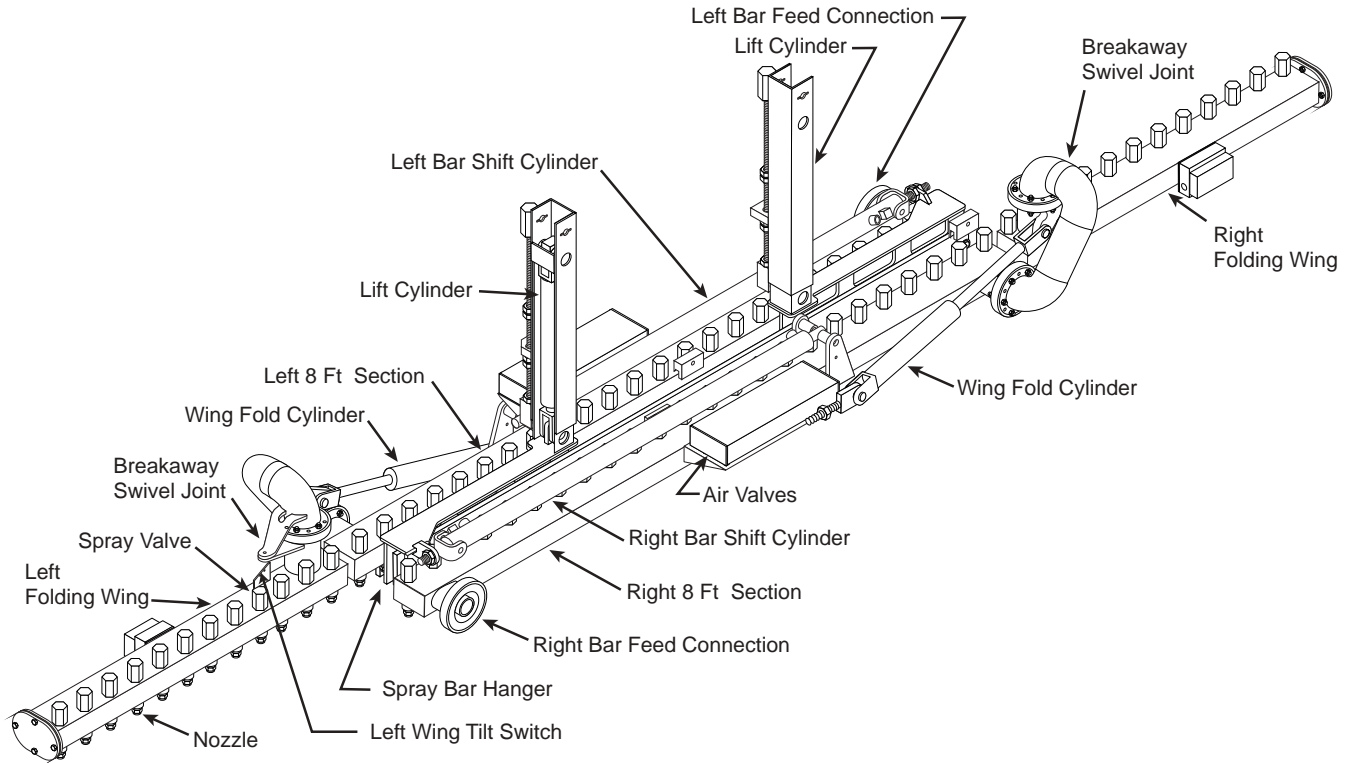

Figure 4. Spray Bar Component Identification.

Hydraulic Tank Components

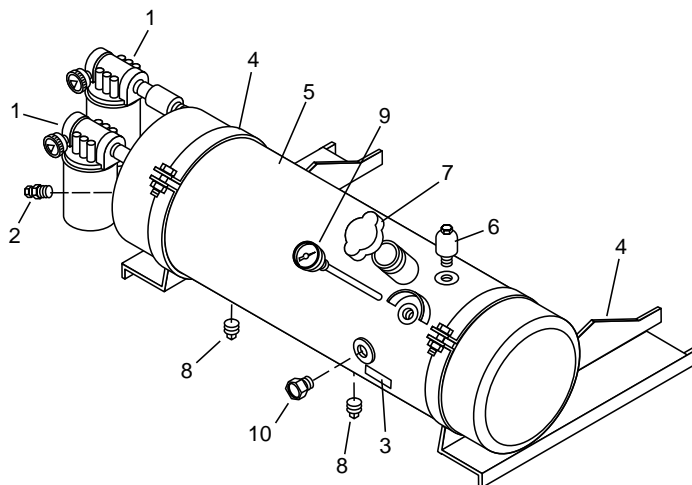

Figure 5. Hydraulic Tank Component Identification.

Cab Control Panel

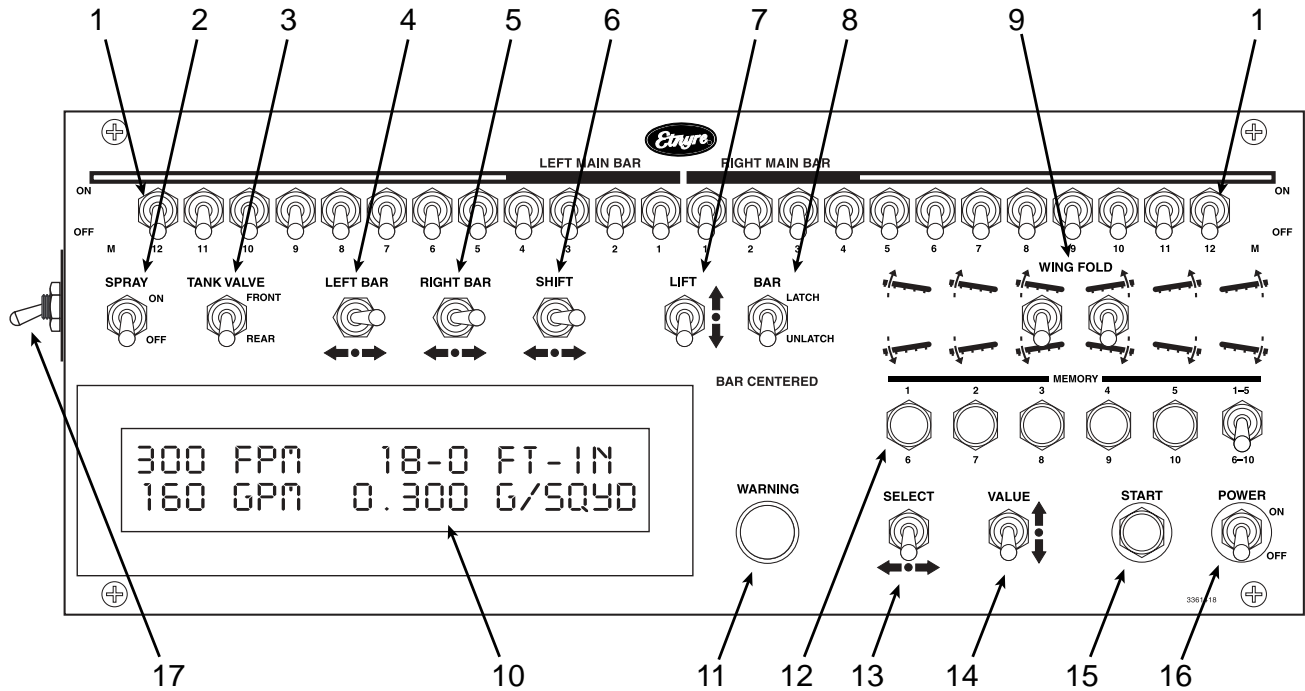

Figure 6. Cab Control Panel Components.

Cab Control Panel Descriptions

1. One Foot Switches

These switches activate a corresponding foot of spray bar valves, there are three spray valves per foot of spray bar. Switch and spray valve numbering starts from the center of the Distributor and goes outward in each direction. On variable width spray bars the spray valves associated with switch 1 are only in the center of the Distributor when the spray bar is fully extended. From the fully retracted position, spray valves associated with switch 4 are the first to be turned ON, with switch 4 ON, as the spray bar is extended. One Foot switches that are on a wing, which is raised, or in the retracted portion of a variable width spray bar do not add to the displayed spray width even if they are turned ON.

The activated, switch ON, foot of spray bar will come *on* when the SPRAY switch is turned ON. The computer will automatically change the pumping rate as spray valves are turned on or off while spraying to compensate for the number of feet being sprayed.

2. MASTER SPRAY Switch

Turning this switch to ON when the Function knob (rear panel) is turned to BAR CIRCULATE or BAR SUCK BACK, opens all activated spray valves. The spray valves are allowed to open in BAR SUCK BACK for troubleshooting. Turning the SPRAY switch ON the LOAD/TRANSFER or TANK CIRCULATE positions of the Function knob allows the accumulated values to increment for measuring.

3. TANK VALVE Switch

Selects between the standard REAR tank valve and the optional FRONT tank valve. FRONT should always be selected prior to spraying to eliminate air in the load line. FRONT can then be selected at anytime while spraying.

4. LEFT BAR Switch

Extends or retracts the left variable width spray bar. Holding the switch in either direction moves the spray bar continuously until the switch is released or until the spray bar is fully extended or retracted. A single press of the switch in either direction moves the spray bar 4 inches until it is fully extend or retracted. If the spray bar, due to shifting, does not fully extend or retract, holding the switch in the desired direction for 5 seconds forces the spray bar into position.

5. RIGHT BAR Switch

Extends or retracts the right variable width spray bar. Holding the switch in either direction moves the spray bar continuously until the switch is released or until the spray bar is fully extended or retracted. A single press of the switch in either direction moves the spray bar 4 inches until it is fully extend or retracted. If the spray bar, due to shifting, does not fully extend or retract, holding the switch in the desired direction for 5 seconds forces the spray bar into position.

6. SHIFT Switch

Moves the entire spray bar left or right. Holding the switch in either direction moves the spray bar continuously until the switch is released, or until full right or left is obtained.

7. LIFT Switch

The bar latching position is when the spray bar is completely raised. Unlatch the spray bar (BAR switch) before lowering it. The spray bar may need to be raised to allow the bar latching mechanism to move. The spray bar cannot be lowered beyond the height adjuster setting, which is set for a spray height of 12 inches at the factory. The height adapters may be adjusted higher or lower for individual preference. Also see the *Adjusting Spray Bar Height* section.

8. BAR Latch Switch

Put the switch in the LATCH position for transporting or in the UNLATCH position for spraying. The bar latching mechanism remains in the selected position even though the switch does not.

9. WING FOLD Switches

Spray bars have fixed center sections and folding wings on both sides. Spray bars that have the corresponding One Foot switches turned ON will increase the spray width when the wing is lowered and decrease the spray width when raised beyond the wing tilt switch setting. It is always a good practice to turn OFF the corresponding One Foot switches before raising the wing while spraying.

10. Display

All information critical for Distributor operation is displayed on this two-line LCD. When the system is turned ON, the installed software version is displayed for a few seconds, after which the first of three operating screens is displayed. Eight additional screens are used for setting up the computer. Warning messages flash over the entire display to communicate critical information.

Refer to the *Setting up the Computer* and *Operation Screens* sections in this manual for more information.

11. WARNING Light

Indicates that there is critical information to be viewed on the Display.

12. MEMORY Switches

Store and recall up to ten preset application rates for quick selection. To store the desired application rate, make the application rate the selected value on the display then press and hold the desired Memory button while selecting the desired application rate with the VALUE switch. Each button has a factory preset between 0.050 and 0.500 G/SQYD, or the Metric equivalent. Memories 1-5 are available when the Memory expander switch is set to 1-5 and similarly, memories 6-10 are available when the Memory expander switch is set to 6-10.

13. SELECT Switch

Navigate through the display using the SELECT switch. The selected position on the screen is identified by the flashing value. The display reads like a book, right moves right and down while left moves left and up.

14. VALUE Switch

The selected value, identified by the flashing, can be changed using this switch. Most values can be increased or decreased by holding the switch in the desired direction for large changes. The accumulated values on the second operating screen can be reset to zero by first selecting the desired value and then selecting VALUE decrease. Length and area reset together when either is selected before selecting VALUE decrease.

15. START Button

Starts the asphalt pump turning at the target pump rate, used also for calibration operations in the setup screens. When the Function knob (rear panel) is turned to BAR CIRCULATE, the displayed spray width must be greater than zero for the pump to start turning when the START button is pressed.

16. Power Switch

Both POWER switches, front and rear, must be ON for the system to be ON. The entire system can be shut down by turning either POWER switch to OFF. Before turning either POWER switch to ON be sure you know what will automatically activate.

17. SUCK BACK OVERRIDE Switch

When ON, this switch overrides the current setting of the Function knob in the rear panel to the SUCK BACK selection. The SUCK BACK OVERRIDE must be OFF for the Function knob to work correctly.

Low Tank Level Indicator

A message on the display indicates low material level in the tank.

Components Not Shown

The following components are not on the Cab Control Panel but may be mounted below the panel or on the vehicle's dash. Such as hour meter, mirror switch(s), beacon, strobe, PTO light.

Rear Control Panel

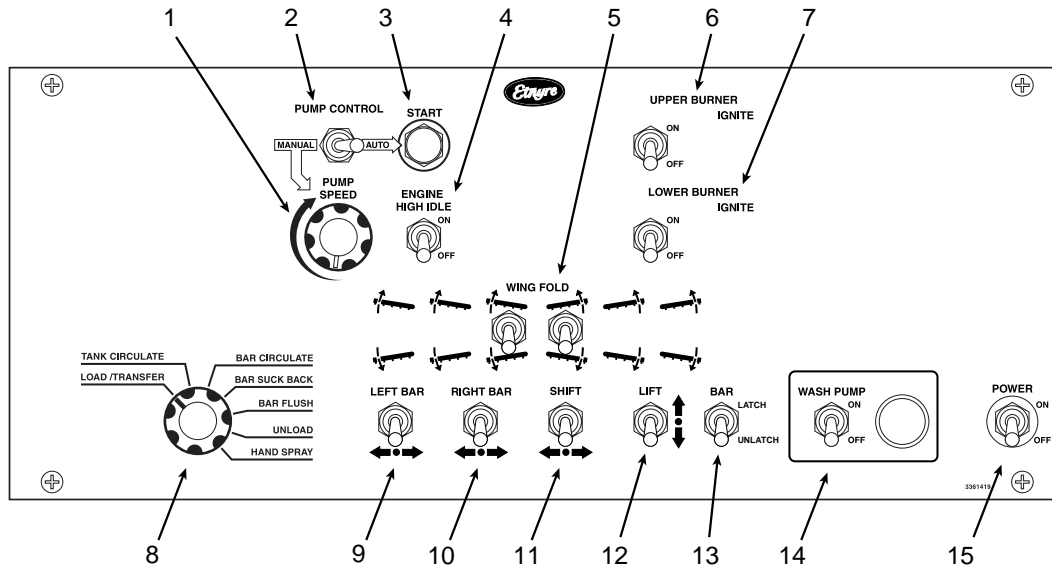

Figure 7. Rear Control Panel Components.

Rear Control Panel Descriptions

1. PUMP SPEED Control Knob

When MANUAL PUMP CONTROL is selected, turning this knob to the right (clockwise) increases the asphalt pump speed. It is possible to over-speed the asphalt pump in MANUAL control since the asphalt pump speed is also dependent on the engine speed. Always turn the knob back to the left (counter-clockwise) before selecting AUTO PUMP CONTROL or turning ON either POWER switches (front or rear).

2. PUMP CONTROL Switch

With the switch turned to AUTO, the asphalt pump speed is controlled at the desired rate through the computer which limits the maximum pump speed to 450 GPM. When the Function knob is set to BAR CIRCULATE, the pump speed is limited to a maximum of 120 GPM. With the switch turned to MANUAL, the asphalt pump speed is controlled with the PUMP SPEED control knob.

In AUTO control, **START** flashes over the target pump rate until the START button is pressed. In MANUAL control, **MAN** flashes over the pump rate as a reminder that PUMP CONTROL is not in AUTO. Use Etnyre computer (p/n 3390408) when spraying in MANUAL control.

3. START Button

Starts the asphalt pump turning at the target pump rate, used also for entering the setup

screens and also for calibration operations in the setup screens. When the Function knob is turned to BAR CIRCULATE, the displayed spray width must be greater than zero for the pump to start turning when the START button is pressed.

4. ENGINE HIGH IDLE Switch

When this option is available and installed, turning ON this switch makes the engine run at a higher RPM. Turning OFF the switch resumes the engine speed to idle. The high idle setting varies but can be programmed to your preference through your truck dealer. This switch is not disabled through the POWER switch.

5. Wing Fold Switches

Spray bars have fixed center sections and folding wings on both right and left sides. Spray bars that have the corresponding One Foot switches turned ON will increase the spray width when the wing is lowered and decrease the spray width when raised beyond the wing tilt switch setting. It is always a good practice to turn OFF the corresponding One Foot switches before raising the wing while spraying.

6. LOWER BURNER Switch

When an optional fuel oil burner is installed, this switch directly controls the lower burner unless an optional thermostatic control or brake interlock switch is also installed. Then it is possible for the switch to be ON when the burner is off. Before operating the burner, refer to the *Burner Operation* section in this manual.

7. UPPER BURNER Switch

When an optional fuel oil burner is installed, this switch directly controls the upper burner unless an optional thermostatic control or brake interlock switch is also installed. Then it is possible for the switch to be ON when the burner is off. Before operating the burner, refer to the *Burner Operation* section in this manual.

8. Function knob

When the desired operation is selected through this knob, the asphalt pump stops turning if the PUMP CONTROL is in AUTO, all automatic valves (tank valve, 4-way valve, bar suck back valves, and balance valves) are set for the desired operation, and the stored asphalt pump rate target preset for the desired operation is recalled. When BAR CIRCULATE is selected, the asphalt pump rate target is calculated based on the displayed spray width, application rate, and the setting of the %CIRC factor. A %CIRC setting of 50% is equivalent to a spray pump rate while traveling at 150 FPM. For all positions of this switch, except BAR CIRCULATE, the asphalt pump rate preset can be set to operator preference by first selecting AUTO PUMP CONTROL. Then before pressing the START button, change the pump rate target to the desired rate and then press the START button to save the desired rate and start the pump turning.

The factory pump rate target presets are (With Metric equivalents also):

- LOAD/TRANSFER 100 GPM
- TANK CIRCULATE 150 GPM
- BAR SUCK BACK 200 GPM
- BAR FLUSH 100 GPM
- UNLOAD 100 GPM
- HAND SPRAY 50 GPM

9. LEFT BAR Switch

Extends or retracts the left variable width spray bar. Holding the switch in either direction moves the spray bar continuously until the switch is released or until the spray bar is fully extended or retracted. A single press of the switch in either direction moves the spray bar 4 inches until it is fully extend or retracted. If the spray bar, due to shifting, does not fully extend or retract, holding the switch in the desired direction for 5 seconds forces the spray bar into position.

10. RIGHT BAR Switch

Extends or retracts the left variable width spray bar. Holding the switch in either direction moves the spray bar continuously until the switch is released or until the spray bar is fully extended or retracted. A single press of the switch in either direction moves the spray bar 4 inches until it is fully extend or retracted. If the spray bar, due to shifting, does not fully extend or retract, holding the switch in the desired direction for 5 seconds forces the spray bar into position.

11. SHIFT Switch

Moves the entire spray bar left or right. Holding the switch in either direction moves the spray bar continuously until the switch is released, or until full right or left is obtained.

12. LIFT Switch

The bar latching position is when the spray bar is completely raised. Unlatch the spray bar (BAR switch) before lowering it. The spray bar may need to be raised to allow the bar latching mechanism to move. The spray bar cannot be lowered beyond the height adjuster setting, which is set for a spray height of 12 inches at the factory. The height adjusters may be adjusted higher or lower for individual preference. Also see the *Adjusting Spray Bar Height* section.

13. BAR Latch Switch

Raise the bar before latching. Put the switch in the LATCH position for transporting or in the UNLATCH position for spraying. The bar latching mechanism remains in the selected position even though the switch does not.

14. WASH PUMP Switch and Light

When the optional solvent pump and switch is installed turning the switch ON will allow use of the solvent wash wand or application of solvent to the top of the asphalt pump without the pump turning. The light is a reminder that the switch and pump are ON.

15. Power Switch

Both POWER switches, front and rear, must be ON for the system to be ON. The entire system can be shut down by turning either POWER switch to OFF. Before turning either POWER switch to ON be sure you know what will automatically activate.

Preparing for Operation

Note: Always refer to the truck chassis owner's manual for chassis and engine maintenance information.

The following procedures apply to new or rebuilt units.

1. Inspect the unit for damage that may have occurred during transporting.
2. Check and tighten all fasteners, body tie-down bolts, pipe and circulating line connections, etc. that may have loosened in transit.
3. Check the fluid level in the hydraulic reservoir. The fluid must always be visible in the sight glass.



WARNING

To prevent possible personal injury, do not load the vehicle beyond the GAWR or GVWR. The maximum load volume must be calculated based on material density.

Setting Up the Computer

Before the Distributor is used, the control computer has to be set for each particular Distributor. There are seven setup screens used to set parameters and perform calibrations for the Distributor that the control computer is installed in. Setup is performed for the customer at the factory and should not need to be changed except for when major service or repair is performed on the Distributor.

To enter the set up screens hold Memory 6 and 10 buttons down while turning the POWER switch to ON. Then release the buttons. To exit the setup, turn the power OFF. Any changes that are made while in the setup screens are automatically saved.

The SELECT switch is used to navigate through the Setup screens, while the VALUE switch is used to change the value that is selected. The START switch is used to initiate calibration procedures in the Setup screens. Abbreviated instructions for the calibration procedures are displayed for quick recall.

First Screen

```
UNITS = ENGLISH  
BAR CONTROL = VW
```

This screen allows you to set the display units and bar control. VALUE increase from English to get Metric. VALUE increase from FOOT to get GANG or decrease from FOOT to get VW (variable width).

Second Screen

```
FLOW FACTOR = 1000  
SPRAY DELAY = 0.20
```

This screen is used to set the flow factor and spray delay. The flow factor is the calibration factor for the asphalt pump. Changing the value from 1000 (100%) does not change the pump flow but does change the displayed pump rate. Values greater than 1000 increase the displayed pump rate while values less than 1000 decrease the displayed pump rate. The flow factor increments or decrements by 0.1% and should only be changed when you are absolutely sure that such a correction needs to be made.

The spray delay is the amount of time, in seconds, between the computer powering the 4-way valve from bar circulate to spray and powering the spray bar valves open. Physical delays within the mechanical controls of these valves may have significantly changed and should be addressed before making significant deviations from 0.20 seconds.

Third Screen

```
MOTOR PUL/REV = 43
PUMP PUL/REV = 47
```

The third setup screen allows for selection of the hydraulic motor and hydraulic pump speed sensor pulses per revolution. The correct settings of each are dependent upon displacement. Holding the VALUE switch will not continuously increment or decrement either value. Two values are valid for the motor: 43 for 1.53 cubic inches per revolution (CIR) motor, and 46 for both 2.1 and 2.69 CIR motors.

Three values are valid for the pump: 47 for 2.1 CIR pumps, 58 for 4.57 CIR pumps, and 63 for 6.1 CIR pumps.

Fourth Screen

```
VWVB LEFT FOBK = 0
START - FULL EXT/RET BAR
```

The fourth setup screen allows for calibration of the left VW spray bar. The instructions for calibration are abbreviated on the display. Press START, extend the left spray bar completely, retract the left spray bar completely, and finally press the START button again. The feedback number on the display should increase as the spray bar extends and decreases as the spray bar retracts. When fully extended the feedback value should be 99 or 100, after which the fully retracted value should be 0. Recalibration from the factory calibration should not be required except when the smart cylinder or wiring to the smart cylinder has been replaced.

Fifth Screen

```
VWVB RIGHT FOBK = 0
START - FULL EXT/RET BAR
```

The fifth setup screen allows for calibration of the right VW spray bar on. The instructions for calibration are abbreviated on the display. Press START, extend the right spray bar completely, retract the right spray bar completely, and finally press the START button again. The feedback number on the display should increase as the spray bar extends and decreases as the spray

bar retracts. When fully extended the feedback value should be 99 or 100, after which the fully retracted value should be 0. Recalibration from the factory calibration should not be required except when the smart cylinder or wiring to the smart cylinder has been replaced.

Sixth Screen

```
GROUND SPEED CAL
START AT 300FT BEGIN
```

This screen allows for ground speed calibration. The ground speed is calibrated at the factory through the proper angle and height settings of the radar. Ground speeds that are displayed when the Distributor is parked are most likely due to engine vibrations through the truck frame or reflections off surfaces, such as water. Standing water present while spraying may give incorrect ground speeds. The instructions for calibration are abbreviated on the display.

First mark out a smooth, dry, flat, straight 300 foot path. While driving the Distributor at a constant speed of approximately 300 FPM press START when a fixed point on the truck crosses the first line. Then press the START button again when the same fixed point on the truck crosses the second line. Once the START button is pressed the first time, **BEGIN** on the screen changes to **END** and will change back to **BEGIN** when pressed the second time.

Seventh Screen

```
EDC THRESHOLD=15.0mA
```

This screen allows for setting the hydraulic pump EDC threshold in milliamps. The threshold is the minimum required electrical current for the asphalt pump to turn. The threshold is optimally determined at a hydraulic pump speed of 1200 RPM. Threshold settings lower than actual produce instability in the pump control while settings higher than actual do not allow the asphalt pump to be controlled at the lowest speed possible.

Engaging Pump on PTO Equipped Distributors

Start the truck engine. Then, follow one of the procedures below.

Ensure that the truck parking brake is engaged before leaving the cab.

Manual Transmissions

Depress the clutch and pull outward or upward on the PTO control knob. Slowly let the clutch up. If the PTO fails to engage, depress the clutch pedal and pull up on the PTO handle until engagement occurs. Or, depress the electric air shift PTO switch if your vehicle is so equipped. Increase the engine rpm to a fast idle.

Automatic Transmissions

Push down on the foot brake pedal, move the gear selector to any forward gear and do one of the following.

- Pull upward or outward on the PTO control knob.
- Press the switch activated PTO switch.
- Press the electric air shift PTO switch if your vehicle is so equipped. When the PTO engages, move the gear selector to neutral. If the PTO fails to engage, release the brake pedal slightly while pressing the PTO switch, allowing the truck to inch forward until the PTO engages. Then move the gear selector back to neutral.

WARNING

To prevent an explosion or fire hazard, do not heat the material beyond the manufacturer's recommended temperature.

WARNING

To prevent possible burns to operators or bystanders, or possible equipment damage, do not start any operation if any control settings are unknown.

WARNING

To prevent severe injury from becoming entangled in machinery, stand clear of rotating drives.

CAUTION

To prevent possible damage to equipment from material setting up in hose or Distributor, ensure that bitumen in supply tank is heated sufficiently.

Spraying Operations

A correct spray pattern cannot be obtained unless the product is heated to its proper spraying temperature. Cold product will not provide sharp spray edges, and will cause streaking. If heating of the product is required, refer to the section of this manual on *Heating Product in Distributors* for instruction on operation of your particular type of burners.

The computer automatically adjusts the asphalt pump speed to deliver the correct amount of asphalt for the application rate, spray width and vehicle speed. The circulation rate in the bar when not spraying should be set to 50% of the pump speed while spraying. This circulation rate will allow the asphalt pump to reach the desired speed quickly when spraying is started. Circulation rates higher than 50% will result in a heavier start while rates below 50% will produce a lighter start.

Spray bar nozzles have a limited flow range at which optimal performance will be achieved. Flow rates greater than this optimal range will cause excessive overspray. Rates that are too low will cause the fan to sag and cause heavy edges. Refer to the nozzle selection chart in the operator's manual to select the nozzles appropriate for your conditions.

WARNING

To prevent an explosion or fire hazard, ensure that the burners are extinguished before removing any material from the tank in any manner. Liquid petroleum (LP) burners can support a flame for several minutes after the fuel supply is turned off.

WARNING

To prevent an explosion, do not operate the burners when the vehicle is unattended, when the vehicle is in motion, or with the vehicle in a confined area.

WARNING

To prevent an explosion or fire hazard, when the burners go out, shut off the fuel supply to both burners and allow the flues to ventilate for at least 3 minutes before re-lighting the burners.

WARNING

To prevent an explosion or fire hazard, do not heat the material beyond the manufacturer's recommended temperature.

WARNING

To prevent an explosion or fire hazard, keep burning cigarettes or other sources of combustion away from manholes and overflow vents.

WARNING

To prevent possible hand or facial burns, always light the inside burner first. Do not reach across a lit burner to light or re-light the inside burner. Shut off the outside burner before lighting the inside burner.

WARNING

To prevent possible burns from material overflow, allow sufficient space in the tank for expansion of the material when heating.

WARNING

To prevent possible burns to operators or bystanders, or possible equipment damage, do not start any operation if any control settings are unknown.

WARNING

To prevent possible burns from leaking material, be sure all pipe, cap and hose connections are secure before opening valves.

WARNING

To prevent possible burns from hot asphalt spray, do not stand, or allow anyone to stand, where accidental opening of a valve may cause contact with hot asphalt.

Setting the Digital Memory Presets

Setting the digital memory presets is not required to spray. The memory buttons offer the operator a convenient way to store 10 different preset application rates. These settings are saved in the memory even after the power switch has been shut off.

To store an application rate in a memory location, select GAL/SQ YD in the digital display using the SELECT switch.

To set a memory, push that preset button in and hold it. While holding it in, set the application rate to the desired value using the VALUE switch. To raise the application rate hold the VALUE switch up and to lower the application rate, hold the VALUE switch down. When you have the application rate set to the desired value, release the memory button. The displayed application rate will be stored in that memory location until it is over-written with a new application rate using the same procedure.

Adjusting the Spray Bar Nozzle Angle

Adjust the nozzles to obtain an angle of approximately 30 degrees with the spraybar center line. Every nozzle should be at the same angle. A nozzle adjustment wrench is supplied with each new unit.

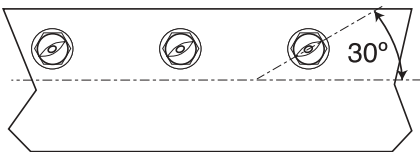

Figure 8. Adjusting the Spray Bar Nozzles.

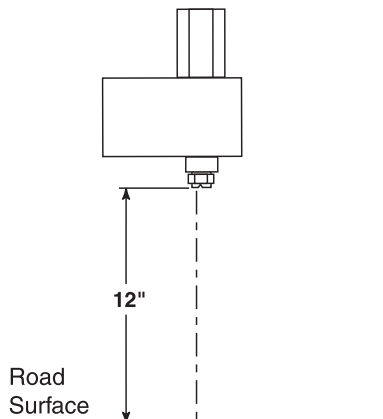

Figure 9. Adjusting the Spray Bar Height.

Adjusting the Spray Bar Height

Lower the spraybar and adjust the height adjusters so that the nozzles are approximately 12 inches above the road, on the main bar with both wings folded, when the tank is empty. At this height, the spray fans from the nozzles will overlap to provide triple lap coverage of material on the ground. This is the normal spraying height. Lower the wings and adjust them with the cylinder nuts to follow the crown of the road.

Spraying through the Bar

A tack coat selector valve on the air oiler assembly allows you to select between truck pressure and 20 psi. The lower regulator should be set to 20 psi. When Tack Coat is selected, the top side of every other spray valve has truck pressure applied, which overcomes the truck pressure applied to the underside of the spray valve because of the difference in areas and the additional spring on the top side. In Normal Spray, all spray valves have 20 psi on the top side. Be sure that this valve is selected correctly before continuing.

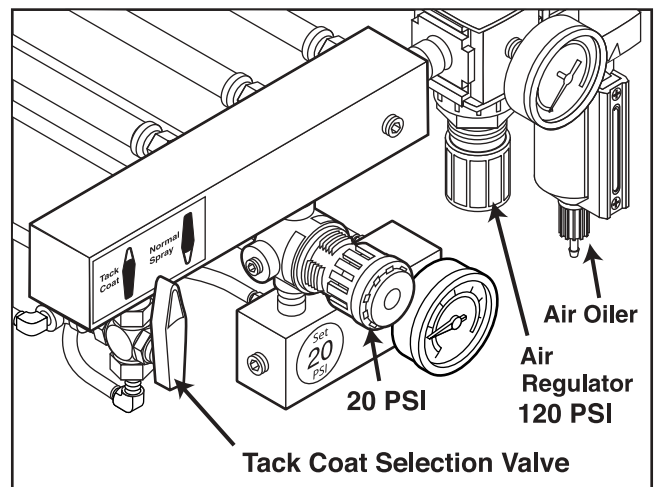

Figure 10. Selector Valve set to Normal Spraying.

If you are stopped and shut the spray bar off, the computer will shut the spray bar off within a few seconds so that asphalt doesn't puddle, but you will not get a straight line.

Operation

Tank Capacity

The Centennial Distributor is designed to pump and spray a variety of asphalt products in an efficient and user friendly manner with great accuracy. The Centennial Distributor utilizes a computer to sense the vehicle's ground speed and control the hydrostatically driven asphalt pump to maintain the set application rate, regardless of variations in vehicle speed or spray bar width in use.

For a complete description of each of the controls and how to set up the machine, refer to the *Preparing for Operation* section of this manual.



WARNING

To prevent possible personal injury, do not load the vehicle beyond the GAWR or GVWR. The maximum load volume must be calculated based on material density.

The Centennial Distributor tank has a built-in air space, or expansion space, above the *Tank Full* level. This air space is designed to minimize the chance that the tank will overflow if the material in the tank expands due to heating or foaming. This air space should not be used to carry product. The *Tank Full* level is based on the vehicle's axle ratings, and, GVWR at a material density of 7.7 lbs/gallon. A lower *tank full* must be calculated if a product with a density greater than 7.7 lbs/gallon is to be loaded. The lower *tank full* is calculated by multiplying the original *tank full* by 7.7 and dividing the result by the new heavier product density.

If you suspect there may be moisture or emulsion in the tank, Dow-Corning™ DC-200 additive can be used to reduce foaming if a product being pumped is at a temperature in excess of 200 °F. Additional DC-200 additive may be obtained from E. D. Etnyre & Co. or your Etnyre dealer.

Operation Screens

The following are the the three screens on the Cab Control Panel that are used during normal operation. Use the SELECT switch to scroll through the functions and the VALUE switch to increase or decrease the selected value, when appropriate. Use the SELECT switch to advance to the next screen.

When the system is turned ON the installed software version is displayed for a few seconds, after which the first operating screen is displayed.

```
ETNYRE  
VERSION 3.3
```

First Operating Screen

```
0 FPM      0-0 FT-IN  
200 GPM    0.005 G/SQYD
```

The first operating screen displays ground speed, spray width, asphalt pump speed, and application rate. The application rate is automatically the first selected and flashing value. **START** or **MAN** will also flash over the pump rate. When PUMP CONTROL is in AUTO, **START** will stop flashing after pushing the START button. **MAN** will always flash as a reminder that the PUMP CONTROL is in MANUAL. Spray width is only selectable in gang bar control. Ground speed is never selectable and the pump speed is not selectable in manual pump control, bar circulate, or when spraying.

Second Operating Screen

```
0 SQYD      0 GAL  
0 FT       100 F
```

The second operating screen displays the square yards, gallons sprayed and distance in feet traveled as well as the asphalt tank temperature. The accumulated values can be used for recording shots or the area and distance can be used for dry measuring. The accumulated values will exceed the displayed values after 999,999. The temperature is displayed as 999 when the RTD is not connected to the computer.

Third Operating Screen

100 %SUF 50 %CIRC
5 MIN GPM

The third operating screen allows for quick set up of the start-up factor, bar circulation rate factor, and minimum pump speed. This screen is not viewable when the PUMP CONTROL is in MANUAL. The start up factor changes the pump speed for the first half-second of spraying. 100 %SUF makes no change. Higher start-up factors increase the pump speed while lower start up factors decrease the pump speed. In BAR CIRCULATE, the asphalt pump rate target is calculated based on the displayed spray width, application rate, and the setting of the %CIRC factor. A setting of 50% is equivalent to a spray pump rate while traveling at 150 FPM. The minimum pump speed is used in bar circulate and spray. In either operation, when all of the One Foot switches are turned OFF, the minimum pump speed is not used and the pump speed goes to zero.

Information Messages

Hot Hydraulics

WARNING
HYDRAULICS HOT

The hot hydraulics warning flashes on the display when the hydraulic reservoir temperature reaches or exceeds 200 °F.



WARNING

Stop immediately and determine the cause of the high temperature. Failure to do so will result in damage to hydraulic components.

VWSB Position

VWSB POSITION FAULT

The variable width spray bar (VWSB) position fault warning flashes on the display when the VW bar control is selected and the spray bar is calibrated incorrectly or wiring to or in the smart cylinder is disconnected or damaged.

Low Level

LOW LEVEL

The low level warning flashes on the display when in bar circulate or spray and the asphalt tank material level gets low.

Radar Calibration

RADAR CALIBRATE FAULT

The radar calibration fault flashes on the display after calibrating the ground speed when the radar is either not connected to the computer or produces a signal that is out of the acceptable range.

Left Module

LEFT MODULE
NOT RESPONDING

The left module not responding warning flashes on the display when VW bar control is selected and the left valve driver is not present on the CAN bus. There are several reasons why the module might not be recognized on the CAN bus. It may be unplugged from the CAN bus or electrical power or may be damaged.

Right Module

RIGHT MODULE
NOT RESPONDING

The right module not responding warning flashes on the display when VW bar control is selected and the right valve driver is not present on the CAN bus. There are several reasons why the module might not be recognized on the CAN bus. It may be unplugged from the CAN bus or electrical power or may be damaged.

Hydraulic Pump

HYD PUMP FAULT

The hydraulic pump fault warning flashes on the display if the EDC is not connected to the computer when the START button is selected in auto pump control.

Application Pump

OVER APPLICATION PUMP AT MIN

UNDER APPLICATION PUMP AT MAX

These messages will/may only appear in the spraying operation. The over application message indicates that the ground speed is too slow

and/or possibly the engine speed is too fast, while the under application message indicates that the ground speed is too fast and/or possibly the engine speed is too slow.

Loading

Loading Through the Manhole

To reduce the risk of accidental discharge of asphalt, the asphalt pump should not be running, the 4 way valve should be in tank circulate, all tank valves should be closed, and both the load and transfer line caps should be on and secured when loading through the manhole.

WARNING

To prevent possible injury, always open the manhole cover slowly. Pressure build up in the tank may cause the cover to burst open.

Refer to Figure 11 for the following procedures.

1. Park the Distributor in the desired location for loading overhead through the manhole.
2. Set the truck parking brake and turn off engine.
3. Before exiting the cab, turn the POWER switch OFF.
4. When the desired amount of product is in the tank and the supply tank valve is closed, close the manhole lid and properly secure before moving the Distributor.

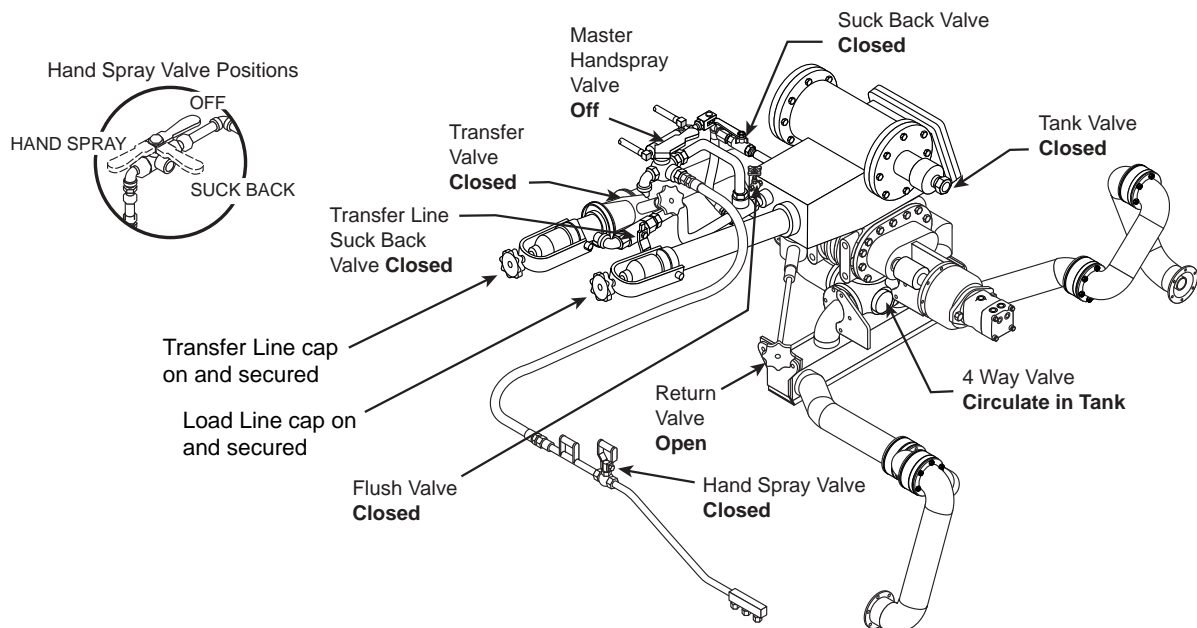

Figure 11. Valve Positions for Loading Through the Manhole.

! WARNING

To prevent possible burns from foaming or violent eruption: Do not load tank with material temperature over 200 °F if water or condensation is present in tank, or if emulsion was used in the previous load. Do not heat material over 200 °F if moisture or emulsion is present in tank.

Connections and Preliminary Checks

! WARNING

To prevent possible burns from leaking material, be sure all pipe, cap and hose connections are secure before opening valves or beginning any operation.

! WARNING

To prevent possible burns to operators or bystanders, or possible equipment damage, do not start any operation if any control settings are unknown.

! WARNING

To prevent an explosion or fire hazard, keep burning cigarettes or other sources of combustion away from manholes and overflow vents.

! WARNING

To prevent burns, always wear eye protection, long sleeve shirt, insulated gloves, boots, and long pants outside the boots when working around the Distributor.

Check Strainers

Before removing the load line cap or strainer access cover perform the suck back operation to ensure that there is not material in the strainer box. Finally ensure that the tank valve(s) are closed and the POWER switches are OFF before removing the load line cap and strainer access cover.

Ensure that both the fill line and the suction strainers are clean and properly installed.

Ensure that all connections on the Distributor are tight to prevent asphalt leaks. **Do not** pressurize the fill line with an external pump.

! WARNING

Before removing the fill line cap, make certain that the asphalt pump is turning and the suction valve is closed.

Using the Measuring Stick

The measuring stick is only accurate when the tank is level.

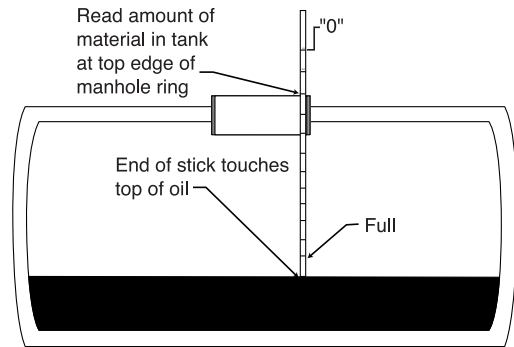

Figure 12. Using the Measuring Stick.

Loading Through the Load Line

! WARNING

To prevent possible burns from foaming or violent eruption: Do not load tank with material temperature over 200 °F if water or condensation is present in tank, or if emulsion was used in the previous load. Do not heat material over 200 °F if moisture or emulsion is present in tank.

Refer to Figure 13 for the following procedures.

1. Park the Distributor in the desired location for loading through the fill line.
2. Set the truck parking brake.
3. The engine must be running and the optional transmission PTO must be engaged.
4. At the rear control panel, the PUMP CONTROL switch must be in AUTO and the PUMP SPEED must be at zero (full counter clockwise) before continuing.
5. On the cab control panel, turn the POWER switch ON.

At the rear of the distributor:

Set or confirm the following:

- Tank valve **closed**
- Return valve **open**
- Bar suck back valve(s) **closed**
- Master hand spray valve **closed**
- Transfer line suck back valve **closed**
- Transfer line valve **closed**
- Flush valve **closed**
- Load and transfer line caps are in place and secured.

At the rear of control panel:

1. Turn the Function knob to the LOAD/ TRANSFER position.
2. Turn the POWER switch ON. Both the front and rear power switches must be ON to operate.
3. Turn the PUMP CONTROL switch to MANUAL.
4. Turn the PUMP SPEED knob so the asphalt pump turns slowly.
5. Remove the load line cap.
6. Connect the load line to the supply tank through an asphalt hose.
7. Open the tank valve on the supply tank.
8. Decrease the PUMP SPEED to zero.
9. Turn the PUMP CONTROL switch to AUTO.
10. Press START. The pump will start turning at the desired loading rate.

11. When the desired amount of product is in the Distributor tank, close the supply tank valve.
12. At the supply tank, carefully open the bleeder valve or break the hose connection until a strong vacuum is heard. It may be necessary to reduce the pump speed in order to overcome pump vacuum when breaking the hose connection. Elevating the hose above the load line connection will allow maximum drainage of the hose.
13. Disconnect the hose from the load line.
14. Replace the load line cap and secure.
15. If no other operation will be performed, it may be necessary to flush the pump before stopping the pump in the next step. Otherwise go to the instructions for the desired operation.
16. To stop the pump in MANUAL control select AUTO control. To stop the pump in AUTO control either turn the POWER switch OFF or with the PUMP SPEED knob fully counter clockwise select MANUAL control. In AUTO control selecting another position on the the FUNCTION knob will also stop the pump.

NOTE: The pump can be stopped and the automatic tank valve can be closed immediately at any time during operation by turning the POWER switch OFF. Before turning the POWER switch back ON, turn the PUMP SPEED knob to zero if the PUMP CONTROL switch is in MANUAL, to prevent the pump from turning.

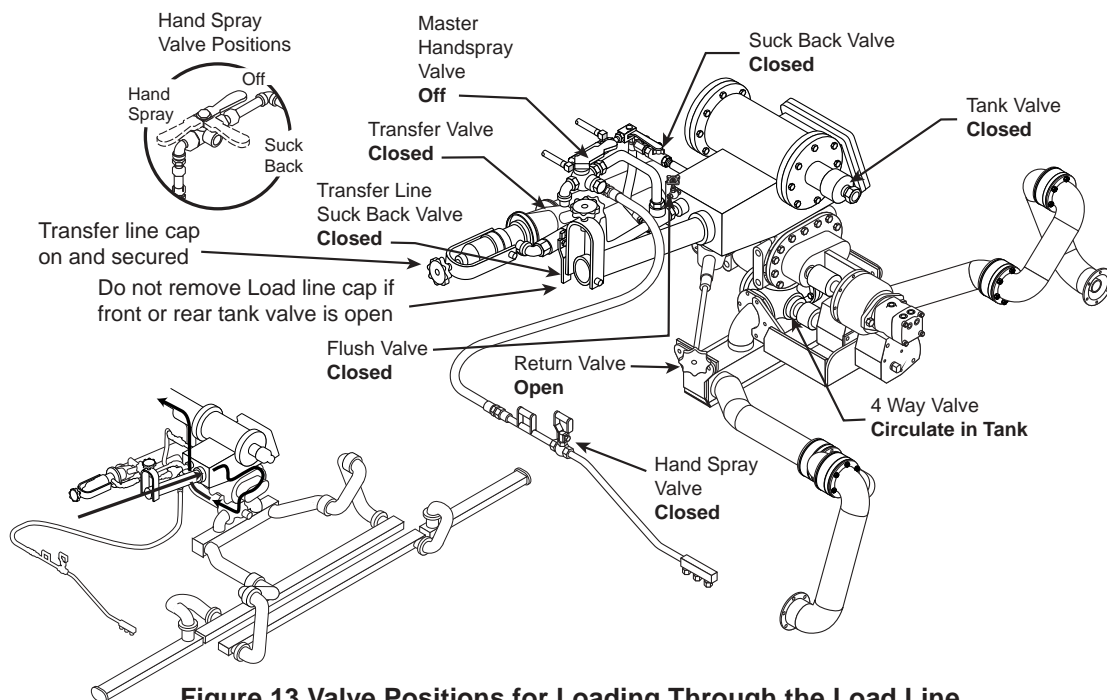





Figure 13 Valve Positions for Loading Through the Load Line.

A pump rate of 100 GPM is recommended to begin the loading operation. The pump rate can be increased at any time after loading has begun. Depending on material viscosity, as the loading rate is increased, the asphalt pump may cavitate. When this happens, the pump will make a distinctive sound, easily recognized with experience. Short periods of operation while the pump is cavitating will not damage the pump but you should not operate the pump in this condition for extended periods.

Higher pump speeds will not load thicker materials faster. Lighter materials, or heavy materials which are already at spraying temperature, may be loaded at faster rates.

 WARNING
To prevent possible burns from material overflow, allow sufficient space in the tank for expansion of the material when heating.

 WARNING
To prevent an explosion or fire hazard, keep burning cigarettes or other sources of combustion away from manholes and overflow vents.

 WARNING
To prevent burns, always wear insulated gloves when handling spray bar sections or hoses.

Circulating in the Tank

If the product is too cold to be circulated, some heating with the burners will be needed to increase the temperature enough to be able to start circulating. Refer to the portion of this operating manual for instructions on your particular type of burner.

Refer to Figure 14 for the following procedures.

1. If heating, park the Distributor broadside to the wind.
2. Set the truck parking brake.
3. The engine must be running and the optional transmission PTO must be engaged.
4. At the rear control panel, the PUMP CONTROL switch must be in AUTO and the PUMP SPEED must be at zero (full counter clockwise) before continuing.
5. On the cab control panel, turn the POWER switch ON.

At the rear of the distributor:

Set or confirm the following:

- Return valve **open**
- Bar suck back valve(s) **closed**
- Master hand spray valve **closed**
- Transfer line suck back valve **closed**
- Transfer line valve **closed**
- Flush valve **closed**
- Load and transfer line caps are in place and secured.

At the rear of control panel:

1. Turn the Function knob to TANK CIRCULATE. (Optional manual tank valve should be opened.)
2. Turn the POWER switch ON.
3. Put the PUMP CONTROL to AUTO.
4. Press START. The pump will start turning at the desired circulation rate.
5. If no other operation will be performed, go to the next step. Otherwise go to the instructions for the desired operation.
6. The optional manual tank valve should be closed at this time before stopping the pump.
7. To stop the pump in MANUAL control select AUTO control. To stop the pump in AUTO control either turn the POWER switch OFF or with the PUMP SPEED knob fully counter clockwise select MANUAL control. In AUTO control selecting another position on the the FUNCTION knob will also stop the pump.

8. Flush the pump if necessary before quitting.

NOTE: The pump can be stopped and the automatic tank valve can be closed immediately at any time during operation by turning the POWER switch OFF. Before turning the POWER switch back ON, turn the PUMP SPEED to zero if the PUMP CONTROL switch is in MANUAL, to prevent the pump from turning.

! WARNING

To prevent possible burns, use extreme caution when using a torch to heat the pump. Asphalt accumulated around the pump may ignite when heating the pump with a torch.

! WARNING

To prevent an explosion or fire hazard, when the burners go out, shut off the fuel supply to both burners and allow the flues to ventilate for at least 3 minutes before re-lighting the burners.

! WARNING

To prevent an explosion, do not operate the burners when the vehicle is unattended, when the vehicle is in motion, or with the vehicle in a confined area.

! WARNING

To prevent possible burns from material overflow, allow sufficient space in the tank for expansion of the material when heating.

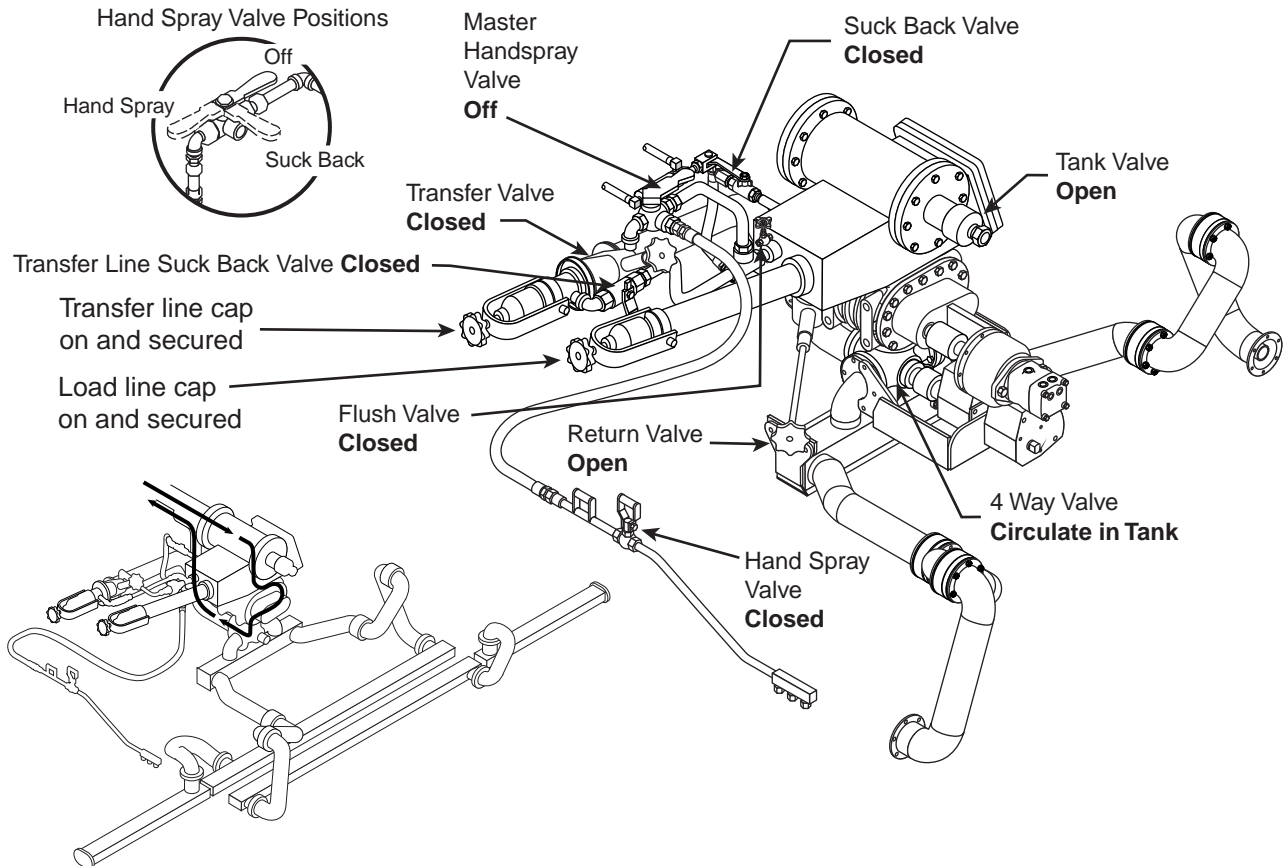

Figure 14. Valve Positions for Circulating in the Tank.

Circulating Product in the Bar

Refer to Figure 15 for the following procedures.

1. If heating, park the Distributor broadside to the wind.
2. Set the truck parking brake.
3. The engine must be running and the optional transmission PTO must be engaged.
4. At the rear control panel, the PUMP CONTROL switch must be in AUTO and the PUMP SPEED must be at zero (full counter clockwise) before continuing.
5. Turn the SPRAY switch OFF.
6. Set the application rate with a MEMORY switch or by using the SELECT and VALUE switches.
7. Set the desired spray width with the One Foot switches. The spray bar should always be warmed before moving it in order to obtain the desired spray width. Lowering the wings allow for increased spray width selections.

8. Turn the POWER switch ON in the cab panel.

At the rear of the distributor:

Set or confirm the following:

- Return valve **open**
- Bar suck back valve(s) **closed**
- Master hand spray valve **closed**
- Transfer line suck back valve **closed**
- Transfer line valve **closed**
- Flush valve **closed**
- Load and transfer line caps are in place and secured.

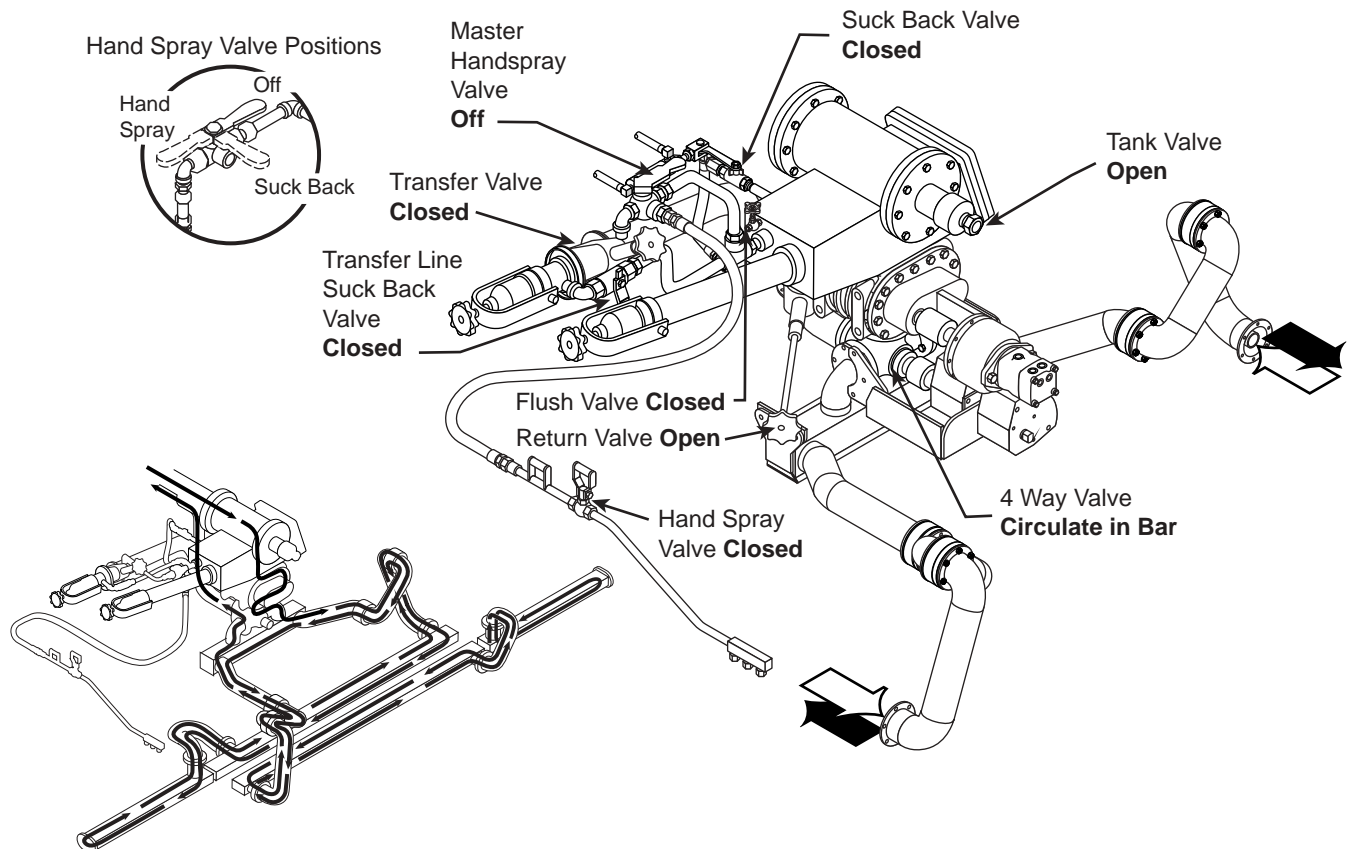

Figure 15. Valve Positions for Circulating in the Bar.

At the rear control panel:

1. Turn the Function knob to BAR CIRCULATE.
(Optional manual tank valve should be opened.)
2. Turn the cab POWER switch ON.
3. Put the PUMP CONTROL to AUTO.
4. Press START. The pump will start turning at the desired circulation rate.
5. If no other operation will be performed, go to the next step. Otherwise go to the instructions for the desired operation.

NOTE: The pump can be stopped and the automatic tank valve can be closed immediately at any time during operation by turning the POWER switch OFF. Before turning the POWER switch back ON, turn the PUMP SPEED to zero if the PUMP CONTROL switch is in MANUAL, to prevent the pump from turning.

Circulate product long enough to ensure removal of all air from the bar and to heat the spray bar valves sufficiently. For better material circulation, in the bar ends, the wings should be lowered. Before moving the bar, circulate some hot material through the bar. This allows the bar to warm up and also extends the life of the bar seals and o-rings.



WARNING

To prevent an explosion or fire hazard, ensure that the burners are extinguished before removing any material from the tank in any manner. Liquid petroleum (LP) burners can support a flame for several minutes after the fuel supply is turned off.



CAUTION

To prevent excessive pressure in the spray bar, the asphalt pump speed should not exceed 160 GPM while circulating in the spray bar.

Spraying (Auto)

Refer to Figure 16 for valve positions.

1. Complete the procedure for circulating in the spray bar. See the *Circulating Product in the Bar* section of this manual.
2. Unlatch the spray bar.
3. Lower the spray bar to the desired spray height.
4. Set the desired spray width using the One Foot switches and configuring the spray bar to the desired width with the wings. Extend or retract the right and left spray bars as needed.
5. Select the transmission gear and rear axle speed that produces the desired engine and ground speed for spraying.
6. Release the parking brake and start the Distributor moving.
7. When the spray bar reaches the beginning of the shot, turn the SPRAY switch ON.

8. When the spray bar reaches the end of the shot turn the SPRAY switch OFF.
9. Continue spraying by turning ON and OFF the SPRAY switch as desired. When finished, follow the instructions for bar suck back. See the *Spray Bar Suck Back* section.



WARNING

Do not run the pump above rated capacity of 400 GPM. Damage to equipment may occur.

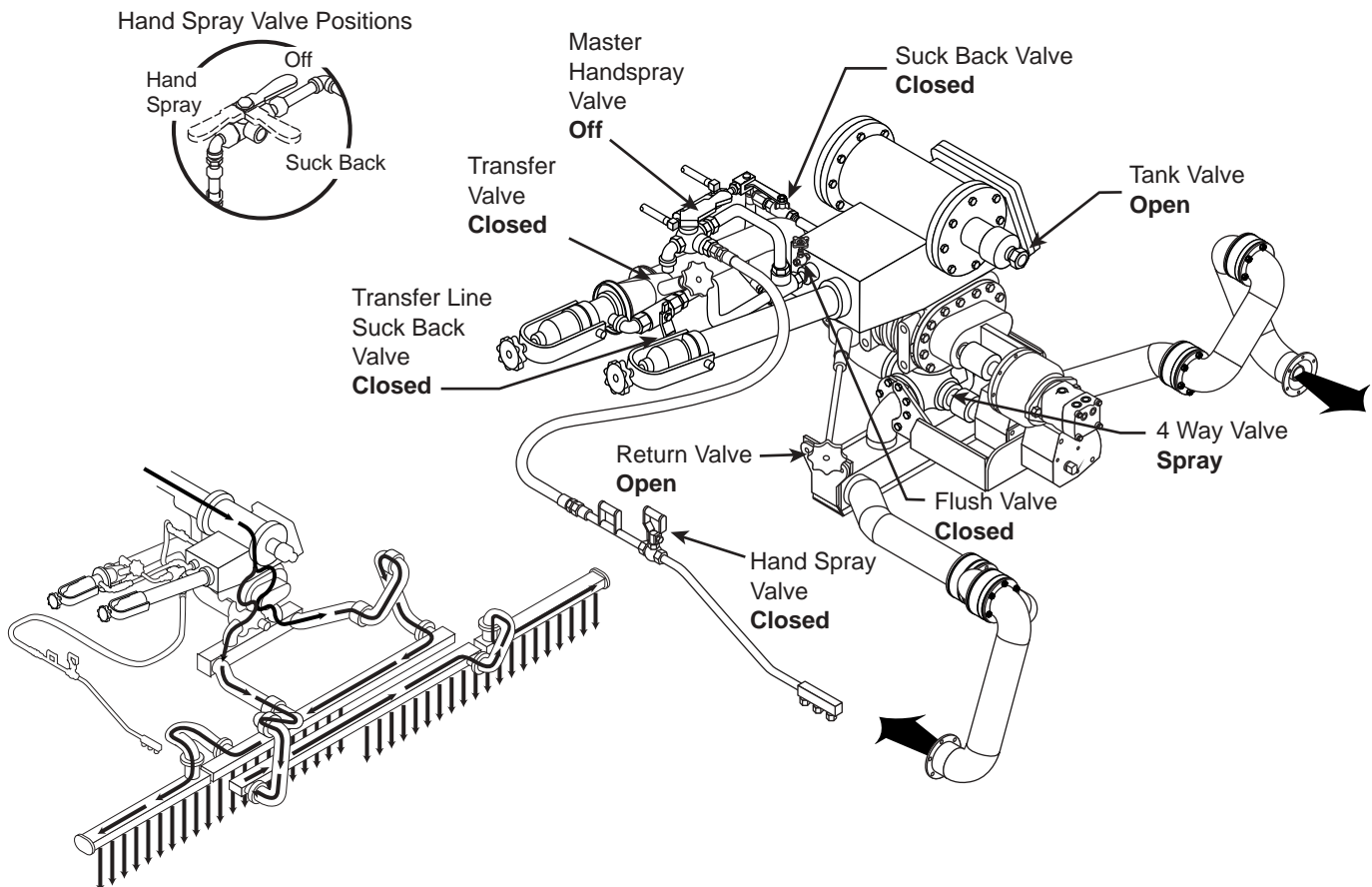

Figure 16. Valve Positions for Spraying Through the Bar.

Hand Spraying

Refer to Figure 17 for the following procedure.

WARNING

To prevent burns from hot asphalt when handspraying, hold the handspray gun in proper position and watch for other people.

WARNING

To prevent burns, always wear eye protection, long sleeve shirt, insulated gloves, boots, and long pants outside the boots when working around the Distributor.

1. Set the truck parking brake.
2. The engine must be running and the optional transmission PTO must be engaged.
3. At the rear control panel, the PUMP CONTROL switch must be in AUTO and the PUMP SPEED must be at zero (full counter clock-wise) before continuing.
4. On the cab control panel, turn the POWER switch ON.

At the rear of the distributor:

Set or confirm the following:

- Return valve **open**
- Bar suck back valve(s) **closed**
- Master hand spray valve **closed**
- Transfer line suck back valve **closed**
- Transfer line valve **closed**
- Flush valve **closed**
- Load and transfer line caps are in place and secured.

At the rear control panel:

1. Turn the Function knob to HAND SPRAY.
(Optional manual tank valve should be open)
2. Turn the POWER switch ON.
3. Put the PUMP CONTROL to AUTO.
4. Press START. The pump will start turning at the desired rate.
5. Move the master hand spray valve into the hand spray position.
6. Open the hand spray valve on the hand spray wand.

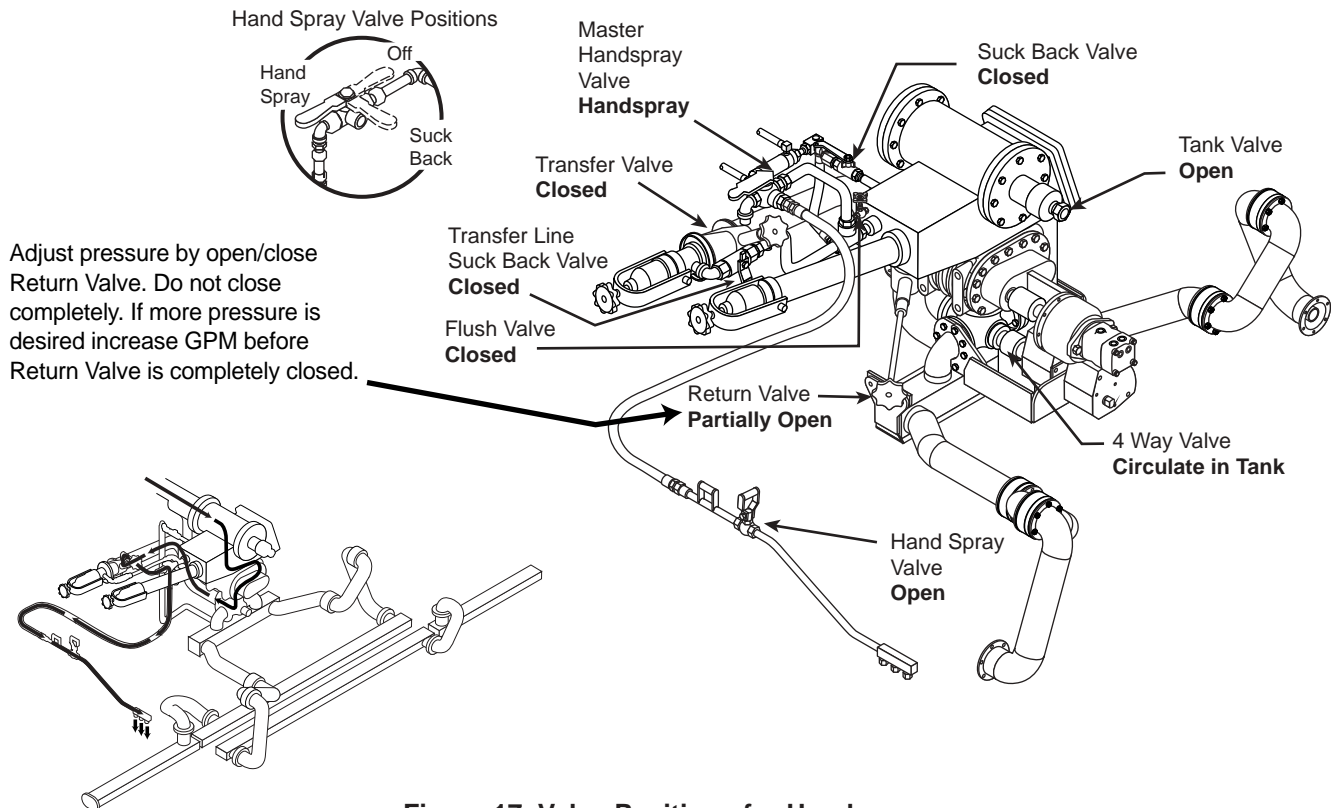

Figure 17. Valve Positions for Handspray.

7. Gradually turn the return valve handle clockwise to increase hand spray pressure. The useful range for hand spraying is typically between an inch and a half inch of exposed valve stem (area between stem extension coupling and valve body). When the desired application cannot be obtained with the minimum exposed valve stem, repeat the adjustment after first opening the return valve and then increasing the pump speed.
8. Continue hand spraying by opening and closing the hand spray valve on the wand as needed.
9. When finished, follow the instructions in the *Hand Spray Suck Back* section of this manual.

NOTE: The pump can be stopped and the automatic tank valve can be closed immediately at any time during operation by turning the POWER switch OFF. Before turning the POWER switch back ON, turn the PUMP SPEED to zero if the PUMP CONTROL switch is in MANUAL, to prevent the pump from turning.



CAUTION

When using rear pump control, engine RPM changes will affect asphalt pump speed.

Bar Suck Back Override

This optional feature is designed for quick in-cab switching between bar circulate and bar suck back for units equipped with automatic tank and bar suck back valves. When the BAR SUCK BACK OVERRIDE switch is ON, all automatically controlled valves are set to their correct positions for BAR SUCK BACK. This overrides any settings of the Function knob and stops the asphalt pump when the PUMP CONTROL switch is in AUTO.

The following steps performed in the cab while the Function knob is turned to BAR CIRCULATE.

1. Turn the BAR SUCK BACK OVERRIDE switch ON.
2. Press START. The pump will start turning at the desired rate. 200 GPM is recommended.
3. If complete bar suck back is desired, follow the instructions for bar suck back, beginning with the opening of the left bleeder valve. Otherwise continue to the next step.
4. Turn the BAR SUCK BACK OVERRIDE switch OFF.
5. Press START. The pump will start turning at the desired circulation rate.

Note: The pump can be stopped and the automatic tank valve can be closed immediately at any time during operation by turning the POWER switch OFF. Before turning the POWER switch back ON, turn the PUMP SPEED to zero if the PUMP CONTROL switch is in MANUAL, to prevent the pump from turning.

Spray Bar Suckback

Refer to Figure 18 for the following procedures.

1. Park the Distributor and set the truck parking brake.
2. The engine must be running and the optional transmission PTO must be engaged.
3. At the rear control panel, the PUMP CONTROL switch must be in AUTO and the PUMP SPEED must be at zero (full counter clockwise) before continuing.
4. On the cab control panel, turn the POWER switch ON.

At the rear of the distributor:

Set or confirm the following:

- Tank valve **closed**
- Return valve **open**
- Master hand spray valve **closed**
- Transfer line suck back valve **closed**
- Transfer line valve **closed**
- Flush valve **closed**
- Load and transfer line caps are in place and secured.

At the rear control panel:

1. Turn the Function knob to BAR SUCK BACK. (Optional manual tank valve should be closed and the optional manual bar suck back valve(s) should be open.)
2. Turn the POWER switch ON.
3. Put the PUMP CONTROL to AUTO.
4. Press START. The pump will start turning at the desired rate. 200 GPM is recommended.
5. Open the bleeder valve on the left wing until a strong vacuum is heard and then close valve.
6. Open the bleeder valve on the right wing until strong vacuum is heard and then close valve.
7. If no other operation will be performed, go to the next step. Otherwise go to the instructions for the desired operation.
8. Close the optional manual bar suck back valve.
9. To stop the pump in MANUAL control select AUTO control. To stop the pump in AUTO control either turn the POWER switch OFF or with the PUMP SPEED knob fully counter clockwise select MANUAL control. In AUTO

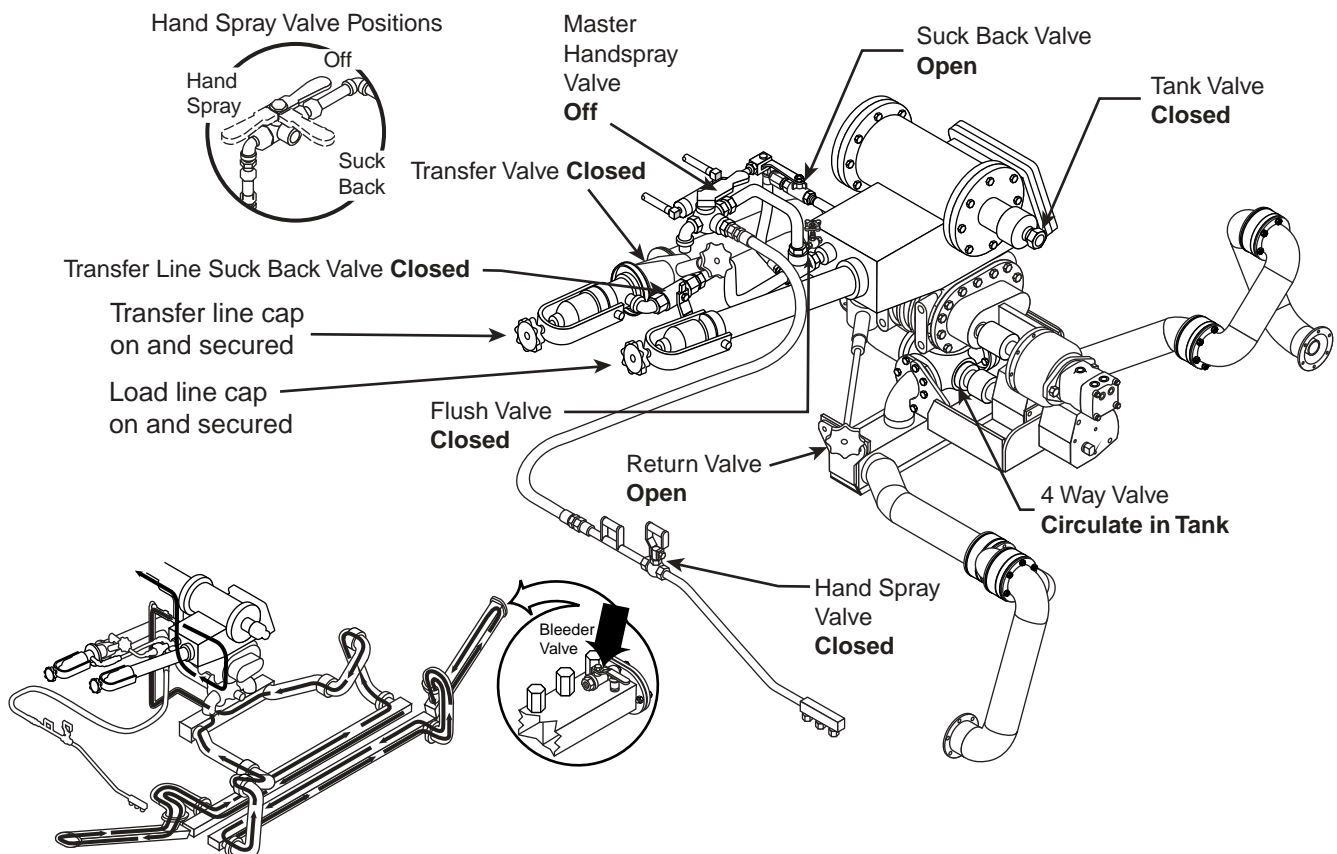

Figure 18. Valve Positions for Spray Bar Suck Back.

control selecting another position on the the FUNCTION knob will also stop the pump. Changing the position of the Function knob will also stop the pump but could also reopen the tank valve.

10. Flush the pump if necessary before quitting.

NOTE: The pump can be stopped and the automatic tank valve can be closed immediately at any time during operation by turning the POWER switch OFF. Before turning the POWER switch back ON, turn the PUMP SPEED to zero if the PUMP CONTROL switch is in MANUAL, to prevent the pump from turning.



WARNING

To prevent possible burns from hot asphalt spray, do not stand, or allow anyone to stand, where accidental opening of a valve may cause contact with hot asphalt.

For asphalts like AC it is recommended that this procedure be repeated a second time, after which adding solvent such as diesel fuel through each bleeder will quickly flush the spray bar.

If not equipped with the electric pump, it is helpful to pour some diesel fuel down the fill line after all operations are completed. The diesel fuel will remain in the pump overnight to keep the pump free for the next morning's operation.

Ensure that the self flush valve is closed at the end of this function, or before loading or circulating asphalt to eliminate chances of inducing asphalt into the self flush fuel tank.

Flushing Operations

Normally the suckback procedure will remove sufficient material from the circulating system to negate the need for draining the circulating system and spray bar before proceeding with the wash out operation. The flushing operation requires only three quarts of flushing solvent. This small amount is not sufficient to fill the lines to the tank, thus preventing solvent from being forced into the tank.

A common practice following completion of the flushing procedure and subsequent shutdown is to pour one to two quarts of solvent into the fill line. This softens or dissolves the residual asphalt in the pump. Allow these solvents to remain in the system until the next use.

Bar Flush (Auto)

Refer to Figure 19 for the following procedures.

1. Park the Distributor and set the truck parking brake.
2. The engine must be running and the optional transmission PTO must be engaged.
3. At the rear control panel, the PUMP CONTROL switch must be in AUTO and the PUMP SPEED must be at zero (full counter clockwise) before continuing.
4. On the cab control panel, turn the POWER switch ON.

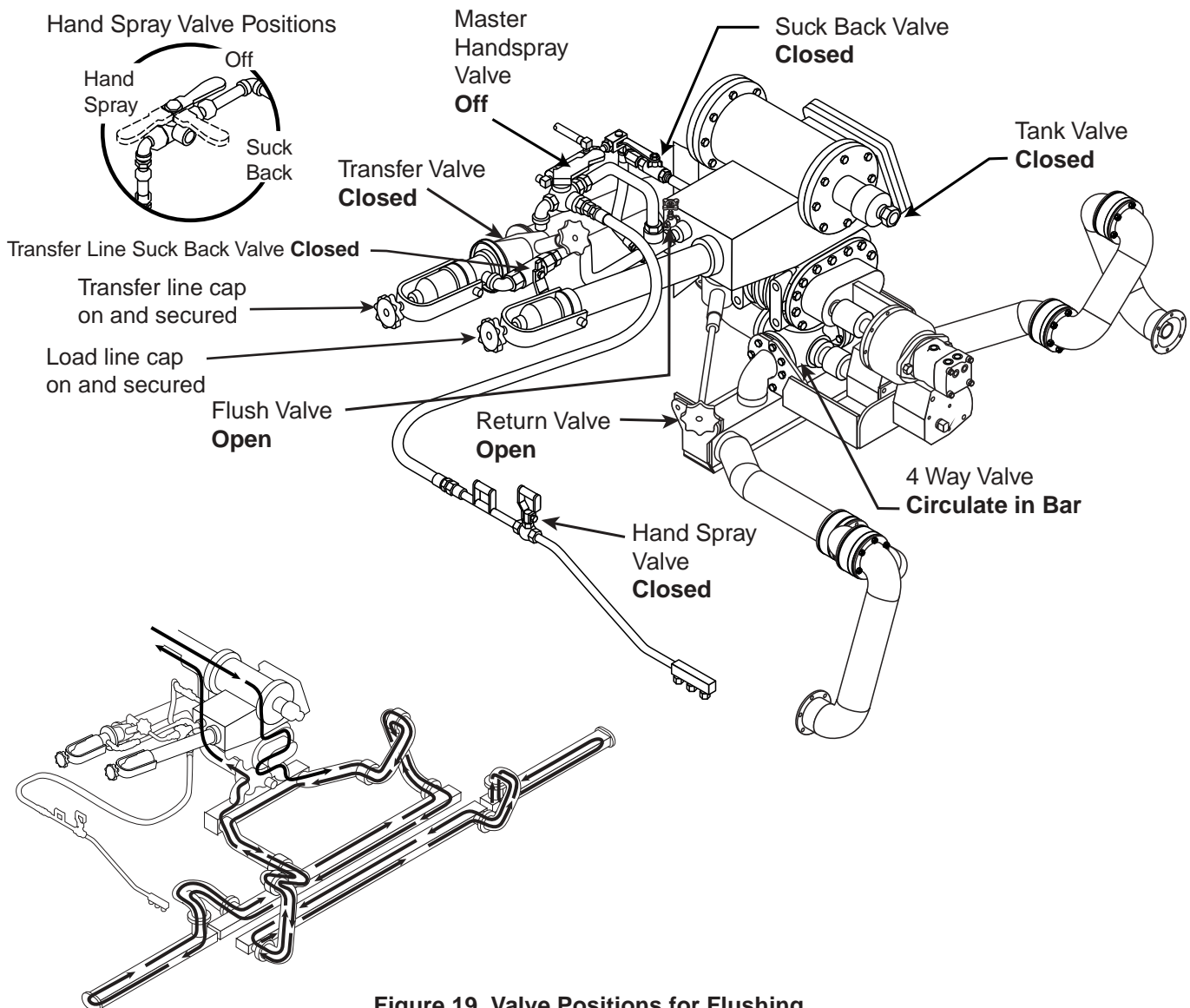

Figure 19. Valve Positions for Flushing.

At the rear of the distributor:

Set or confirm the following:

- Tank valve **closed**
- Bar suck back valve(s) **closed**
- Return valve **open**
- Master hand spray valve **closed**
- Transfer line suck back valve **closed**
- Transfer line valve **closed**
- Load and transfer line caps are in place and secured.

At the rear control panel:

1. Turn the Function knob to BAR FLUSH.
2. Turn the POWER switch ON.
3. Put the PUMP CONTROL to AUTO.
4. Press START. The pump will start turning at the desired circulation rate.
5. Open the flush valve for 2 minutes.
6. Close the flush valve.
7. If no other operation will be performed, go to the next step. Otherwise go to the instructions for the desired operation.
8. To stop the pump in MANUAL control select AUTO control. To stop the pump in AUTO control either turn the POWER switch OFF or with the PUMP SPEED knob fully counter clockwise select MANUAL control. In AUTO control selecting another position on the the FUNCTION knob will also stop the pump. Changing the position of the Function knob will also stop the pump but could also reopen the tank valve.

NOTE: The pump can be stopped and the automatic tank valve can be closed immediately at any time during operation by turning the POWER switch OFF. Before turning the POWER switch back ON, turn the PUMP SPEED to zero if the PUMP CONTROL switch is in MANUAL, to prevent the pump from turning.

Bar Flush (Manual)

Refer to Figure 14 for the following procedures.

1. Park the Distributor and set the truck parking brake.
2. The engine must be running and the optional transmission PTO must be engaged.
3. At the rear control panel, the PUMP CONTROL switch must be in AUTO and the PUMP SPEED must be at zero (full counter clockwise) before continuing.

4. On the cab control panel, turn the POWER switch ON.

At the rear of the distributor:

Set or confirm the following:

- Tank valve **closed**
- Return valve **open**
- Master hand spray valve **closed**
- Transfer line suck back valve **closed**
- Transfer line valve **closed**
- Flush valve **closed**
- Load and transfer line caps are in place and secured.

At the rear control panel:

1. Turn the Function knob to BAR SUCK BACK.
2. Turn the POWER switch ON.
3. Put the PUMP CONTROL to AUTO.
4. Press START. The pump will start turning at the desired rate. 200 GPM is recommended.
5. Open the bleeder valve on the left wing. After a strong vacuum is heard, add 1 quart of solvent through the valve and then close the valve.
6. Open the bleeder valve on the right wing. After a strong vacuum is heard, add 1 quart of solvent through the valve and then close the valve.
7. If no other operation will be performed, go to the next step. Otherwise go to the instructions for the desired operation.
8. To stop the pump in MANUAL control select AUTO control. To stop the pump in AUTO control either turn the POWER switch OFF or with the PUMP SPEED knob fully counter clockwise select MANUAL control. In AUTO control selecting another position on the the FUNCTION knob will also stop the pump. Changing the position of the Function knob will also stop the pump but could also reopen the tank valve.
9. Flush the pump if necessary before quitting.

NOTE: The pump can be stopped and the automatic tank valve closed immediately at any time during operation by turning the POWER switch OFF. Before turning the POWER switch back ON, turn the PUMP SPEED to zero if the PUMP CONTROL switch is in MANUAL, to prevent the pump from turning.

Unload Operations with External Pump

Refer to Figure 20 for the following procedures.

1. Park the Distributor in the desired location for unloading through the load line.
2. Set the truck parking brake.
3. The engine must be running and the optional transmission PTO must be engaged.
4. At the rear control panel, the PUMP CONTROL switch must be in AUTO and the PUMP SPEED must be at zero (full counter clock-wise) before continuing.
5. On the cab control panel, turn the POWER switch ON.



WARNING

To prevent burns, always wear insulated gloves when handling spray bar sections or hoses.

At the rear of the distributor:

Set or confirm the following:

- Tank valve **closed**
- Return valve **open**
- Bar suck back valve(s) **closed**
- Master hand spray valve **closed**
- Transfer line suck back valve **closed**
- Transfer line valve **closed**
- Flush valve **closed**
- Load and transfer line caps are in place and secured.

At the rear control panel:

1. Turn the Function knob to LOAD/TRANSFER. (Optional manual tank valve should be closed.)
2. Turn the POWER switch ON.
3. Put the PUMP CONTROL to MANUAL.
4. Increase the PUMP SPEED knob so that the asphalt pump turns slowly.

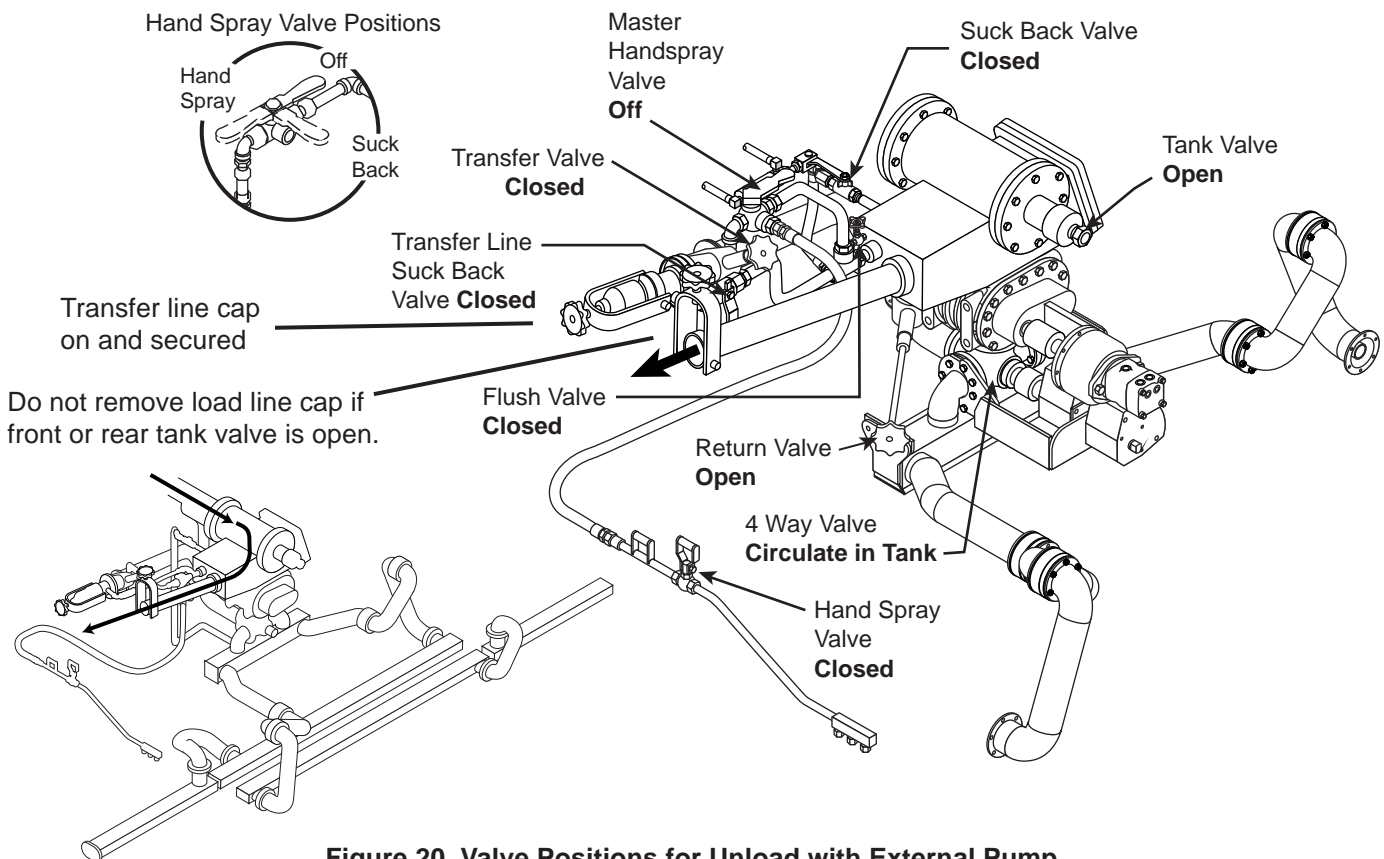

Figure 20. Valve Positions for Unload with External Pump.

5. Remove the load line cap.
6. Connect the load line to the storage tank through an asphalt hose.
7. Decrease the PUMP SPEED to zero.
8. Put the PUMP CONTROL to AUTO
9. Turn the Function knob to UNLOAD (the optional manual tank valve should be open).
10. Open any valves on the storage tank between the asphalt hose and the tank.
11. Run the asphalt pump on the storage tank at the desired pump speed.
12. When finished unloading, turn the Function knob to LOAD/TRANSFER (the optional manual tank valve should be closed).
13. As the load line on the Distributor is being unloaded, carefully open the bleeder valve or break the hose connection until a strong vacuum is heard. It may be necessary to reduce the pump speed in order to overcome pump vacuum when breaking the hose connection. Elevating the hose above the storage tank connection will allow maximum drainage of the hose.

14. Disconnect the hose from the load line.

15. Replace the load line cap and secure.

16. Flush the pump before quitting.

NOTE: The pump can be stopped and the automatic tank valve can be closed immediately at any time during operation by turning the POWER switch OFF. Before turning the POWER switch back ON, turn the PUMP SPEED to zero if the PUMP CONTROL switch is in MANUAL, to prevent the pump from turning.



WARNING

To prevent burns, always wear insulated gloves when handling spray bar sections or hoses.

Unload Operations

with Distributor Pump

Refer to Figure 21 for the following procedures.

1. Park the Distributor in the desired location for unloading through the load line.
2. Set the truck parking brake.
3. The engine must be running and the optional transmission PTO must be engaged.
4. At the rear control panel, the PUMP CONTROL switch must be in AUTO and the PUMP SPEED must be at zero (full counter clockwise) before continuing.
5. On the cab control panel, turn the POWER switch ON.

WARNING

To prevent burns, always wear insulated gloves when handling spray bar sections or hoses.

At the rear of the distributor:

Set or confirm the following:

- Tank valve **closed**
- Bar suck back valve(s) **closed**
- Master hand spray valve **closed**
- Transfer line suck back valve **closed**
- Transfer line valve **closed**
- Flush valve **closed**
- Load, and unload and transfer line caps are in place and secured.

At the rear control panel:

1. Remove the transfer line cap.
2. Connect the transfer line to the storage tank with an asphalt hose.
3. Open the transfer valve.
4. Close the return valve.
5. Open any valves on the storage tank between the asphalt hose and the tank.

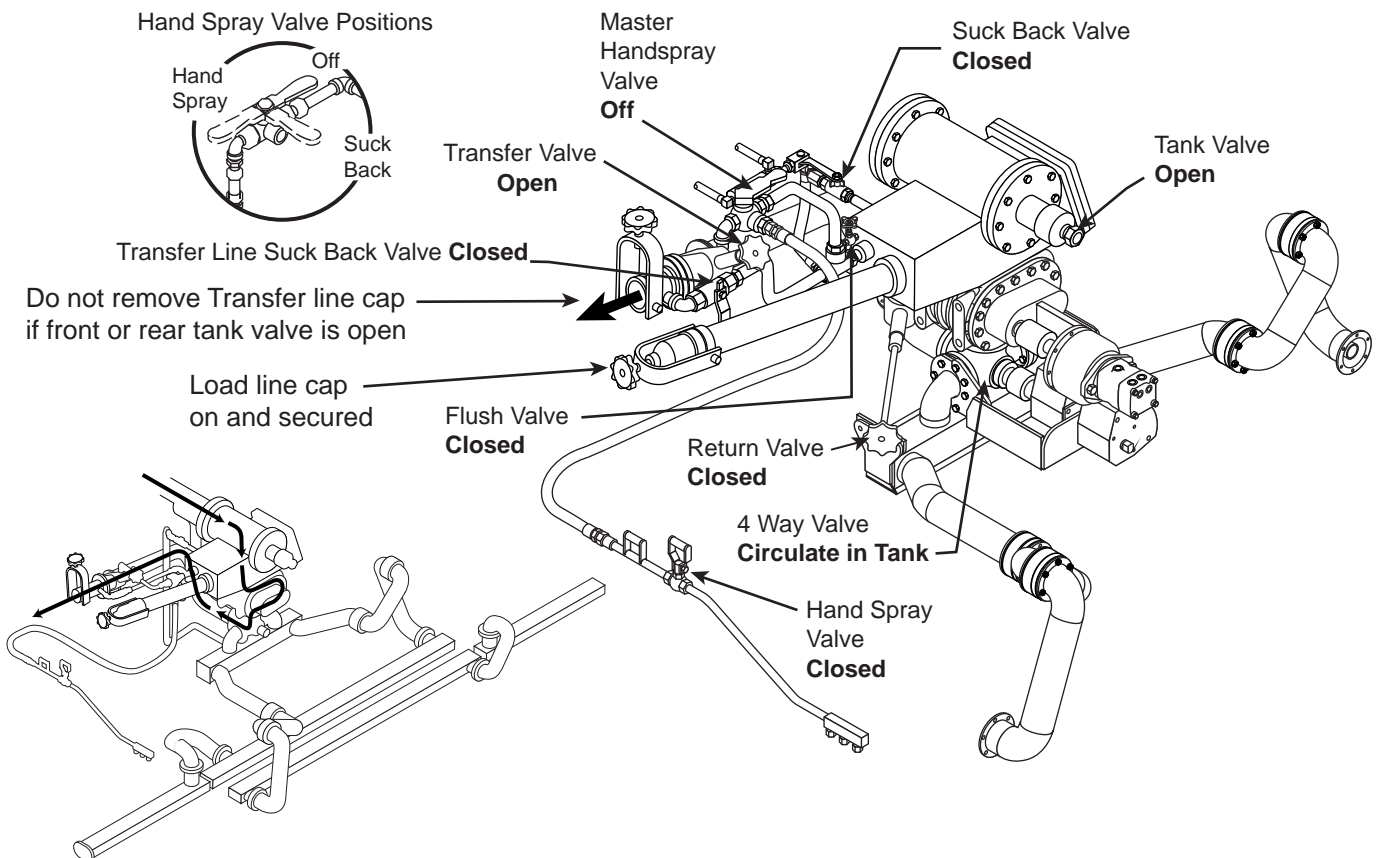

Figure 21. Valve Positions for Unload with Distributor Pump.

6. Turn the Function knob to UNLOAD (the optional manual tank valve should be open).
7. Turn the POWER switch ON.
8. Put the PUMP CONTROL to MANUAL.
9. Increase the PUMP SPEED knob so that the asphalt pump turns slowly.
10. After ensuring the flow between the Distributor and the storage tank is unobstructed, decrease the PUMP SPEED to zero.
11. Put the PUMP CONTROL to AUTO.
12. Press START. The pump will start turning at the desired rate.
13. When finished unloading, turn the Function knob to LOAD/TRANSFER (the optional manual tank valve should be closed).
14. Open the return valve.
15. Close the valve at the storage tank.
16. Close the transfer valve.
17. Open the transfer suck back valve.
18. Press START.
19. At the storage tank, carefully open the bleeder valve or break the hose connection until a strong vacuum is heard. It may be necessary to reduce the pump speed in order to overcome pump vacuum when breaking the hose connection. Elevating the hose above the storage tank connection will allow maximum drainage of the hose.
20. Disconnect the hose from the transfer line.
21. Replace the transfer line cap and secure.
22. Close the transfer suck back valve.
23. Flush the pump before quitting.

NOTE: The pump can be stopped and the automatic tank valve can be closed immediately at any time during operation by turning the POWER switch OFF. Before turning the POWER switch back ON, turn the PUMP SPEED to zero if the PUMP CONTROL switch is in MANUAL, to prevent the pump from turning.

Transfer Operations

Refer to Figure 22 for the following procedures.

1. Park the Distributor for transferring.
2. Set the truck parking brake.
3. The engine must be running and the optional transmission PTO must be engaged.
4. At the rear control panel, the PUMP CONTROL switch must be in AUTO and the PUMP SPEED must be at zero (full counter clockwise) before continuing.
5. On the cab control panel, turn the POWER switch ON.

At the rear of the distributor:

Set or confirm the following:

- Tank valve **closed**
- Bar suck back valve(s) **closed**
- Master hand spray valve **closed**
- Transfer line suck back valve **closed**
- Transfer line valve **closed**
- Flush valve **closed**
- Load and transfer line caps are in place and secured.

At the rear control panel:

1. Turn the Function knob to LOAD/TRANSFER (the optional manual tank valve should be closed).
2. Turn the POWER ON.
3. Remove the transfer line cap.
4. Connect the transfer line to the storage tank through an asphalt hose.
5. Open the transfer valve.
6. Put the PUMP CONTROL switch in MANUAL.
7. Increase the PUMP SPEED so that the asphalt pump turns slowly.
8. Remove the load line cap.
9. Connect the load line to the supply tank with an asphalt hose.
10. Open any valves on the storage tank between the asphalt hose and the tank.
11. Close the return valve.
12. Open the tank valve on the supply tank.
13. Decrease the PUMP SPEED to zero.
14. Put the PUMP CONTROL to AUTO.
15. Press START. The pump will start turning at the desired rate.
16. Close the tank valve on the supply tank when the desired amount of product is in the storage tank.

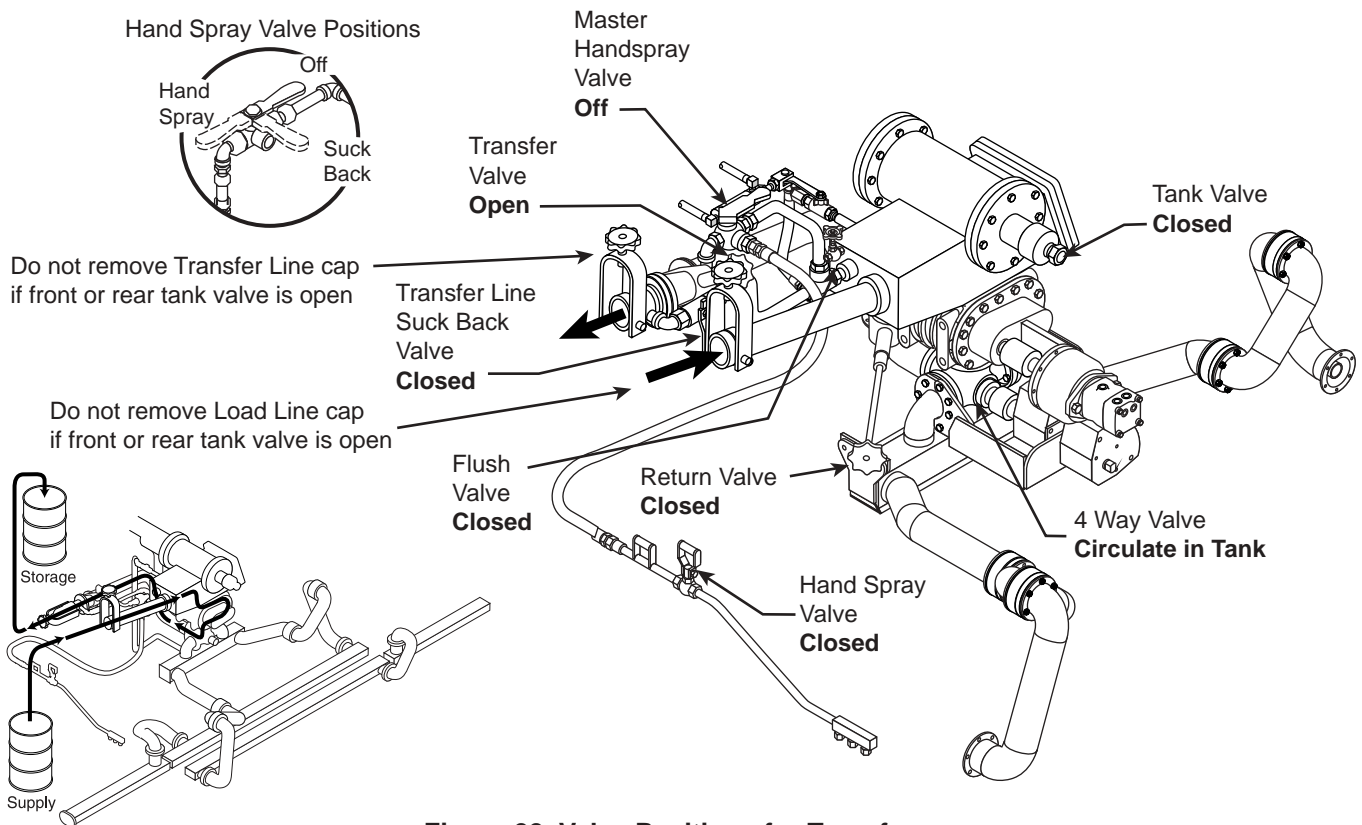

Figure 22. Valve Positions for Transfer.

17. At the supply tank, carefully open the bleeder valve or break the hose connection until a strong vacuum is heard. It may be necessary to reduce the pump speed in order to overcome the pump vacuum when breaking the hose connection. Elevating the hose above the load line connection will allow maximum drainage of the hose.
18. Disconnect the hose from the load line.
19. Replace the load line cap and secure.
20. Put the PUMP CONTROL to MANUAL to stop the pump and then put it back to AUTO.
21. Close the valve at the storage tank.
22. Close the transfer valve.
23. Open the return valve.
24. Open the transfer suck back valve.
25. Press START.
26. At the storage tank, carefully open the bleeder valve or break the hose connection until a strong vacuum is heard. It may be necessary to reduce the pump speed in order to overcome the pump vacuum when breaking the hose connection. Elevating the hose above the load line connection will allow maximum drainage of the hose.
27. Disconnect the hose from the transfer line.
28. Replace transfer line cap and secure.
29. Close the transfer line suck back valve.

30. It may be necessary to flush the pump before doing the next step.
31. To stop the pump in MANUAL control select AUTO control. To stop the pump in AUTO control either turn the POWER switch OFF or with the PUMP SPEED knob fully counter clockwise select MANUAL control. In AUTO control selecting another position on the the FUNCTION knob will also stop the pump.

NOTE: The pump can be stopped and the automatic tank valve can be closed immediately at any time during operation by turning the POWER switch OFF. Before turning the POWER switch back ON, turn the PUMP SPEED to zero if the PUMP CONTROL switch is in MANUAL, to prevent the pump from turning.



WARNING

To prevent burns, always wear insulated gloves when handling spray bar sections or hoses.



WARNING

Suckback of the storage tank line will put material into the tank and could cause an explosion if the tank has not been fully cleaned of emulsion material.

Heating Product in Distributors

Heating Asphalt with Liquid Propane Gas (LPG) Burners

IMPORTANT

Circulating the asphalt in the tank while heating is recommended for faster heating and reduced carbon formation on the flues. Only when the asphalt pump is *Frozen* is it acceptable to operate the burners without circulating asphalt in the tank. However, if the asphalt pump is frozen, carefully apply heat to the pump and start circulating the material as soon as possible.

WARNING

Residual fuel in LPG burners will support a flame for several minutes after the fuel flow has been shut off. After using LPG burners, confirm that all flame has been extinguished before attempting any operation that could release flammable vapors.

Failure to ensure that the flame is completely extinguished could result in an explosion or fire that can cause injury or death.

WARNING

To prevent an explosion or fire hazard:

Position unit broadside to wind whenever possible to prevent volatile fumes from drifting toward burners

Flues **MUST** be covered by a minimum of 6 inches of material when the burners are in operation.

Do not remove material from tank in any manner when the burners are in operation.

Do not drive unit when burners are operating.

Do not operate burners if tank is damaged or leaking.

When burners go out, allow flues to ventilate for several minutes before relighting burners.

Do not heat material beyond the manufacturers recommended temperature.

WARNING

To prevent an explosion or fire hazard: To prevent foaming or violent eruption, do not heat material over 200 °F if moisture is present in tank.

WARNING

To prevent possible burns from material overflow, allow sufficient space in tank for expansion of material when heating.

LPG Supply Tank Requirements

Use only liquid withdrawal type supply tanks for your LPG burners.

Two types of LPG supply tanks are available: tanks for liquid type burners and tanks for vapor type burners. The LPG burners on your Etnyre Distributor require a supply tank for liquid type burners. Liquid type burners will operate from a vapor withdrawal tank, however the amount of heat delivered will be dramatically reduced, and the life of the burner will be shortened.

There are three different types of LPG burners: manual control burners, burners with outfire control, and burners with automatic ignition and temperature limiting control.

Manual Control Burners

Four valves are associated with the operation of the manual control burners: one at the supply tank and three in the burner piping.

The two smaller valves (one at each burner) are bleeder type valves with a small hole in the valve case. Propane liquid is supplied to the bleeder valve directly from the supply tank shutoff valve. Because of the bleeder hole in this valve, it is NOT possible to shut off all of the fuel to the lower burner by shutting the main valve at the burners. The main burner valve will only shut off the upper burner. The lower burner must be shut off using the supply tank valve.

WARNING

Always shut off burners using the main shutoff valve on the supply tank.

The large valve located in the fuel line to the outside or upper burner is a positive cut off valve that allows all fuel to be cut off to the bleeder valve on the upper burner **only**.

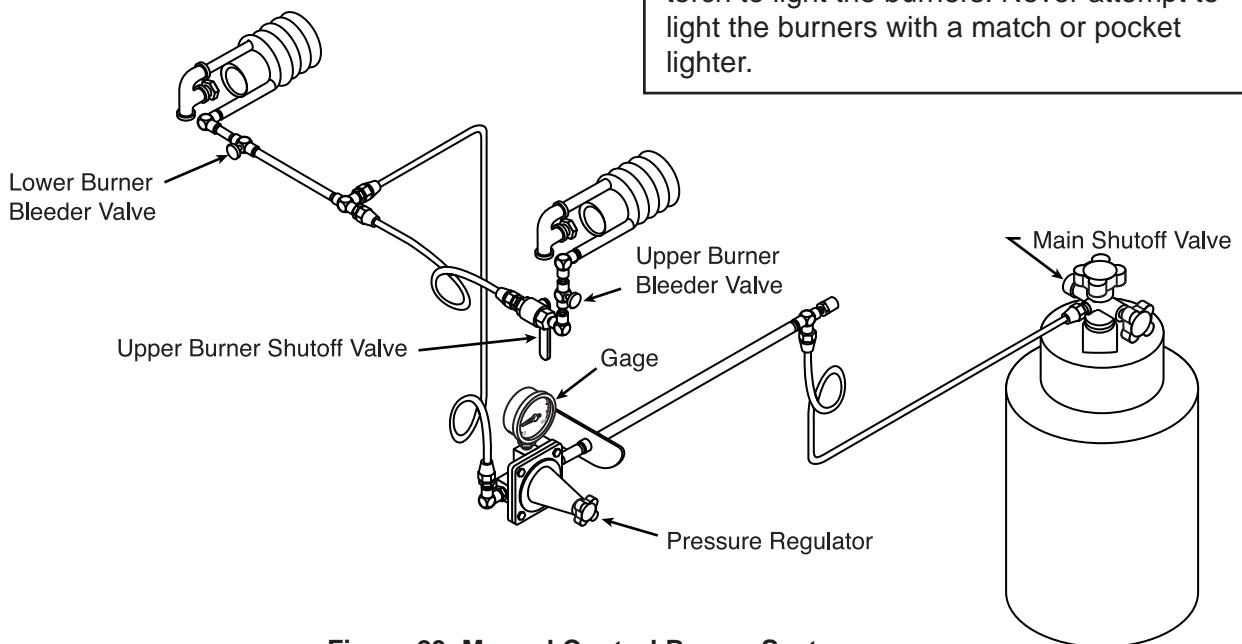

Figure 23. Manual Control Burner System.

Burner Operation

1. Be sure that the main supply valve and the main burner valves are fully closed, and the bleeder valves are turned fully clockwise before starting.
2. Open the dampers in the flue exhaust stacks.
3. Open the valve at the supply tank and immediately light the inside burner. As soon as the burner lights, open the bleeder valve. No preheating is necessary.

IMPORTANT

It is recommended that two persons be involved in lighting the first burner. When the main fuel valve is opened at the tank, there is an immediate trickle of gas passing through the inside burner valve. The longer the gas is allowed to collect in the flue, the more likely there will be a flashback when the burner is ignited. Having one person light the burner while the other opens the main supply valve will reduce the likelihood of a flashback. When the main fuel valve is opened at the bottle or tank, there is an immediate trickle of gas passing through the inside burner bleeder valve. Light the burner immediately.

WARNING

To prevent possible burns, always use a torch to light the burners. Never attempt to light the burners with a match or pocket lighter.

 **WARNING**

A fully charged dry chemical type fire extinguisher must be within easy reach whenever the burners are operating or there is an open flame near the Distributor. Minimum dry chemical capacity of the fire extinguisher should be 10 pounds.

4. Check the fuel pressure at the pressure regulator. Too much pressure for a small asphalt tank will waste fuel. Too little pressure will increase heating time. Some experimentation with the pressure will allow you to determine the most efficient fuel pressure to use. The following is a good rule of thumb.

- 1000-1250 gallon tank- 15 psi
- 1500-1750 gallon tank- 20 psi
- 2000-2250 gallon tank- 25 psi
- 2250-2500 gallon tank- 30 psi
- 2750 gallon and larger- 40 psi

5. If necessary, adjust the flame with the bleeder valve at the burner.

When the LPG burners are operating, the outside of the fuel line up to the first coil of the burner should frost over. If no frost forms it is an indication that the burners are operating on vapor instead of liquid. This condition must be corrected immediately to prevent damage to the burners.

If after the lines frost over, the flame starts to die down and the frost melts off the fuel line, it is likely that there is moisture in the fuel supply tank. Moisture in the fuel can form ice crystals that stop the fuel flow. Your local LPG supplier can add an anti-icing agent to prevent burner icing.

 **IMPORTANT**

There must be at least 6 inches of material covering the entire length of the upper flue before the second burner can be lit.

6. To ignite the second burner ensure that the bleeder valve on the burner is turned fully clockwise. Position a lit torch at the burner nozzle and open up the positive shutoff valve in the line to the burner. As soon as the low fire is established, the bleeder valve can be opened. Never leave operating burners unattended.

 **WARNING**

To prevent possible burns, always use a torch to light the burners. Never attempt to light the burners with a match or pocket lighter.

 **WARNING**

When heating, temperatures within the tank can vary. Shut the burners off when the thermometer reaches a reading 10 °F lower than the desired temperature. Continue to circulate & monitor temperature until temperature stabilizes. Add remaining heat by operating burners for short periods, monitoring stabilized temperature after each period.

 **IMPORTANT**

Calibration of thermometers should be verified to be within + 2% of full scale reading annually.

Certification can be accomplished by a qualified laboratory or by comparing stabilized dial readings to the pencil thermometer reading. Replace any thermometer that does not meet the +2% accuracy requirement.

7. When the desired temperature is reached, **close** the main fuel supply valve, at the LPG tank, **first**. Allow the burners to operate at full capacity until the fuel in the line from the tank burns out, then close both bleeder valves and the positive shutoff valve for the outside burner.

8. Close the exhaust stack dampers to prevent heat loss.

Burners With Outfire Controls

Equipment Design

The burner and the burner control valves are identical to the manual operated burner system.

However, burners with outfire controls are equipped with an outfire control box. The outfire controls consist of two thermocouples, a push start button, an electric fuel solenoid valve, a pressure regulator and a pressure gage.

The heat sensing thermocouples are positioned in each burner. If either burner loses its flame, the thermocouple senses the drop in temperature, and deactivates the fuel solenoid, and the fuel to both burners is shut off.

The only operational differences between the manual burners and burners with the optional outfire controls is the start up and shut down procedures. Unlike the manual burners, when the burners are equipped with outfire controls, no fuel flows to the burners when the main solenoid shutoff valve is closed.

Burner Operation with Outfire Controls

1. Turn the POWER switches ON.
2. Open the dampers in the exhaust stacks.
3. Ensure that the main burner control valve is closed and that the bleeder valves for both burners are turned fully clockwise.



IMPORTANT

It is recommended that two people be involved in lighting the burners. One person should hold the torch while the other person opens the valves and holds the push button in.

4. Open the main fuel supply valve at the tank. No fuel will be flowing at this point.
5. You must hold the push button in while lighting the burners.
6. As soon as the low fire is established at the inner burner, open the positive shutoff valve to the outside burner and light the outside burner on low fire.
7. After 30 to 40 seconds, release the push button and observe the pressure gage. If the pressure starts to drop rapidly, depress the push button and hold it in for another 30 seconds. It may require a slight increase in fuel to the outside burner to adequately heat the thermocouple. Once both of the thermocouples are heated the push button can be released.



IMPORTANT

In order to activate the thermocouples, both burners must be lit on low flame even if only one burner will be used for heating. Place the ignition torch at the inside burner nozzle and depress the push button in the outfire control box. Continue to hold the push button in until both burners are lit.

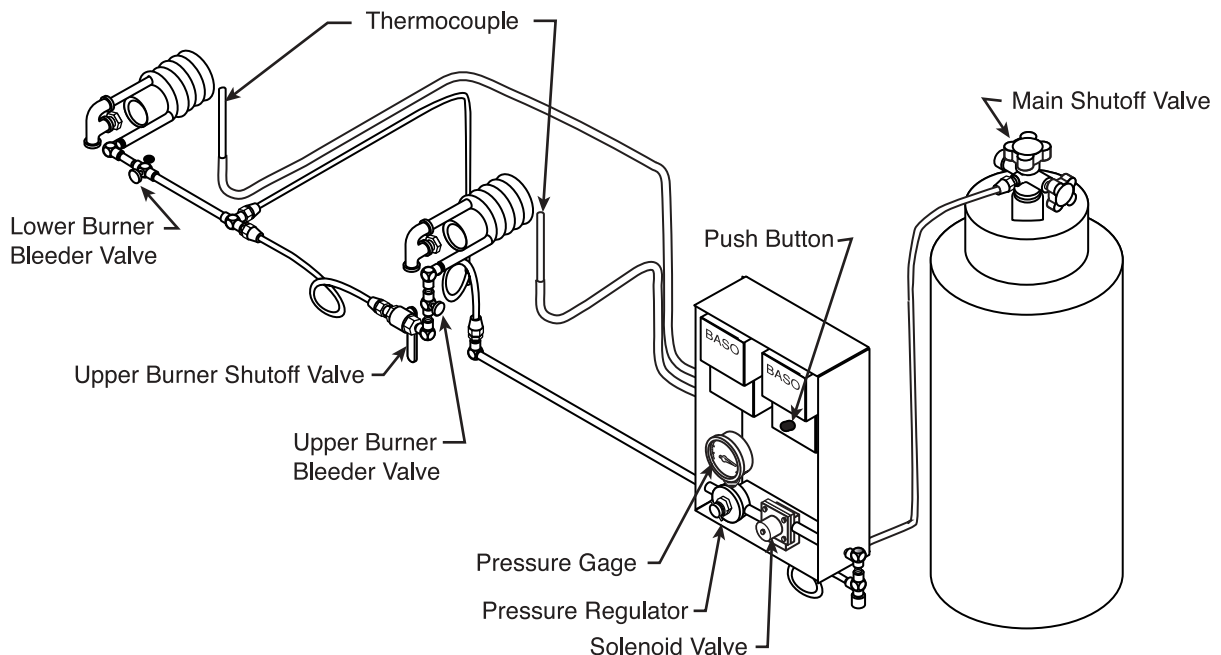

Figure 24. Outfire Controlled Burner System.

8. If both burners are to be used for heating, you can now open both bleeder valves. If only the inside burner is to be used for heating, open the bleeder valve on the inside burner and allow the outside burner to remain burning on low flame so the thermocouple will be heated. Remember, if either burner flame goes out, the outfire control will shut the solenoid valve cutting the fuel off to both burners.

 **WARNING**

A fully charged dry chemical type fire extinguisher must be within easy reach whenever the burners are operating or there is an open flame near the Distributor. Minimum dry chemical capacity of the fire extinguisher should be 10 pounds.

 **WARNING**

When heating, temperatures within the tank can vary. Shut the burners off when the thermometer reaches a reading 10 °F lower than the desired temperature. Continue to circulate & monitor temperature until the temperature stabilizes. Add remaining heat by operating burners for short periods, monitoring stabilized temperature after each period.

 **IMPORTANT**

Calibration of thermometers should be verified to be within + 2% of full scale reading annually.

Certification can be accomplished by a qualified laboratory or by comparing stabilized dial readings to the pencil thermometer reading. Replace any thermometer that does not meet the +2% accuracy requirement.

When the desired product temperature is reached:

1. Close the main fuel supply valve at the tank.
2. After all the fuel is burned and there is no flame at either burner, turn both bleeder valves fully clockwise and close the positive cut off valve at the burners.
3. Close the exhaust stack dampers to prevent heat loss.

Burners with Automatic Ignition and Temperature Limiting Control

Equipment Description

The temperature limiting control box contains the temperature limiting control components as well as the automatic ignition circuitry.

The automatic ignition circuit consists of two 12V coils, two spark plugs, a pair of thermocouples, (one at each burner), and a momentary push button switch. The 12V coils send high voltage to the spark plugs that causes sparks to arc intermittently at each pilot burner whenever there is fuel pressure in the line from the main supply tank. The thermocouples provide a signal that indicates when there is a flame at the pilot burners. The momentary push button switch on the control box is used to fire the main burners once the pilot burners have ignited and the thermocouples have been heated sufficiently.

The temperature limiting control circuit consists of a temperature probe in the Distributor tank that senses the asphalt temperature, a thermostatic switch in the control box and a temperature adjustment dial on the face of the control box. When the temperature of the asphalt in the Distributor is heated to the temperature selected with the temperature adjustment dial, the thermostatic switch shuts down the burners.

Burner Operation with Auto Ignition & Temperature Control

1. Open the dampers on the exhaust stacks.
Ensure that all burner valves are closed. With this type of control, the inside or lower burner may be operated without opening the positive shut off valve to the outside burner. If both burners are to be used, the positive shutoff valve should be opened.
2. Open the main fuel valve at the supply tank.
The spark plugs will begin to arc and will ignite the pilot burners.
3. Set the thermostat to the desired temperature.
4. Allow the pilot burners to heat the thermocouple probes for at least 2 minutes. When the pilot burners have heated the thermocouples sufficiently the sparker will stop. Press the cycle button to fire the main burners. The bleeder valves may then be opened. (Spark ignition will run while the burner is in operation.)
5. On new or rebuilt units, monitor the product thermometer to make certain that the burners shut down when the desired temperature is reached (as set on the temperature adjustment dial). If the burners do not shut down at the correct temperature, calibrate the thermostat.
6. Once the burner shuts off automatically, it will not restart until the cycle button is again depressed.

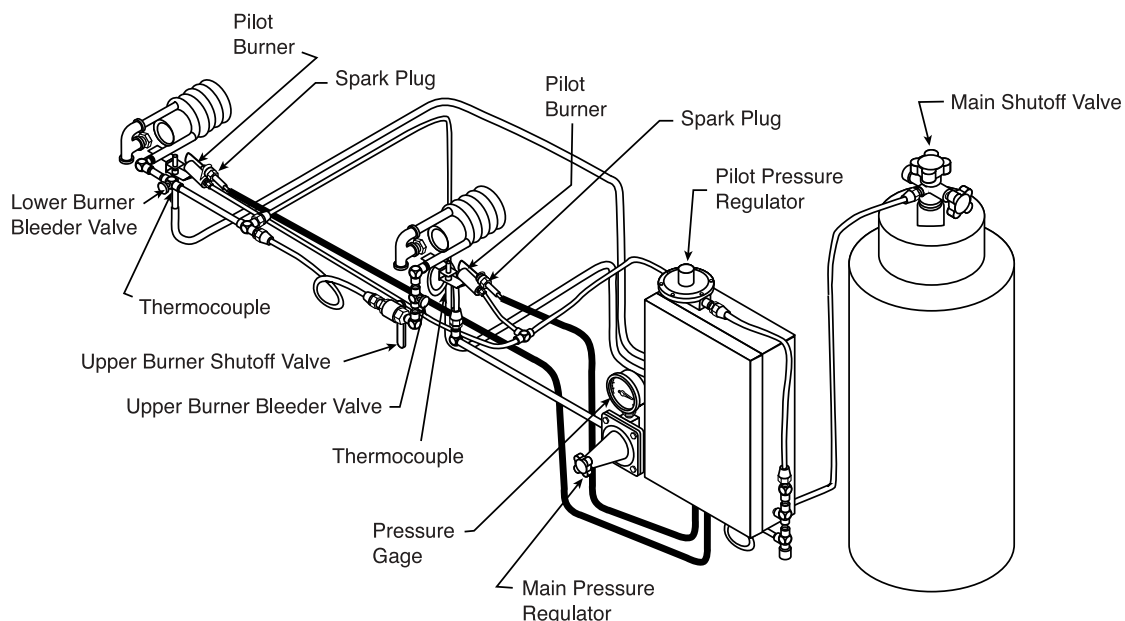

Figure 25. Burner System with Auto Ignition and Temperature Control.

7. To shut the system down, close the main fuel supply valve at the tank.
8. Increase the thermostat setting 50 to 75 °F higher and push the start button. This will bring on the main burners and quickly burn off all of the fuel in the line between the tank and the control box. The pilot burners may continue to burn for a short time after the main burners cut off. Do not draw material from the tank as long as there is a flame present.
9. Close the exhaust stack dampers.

Electric Driven Burner Diesel Operation

1. Open the dampers in the exhaust stacks.
2. To light the burner, turn on the LOWER BURNER switch.
3. If upper burner operation is desired, turn on the UPPER BURNER switch.
4. Do not heat the material higher than the spraying temperature recommended by the asphalt supplier.
5. To shut down the burners, turn off the burner power switches.

WARNING

Flues MUST be covered by a minimum of 6 inches of material when burners are in operation.

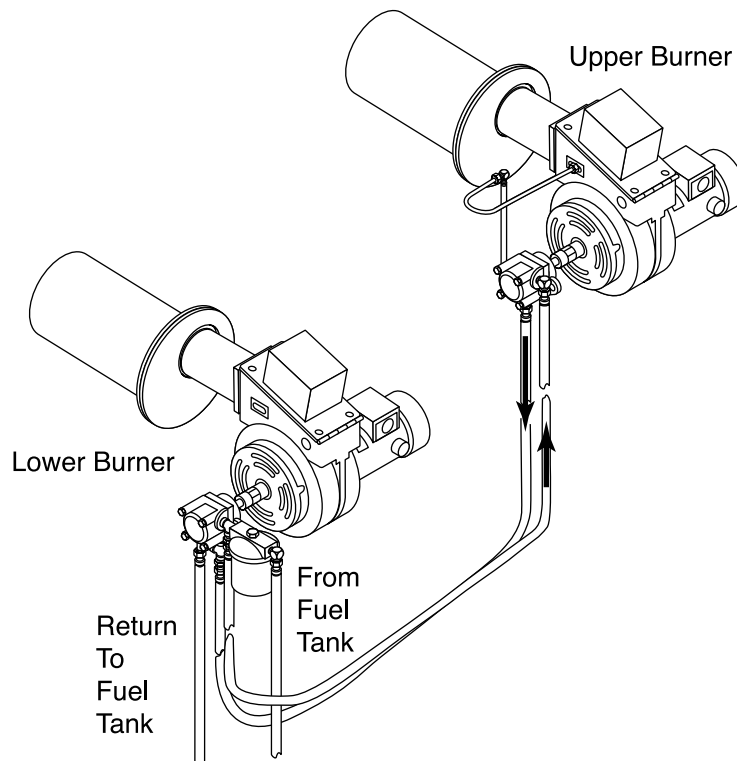

Figure 26. Electric Burner System.

Troubleshooting

Problem	Cause	Remedy
Spray Fogs	Pump speed too fast for size of nozzle.	Lower pump speed or change nozzles.
Spray Streaks	Pump speed too slow.	Increase pump speed.
	Nozzles not at proper angle.	Adjust angle of nozzles.
	Spray bar at improper height above ground.	Adjust spray bar height.
	Material temperature too low.	Heat material to correct temperature.
Spray Lacks Pressure	Pump speed too slow.	Adjust pump speed.
	One or more control valves in incorrect position, not fully opened or closed, or leaking.	Check position of all control valves. Be sure all valves are fully opened or closed. Repair leaking valves as necessary.
	Suction strainer plugged.	Clean suction strainer.
All Nozzles Do Not Cut Off Spray	Spray bar linkages not adjusted correctly.	Adjust linkage.
Pump Will Not Turn Or Turns Slowly	Material in tank or pump below pumping temperature.	Heat material to proper pump temperature.
	Air leak in suction line from reservoir to filter to inlet of charge pump.	Locate and repair leak.
	Hydraulic system pressure low.	Raise pressure.
	Low oil in hydraulic reservoir.	Add hydraulic oil to correct level.
	Spray bar valves set improperly.	Correct spray bar valve settings.
	Defective Hyd. motor.	Check for excessive case drain in motor.
Hydraulic Oil Overheats	Material in tank or pump below pumping temperature.	Heat material to proper pump temperature.
	Air leak in suction line from reservoir to filter to inlet of charge pump.	Locate and repair leak.
	Low oil in hydraulic reservoir.	Add hydraulic oil to correct level.
	Spray bar valves set improperly.	Correct spray bar valve settings.
Spray Bar Supply Tube Ball Joints Leak	Ball joint O-ring is loose.	Replace ball joint O-ring.
Application Rate Varies	Quantity of material in tank not being measured accurately.	Use Etnyre measuring stick for accurate readings. Be sure tank is level when measuring.
	Suction strainer plugged.	Clean suction strainer regularly.
	Hydrostatic controls not firmly positioned.	Ensure that all controls are firmly locked in place.
	Suck back valves not fully closed.	Ensure valve is closed.

Maintenance

Electrode Assembly Adjustments

1. Adjust electrode assembly per Figure 27.

NOTE: Before installing electrode assembly, check that blower wheel turns freely and that all set screws are tightened securely.

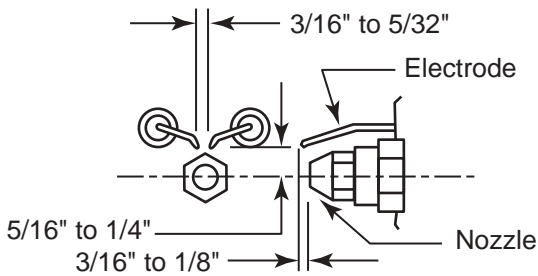
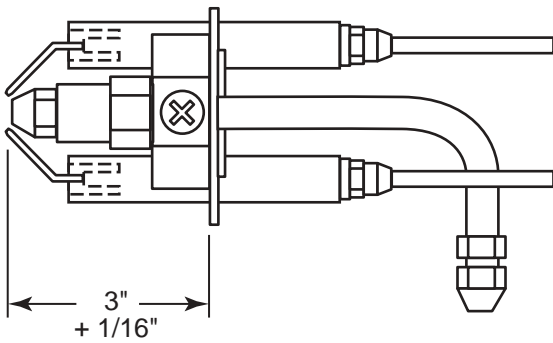

Figure 27. Burner Electrode Adjustments.

2. Install electrode assembly into air tube unit. Use escutcheon plate for mounting.

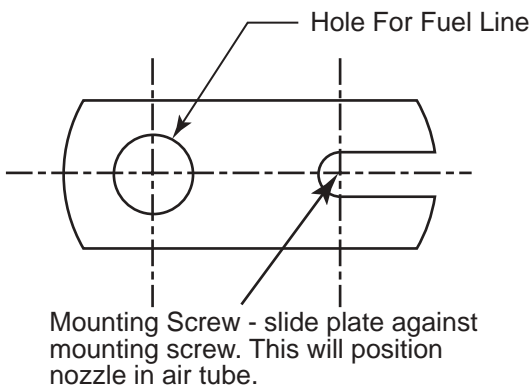

Figure 28. Electrode Assembly Installation

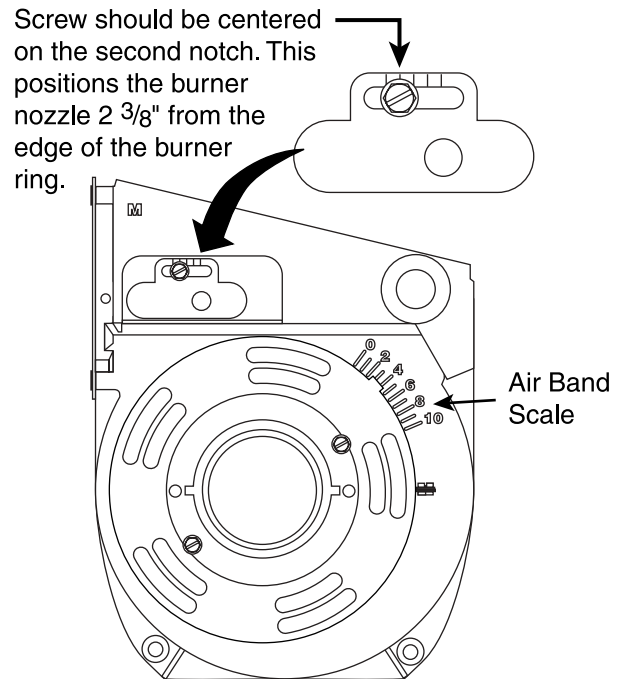

Figure 29. Nozzle Adjustment.

Burner Air Band Settings

1. Close bulk air bank (outside diameter band).
2. Set end air band between 3.5 - 4.0 on scale (see Figure 29).
3. Open covers or dampers on exhaust stacks.

! WARNING

To prevent an explosion or fire hazard, keep area free of sparks or open flames when testing burners.

Check Ignition Transformer Spark

1. Turn on power switch in rear control box.
2. Turn the BURNER switches on.
3. Hold an insulated screwdriver touching one of the springs and approximately 3/4 inches above the other spring on the transformer. It should be possible to jump a spark across the 3/4 inch gap between the spring and the screwdriver. If unable to generate a blue spark across this gap, check the voltage at terminal spades of the 12 volt ignition control box. Voltage must be 12 VDC minimum. If voltage is incorrect or not present, check ground wiring.
4. Reposition ignition transformer and secure to burner housing.

Fire Burners

1. Ensure that fuel oil pressure is 125 PSIG.
2. Turn the burner switch on.
3. Run the burner for 15 seconds maximum after lighting, then shut down.



WARNING

To prevent an explosion or fire hazard, flues must be covered by minimum 6 inches of material when burners are in operation. When testing burners, do not run burners for more than 15 seconds if tank is empty.

Replacing Speed Pickup

1. Loosen locknut and remove old speed pickup.
2. Turn in the new speed pickup clockwise by hand until the bottom end gently touches the internal speed ring.
3. Back it out counter clockwise 1/2 to 3/4 turn.
4. Using a 1/2 inch wrench to hold the speed pickup, torque the locknut to 10 lb-ft (13 Nm) with an 11/16 inch wrench.

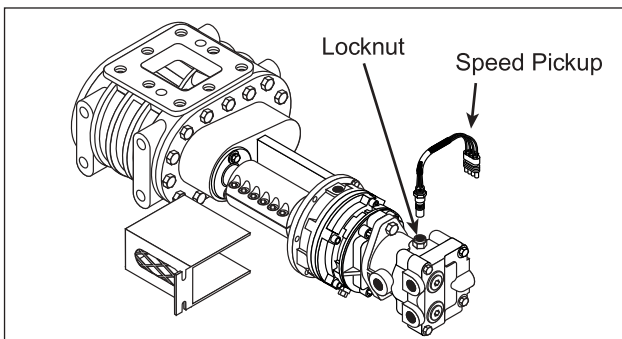

Figure 30. Hydraulic Motor.

Adjusting Spray Bar Nozzle Angle

Adjust nozzles to obtain an angle of approximately 30° with bar center line (see Figure 31). Every nozzle should be at the same angle.

NOTE: A nozzle adjustment wrench is supplied in the tool box of each new unit.

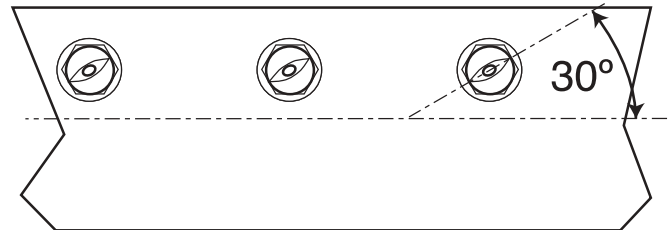

Figure 31. Nozzle Angle Adjustment.

Adjusting Spray Bar Height

Lower spray bar and adjust so that nozzles are approximately 12" above road when tank is empty. At this height spray fans will overlap to provide triple lap coverage. See Figure 32.

NOTE: Under heavy wind conditions it may be necessary to lower spray bar further.

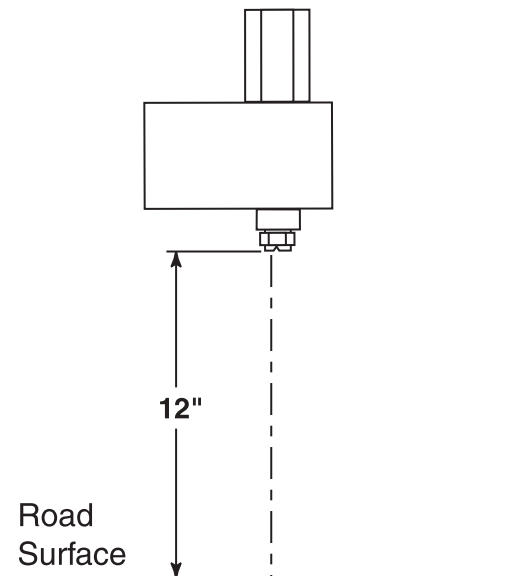

Figure 32. Nozzle Height Adjustment.

Servicing the Etnyre P-15 Pump

Vacuum Check

1. Flush pump with 3 quarts of diesel fuel through fill line.
2. Set controls for loading operation.
3. Install vacuum gauge in fill line cap.
4. Operate pump at 140 GPM on pump tachometer. A vacuum reading of less than 5 inches Hg. (inches of mercury) after 2 minutes of operation indicates a vacuum leak or a worn pump.

Pump Disassembly And Inspection

1. Remove 20 capscrews from perimeter of pump end plate (see Figure 33).
2. Install two capscrews in the threaded holes near the outer edge of the end plate at approximately the 5 o'clock and 11 o'clock positions. Tighten the capscrews evenly to force the endplate away from the pump body.
3. Remove the endplate, impeller shafts and impellers (gears) as an assembly.
4. Clean the interior of the pump case. Slide your fingers across the interior surfaces of the case. If a narrow raised area can be felt midway between the front and the rear of the case, the entire pump should be replaced.
5. If there is no raised area, measure the bore of the case at its widest point horizontally (side-to-side). This measurement must not exceed 9.910 inches.

6. Next, measure the case bore vertically at a point 2.8 inches from each side. The vertical measurement must not exceed 5.660 inches. If any bore measurements exceed these limits, the entire pump must be replaced.
7. If inspection indicates the pump case is acceptable, measure the outside diameter of the impeller gears. Measure the impeller gears from tooth point to tooth point on teeth directly opposite each other. The minimum outside diameter of the gears should be 5.635 inches. The minimum length of the gears should be 3.628 inches.
8. If any impeller gear is undersize, the entire four-gear set must be replaced.
9. End plate gasket thickness should be 0.014 to 0.016 inches.
10. Divider plate thickness should be 0.127 to 0.128 inches.

Impeller Installation And Pump Assembly

Each impeller gear set uses a series of dots on the gear faces to indicate position of the gears within the pump. Refer to Figure 33 for proper positioning of the gears. The dots must face away from the divider plate (towards the ends of the pump). Install the impellers in numerical order.

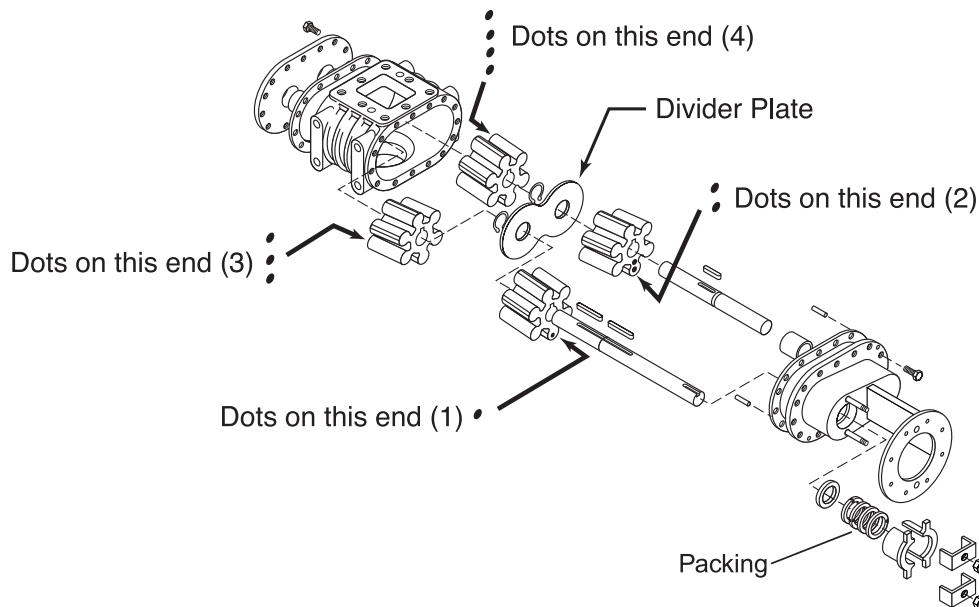

Figure 33. Etnyre Asphalt Pump.

General Fuel Data and Heating Terminology

Fuel Data

Fuel	Weight Per Gallon	BTU Content
#2 Fuel Oil	7.49 lbs	144,300 per gallon
Kerosene	6.97 lbs.	134,500 per gallon
Propane	4.20 lbs.	91,500 per gallon

Approximate Burner Fuel Consumption

Low Pressure Fuel Oil

935,000 BTU @ PSI
6.5 GPH per burner
(144,000 BTU per gallon)

Kerosene Generating

575,000 BTU @ 40 PSI
4.25 GPH per burner
(135,000 BTU per gallon)

Heating Terminology

Flash Point (Open Cup)

The temperature at which a flammable liquid in an open container emits vapor that will flash when exposed to a direct flame. This temperature is lower than required for the liquid mass to ignite.

Closed Flash Point

The temperature at which a flammable liquid in a closed container emits a vapor that will flash when exposed to a direct flame. This temperature is lower than required for the liquid mass to ignite. The closed flash point is generally 30°F lower than the open cup flash point.

Fire Point

The temperature at which a flammable liquid emits a vapor at a rate that will continue to burn after it has flashed.

Ignition Temperature (Kindling Temperature)

The lowest temperature at which a combustible material will continue to burn once ignited.

Convection

Heat transfer by a flow of a liquid or gas over a solid material. Example: Flues in asphalt tank are heated from hot gases passing through them, or, heat transfer coils in tank are heated from steam or hot oil passing through them.

Conduction

Heat transfer through a solid mass by direct molecular contact. Example: Heat applied only to one end of a metal rod will be transferred throughout the entire body by molecular transfer.

Hydraulic Fluid Requirements

General Information

The ability of a hydrostatic transmission to maintain desired performance for the expected life depends on the quality of fluid being circulated in the units. Fluid quality can be measured in three general categories: lubricity, contaminants, and temperature. Obtaining satisfactory values in these three areas depends on the fluid and the circuit in which it is used.

Etnyre field service experience indicates that most transmission failures result from a breakdown of fluid quality. Primary causes are solid particle contamination and overheating. Water or oil in the fluids are also significant contributors. These problems are usually the result of poor maintenance. Sometimes fluid selection can lessen the impact of unusual environmental factors.

Hydraulic Fluid Requirements

The catalog ratings and performance data are based on operating with good quality petroleum based fluids. Premium hydraulic fluids containing high quality rust, oxidation and foam inhibitors are required. These include premium turbine oils, API CD engine oils per SAE J183, M2C33F or G automatic transmission fluid (Type F), power shift transmission fluids meeting Allison® C-3 or Caterpillar® TO-2, and certain specialty agricultural tractor fluids.

Although fluids containing anti-wear additives are not necessary for satisfactory performance, when used, the fluids must possess good thermal and hydrolytic stability to prevent wear, erosion and corrosion of the internal components.

Where water contamination is likely due to condensation, operation in a damp environment or frequent splashing, a fluid with outstanding hydrolytic stability is recommended. Consult the Etnyre Service Department for recommendations for these fluids. Avoiding the use of Dexron® II transmission fluids which *do not* meet Allison C-3 specification is recommended.

Viscosity & Temperature Requirements

The fluid must have sufficient viscosity to maintain an oil film at the bearing surfaces. This depends on fluid selection and on operating temperature. Recommended viscosity for best life and efficiency, and minimum for intermittent and continuous operation is listed below.

Fluid Viscosity Limits For Petroleum Based Fluids	
Maximum Continuous SUS (cSt)	500 (110)
Optimum Viscosity SUS (cSt)	70 (13)
Minimum Continuous SUS (cSt)	55 (9.0)
Minimum Intermittent SUS (cSt)	47 (6.4)

Viscosity index improved (multi-viscosity) fluids may noticeably shear down in service when used in hydrostatic transmissions. This will lower the operating viscosity below the originally specified value. The lowest expected viscosity must be used when selecting fluids. Consult your fluid supplier for details on viscosity sheardown.

Fluid temperature affects the viscosity of the fluid and resulting lubricity and film thickness. High temperatures can also limit seal life, as most nonmetallic seals are adversely affected by use at elevated temperatures. Also, fluids may break down or oxidize at high temperatures, reducing their lubricity and the resulting life of the unit. Cavitation is more likely at high temperature. Recommended limits for operating temperatures are tabulated below.

Fluid Temperature Limits For Petroleum Based Fluids	
Continuous Limit	180°F
Intermittent Limit	220°F

These temperature limits apply at the hottest point in the transmission, which is normally the motor case drain.

Heat problems sometimes occur because of problems with one of the circuit components. A partially stuck relief valve will heat up the oil rapidly. Circuit components that have developed high internal leakage rates will contribute to heat generation.

Contamination Levels

Clean fluid implies the absence of impurities such as solid particles, water and air. Contamination control includes proper design, installation, and maintenance of hydraulic components.

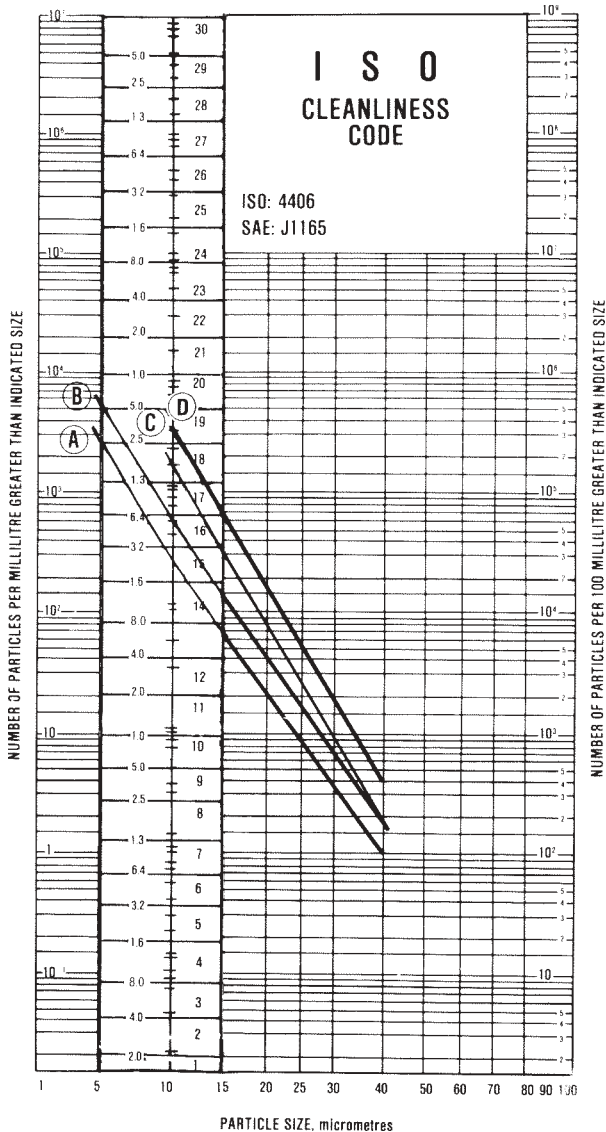

Curve A Desired limit for longer life (3500 PSI continuous system pressure)	Curve C Limit at machine ship and new fluid added to transmission
Curve B Continuous operating limit (2000 PSI continuous pressure) system	Curve D Limit at machine start up

Figure 34. Fluid Cleanliness Chart.

The reservoir is designed to limit entry of contamination during servicing and operation. A sealed reservoir with a low pressure relief valve reduces the introduction of contaminants while maintaining inlet and case drain pressures below the maximum recommended.

The purpose of the filter in a system is to clean the oil at initial start up and to maintain acceptable levels of particle contaminants as they are ingested or generated during operation of the system. Filtration is a matter of controlling the particle sizes and their respective quantities to appropriate levels so as to avoid degradation of the system components and thereby assure the desired life.

Fluid contaminant profile requirements for Etryre hydraulic units have been determined empirically based on measuring fluid quality in successful application, and in laboratory tests designed to evaluate hydraulic unit contaminant sensitivity. General contaminant levels have been developed based on this experience and are shown in Figure 32.

Acceptable contamination levels at machine start up for the system loop should be equal to or better than Curve D. The machine may be exercised to 500 psi but should not be worked (pressure over 500 psi) until the oil cleanliness meets or exceeds Curve C.

The machine should clean up during a relatively short period of normal operation to meet the oil cleanliness level of Curve A or Curve B. A system that meets Curve A will provide the user with a longer trouble free operating life than one that meets Curve B. The Curve A cleanliness level should be met in systems exceeding the continuous pressure limit for 1000 hours/years machine use.

Some control valves may require better contamination limits than specified in Figure 32. Controls with small area screens or low force level values may be susceptible to malfunction from contamination.

The contamination sensitivity of components generally increases with higher pressure, temperature or speed. A better fluid contaminant profile may be required for systems which operate near the extremes of their ratings. Short life or infrequent operation requirements may increase allowable contaminants.

The selection of a filter depends on a number of factors including the contaminant ingress rate, the generation of contaminants in the system, the required fluid cleanliness, and the desired maintenance interval. Filters are selected to meet the above requirements using rating parameters of efficiency and capacity.

Filter efficiency may be measured with a Beta ratio. For simple closed circuit transmissions with controlled reservoir ingress, a filter with a Beta ratio of 1.5 to 2 has been found to be satisfactory. For some open circuit systems, and closed systems with cylinders being supplied from the same reservoir, a considerably higher filter efficiency is recommended. This applies to systems with gears or clutches using a common reservoir. For these systems, Beta ratios of 10 or 20 are typically required.

The filter capacity required depends on the amount of contaminants ingressed and retained in the filter and the desired maintenance interval. As a rough guide, a capacity in grams equal to twice the charge flow in GPM has been found to be satisfactory for our systems.

Since each system is unique, the filtration requirements for that system will be unique and must be determined by test in each case. It is essential that monitoring be the final criteria for judging the adequacy of the filtration system.

Lubrication Chart

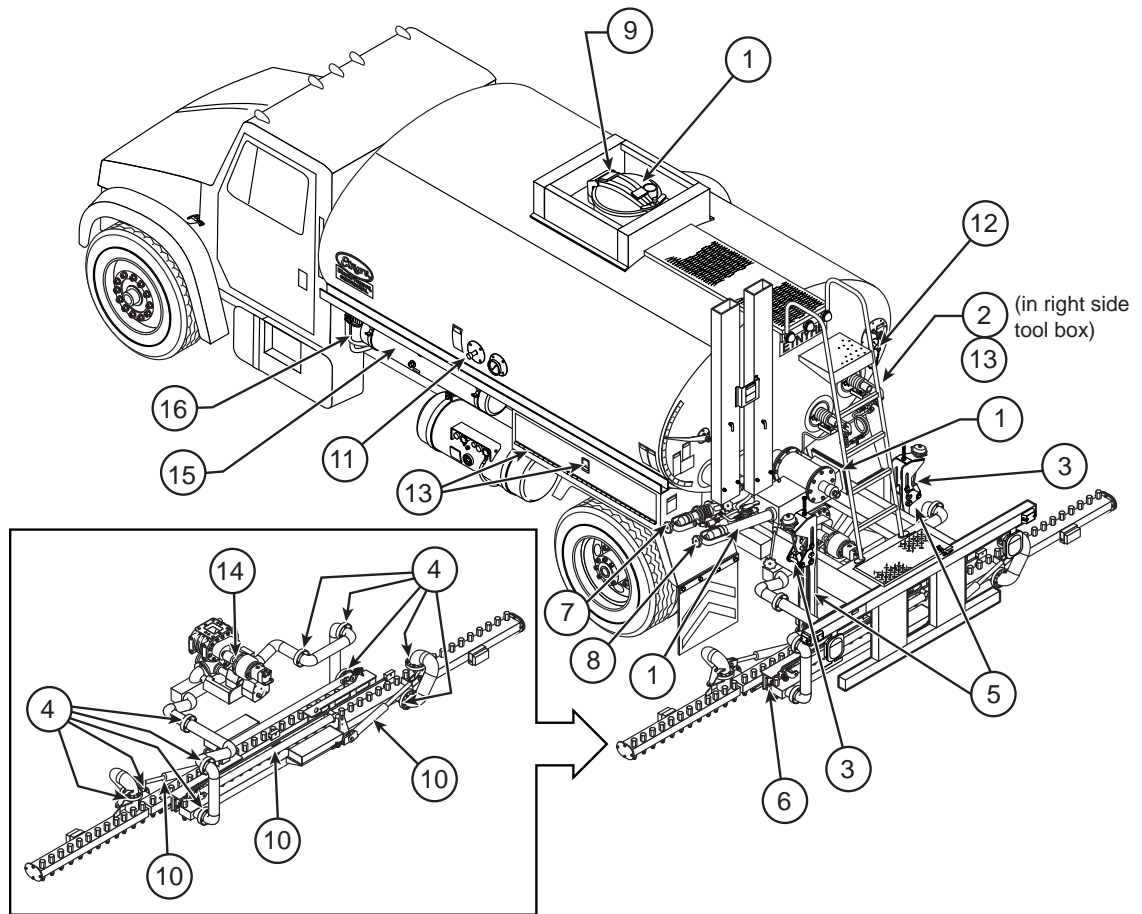

INTERVAL	POINT	IDENTIFICATION	LUBRICANT	QUANTITY
DAILY	1	Strainers (Fill Line, Manhole, Strainer Box)	Clean	—
WEEKLY	2	Air Oiler	EO	Fill
MONTHLY	3	Bar Latches	EO	Springly
	4	Swivels	MPG	Springly
	5	Bar Carry Mechanism	EO	Springly
	6	Bar Shoe Slide Plates	AS	Springly
	7	Transfer Line Cap	AS	Springly
	8	Load Line Cap	AS	Springly
	9	Manhole Lid	AS	Springly
	10	Exposed Hydraulic and Air Cylinder Rods	EO	Springly
	11	Thermometer Cap	AS	Springly
	12	Sample Valve Cap	AS	Springly
13	Tool Box Hinge and Latch	EO	Springly	
SERVICE	14	Pump Shaft Coupling	AS	Springly
	15	Hydraulic Reservoir	HTF	Fill to Top of Sight Glass
	16	Hydraulic Oil Filter	—	Replace when gauge is red

MPG: Multi Purpose Grease MIL-G-18458B-SH
 AS: Anti-Seize MIL-T-5544

EO: (Engine Oil) 10W MIL-L-2104-F
 HTF: Hydraulic Transmission Fluid - Type F

NOTE: Fill line oiler, located on outlet side of air reservoir, with light oil as needed. Also wipe cylinder rods clean and lightly oil. Drain water from air reservoir daily.

NOTE: Fill Hydraulic Tank completely for winter storage. This will prevent condensation in the reservoir. Drain down to thermometer hole prior to use.

Etnyre Spraybar Nozzles

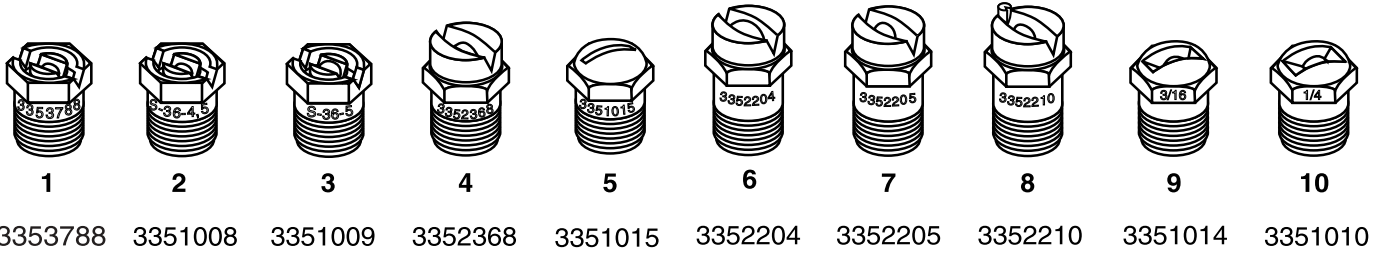

Ref.	Part No.	Description	Application Per Square Yard	Application (Metric) Liters Per Square Meter	Flow Gallons Per Minute Per Foot
1	3353788	V Slot Tack Nozzle	.05 – .20	.19 – .75	3.0 to 4.5
2	3351008	S36-4 V Slot	.10 – .35	.38 – 1.30	4.0 to 7.5
3	3351009	S36-5 V Slot	.18 – .45		7.0 to 10.0
4	3352368	Multi-Material V Slot	.15 – .40	.57 – 1.50	6.0 to 9.0
5	3351015	3/32" Coin Slot	.15 – .40	.57 – 1.50	6.0 to 9.0
6	3352204*	Multi-Material V Slot	.35 – .95	1.30 – 3.60	12.0 to 21.0
7	3352205*	Multi-Material V Slot	.20 – .55	.75 – 2.08	7.5 to 12.0
8	3352210	End Nozzle (3352205)	.20 – .55	.75 – 2.08	7.5 to 12.0
9	3351014	3/16" Coin Slot	.35 – .95	1.30 – 3.60	12.0 to 21.0
10	3351010	1/4" Coin Slot	.40 – 1.10	1.50 – 4.16	15.0 to 24.0

* Recommended nozzles for seal and chip with emulsified asphalts.

Serial Number Plate Location

The Serial Number Plate is a brass plate located on the left side of the vehicle toolbox. Generally, the serial number has a letter prefix followed by four numbers.

The unit serial number is also stamped on the left front tank mounting leg.

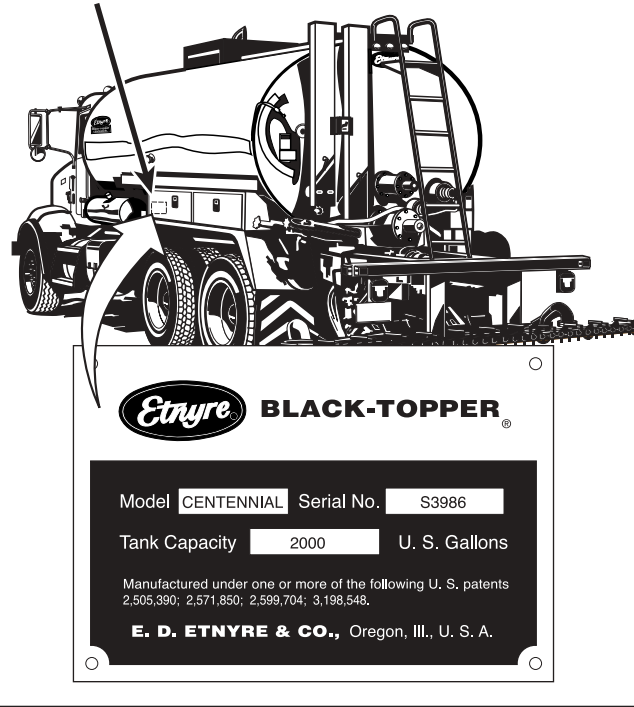

Figure 35. Serial Number Plate Location.

Decimal Equivalent Chart

Fraction	Decimal	Fraction	Decimal
1/16	.06	9/19	.56
1/8	.12	5/8	.62
3/16	.19	11/16	.69
1/4	.25	3/4	.75
5/16	.31	13/16	.81
3/8	.38	7/8	.88
7/16	.44	15/16	.94
1/2	.50	1	1.00



Something Wrong with this manual?

If you find inaccurate or confusing information in this manual, or just have a suggestion for improvement, please let us know.

Mail or FAX this form to us at: E. D. ETNYRE & CO. 1333 S. Daysville Rd. Oregon, Illinois 61061 • Fax: 800-521-1107 • www.etnyre.com

Attn: Service Manager

Recommended changes from: _____

Address _____

City, State, Zip _____

Phone _____

Date Sent _____

Manual Number (upper right corner of front cover) _____

Manual Title _____

Explain the problem in the space below.

Page Number	Reference Number	Paragraph Number	Figure Number	Problem (please be specific)

M-114-08

Serial Number S3985 and up

For Units with Variable Width Spray Bar



**Black-Topper® CENTENNIAL
Asphalt Distributor
With BT 1 Controls**



Operation



Maintenance



Safety



E.D. ETNYRE & CO. – 1333 S. Daysville Road – Oregon, Illinois 61061

Phone: 815-732-2116 or 800-995-2116 – Fax: 800-521-1107 – www.etnyre.com