



A-142-22

# Etnyre Black-Topper™

Asphalt Distributor





# Prime - Tack - Seal

Asphalt distributors are used by both contractors and municipalities. Most are used to do the following two functions:

1. Tack coat road surface in front of a hot mix paver.

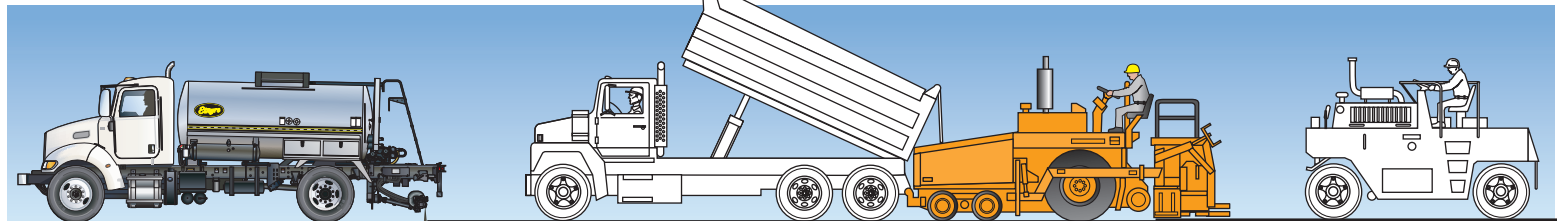

2. Spray a metered and controlled amount of liquid asphalt in front of a self propelled chip spreader in a chip seal road construction or maintenance program.

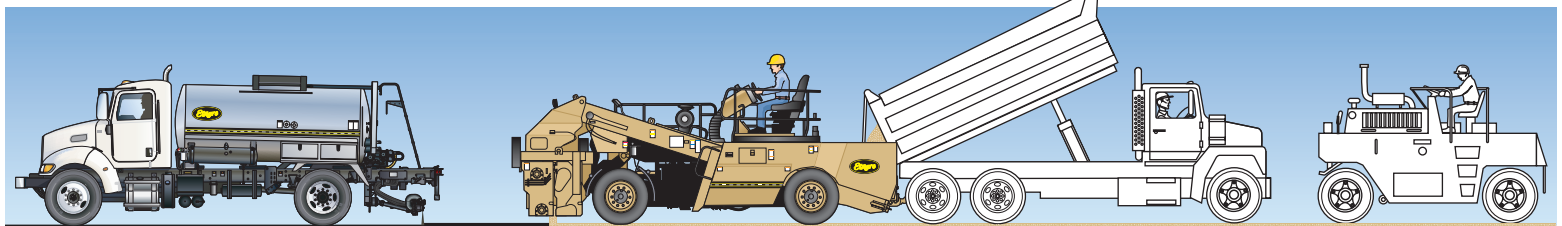

It is important that an asphalt distributor be designed and have features to service both of these markets.

**With this in mind, let's design an ideal distributor.**

**The one thing that you should keep uppermost in your mind when designing a distributor is:**

Hot bituminous material will congeal as it cools.

**We want the shortest possible distance between tank and spray bar.**

Asphalt products are handled at many different temperatures (70°F - 380°F) and have different characteristics subject to the refining process and after market modifications. There are three basic types of asphalt: Asphalt Cement (AC), Cut Backs (SC, MC, RC) and Emulsions. Knowledge of the asphalt products is extremely important for a safe and productive use of the distributor.

# Designing the Ideal Asphalt Distributor

**An asphalt distributor is composed of eight major components.**

1. Tank
2. Heating System
3. Asphalt Pump and Circulating System
4. Spray Bar
5. Flushing and Clean-out System
6. Power
7. Application Control and Metering
8. Chassis

**The distributor needs to perform nine basic functions.**

1. Fill the tank.
2. Heat material in tank.
3. Circulate material in tank.
4. Circulate material in spray bar.
5. Spray a metered amount of material.
6. Handspray.
7. Suck-back material from spray bar.
8. Wash out.
9. Transfer / unload.



# Distributor Construction

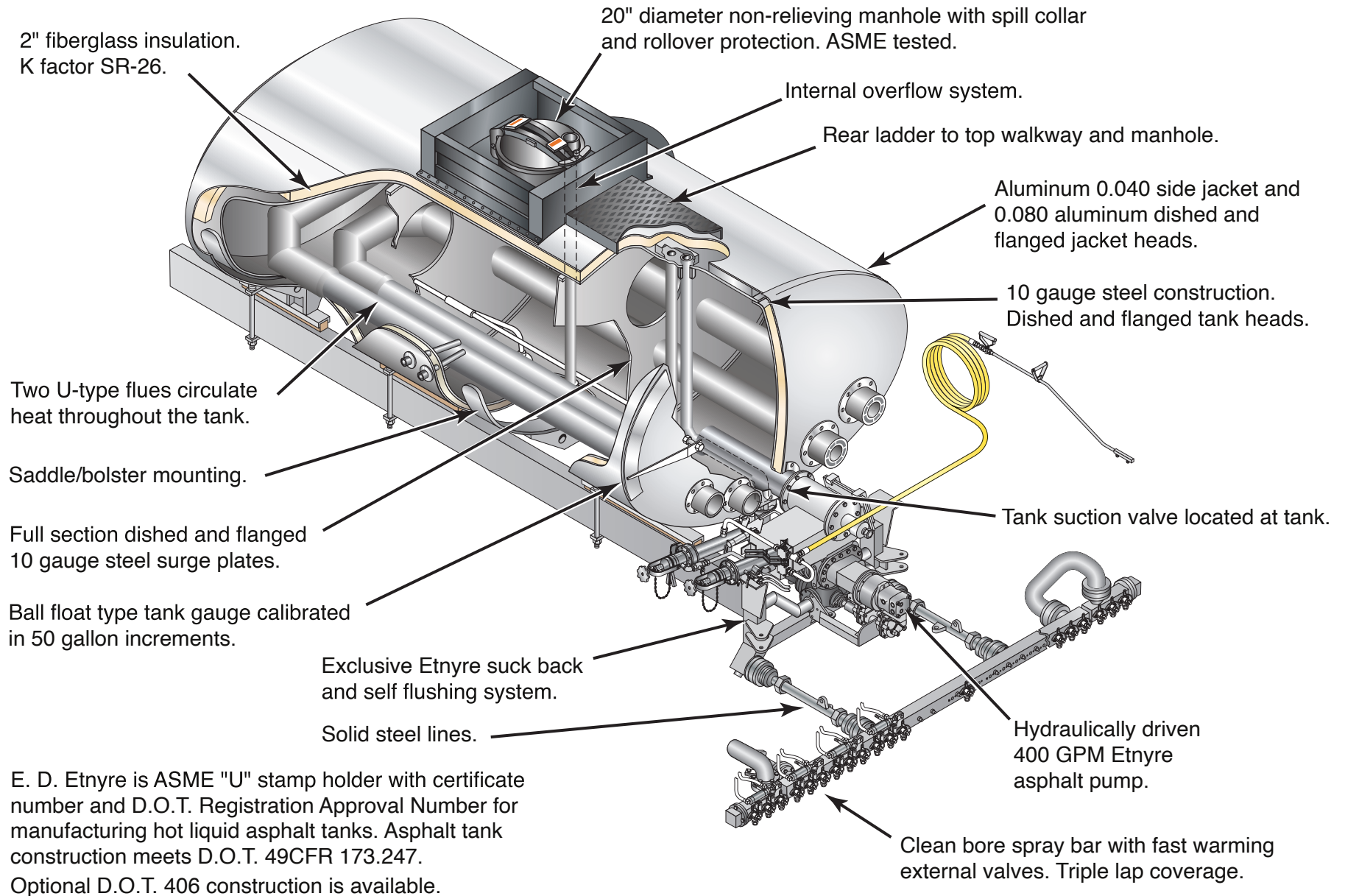

E. D. Etnyre is ASME "U" stamp holder with certificate number and D.O.T. Registration Approval Number for manufacturing hot liquid asphalt tanks. Asphalt tank construction meets D.O.T. 49CFR 173.247. Optional D.O.T. 406 construction is available.

# Tank Construction

## Surge Plates and Heads

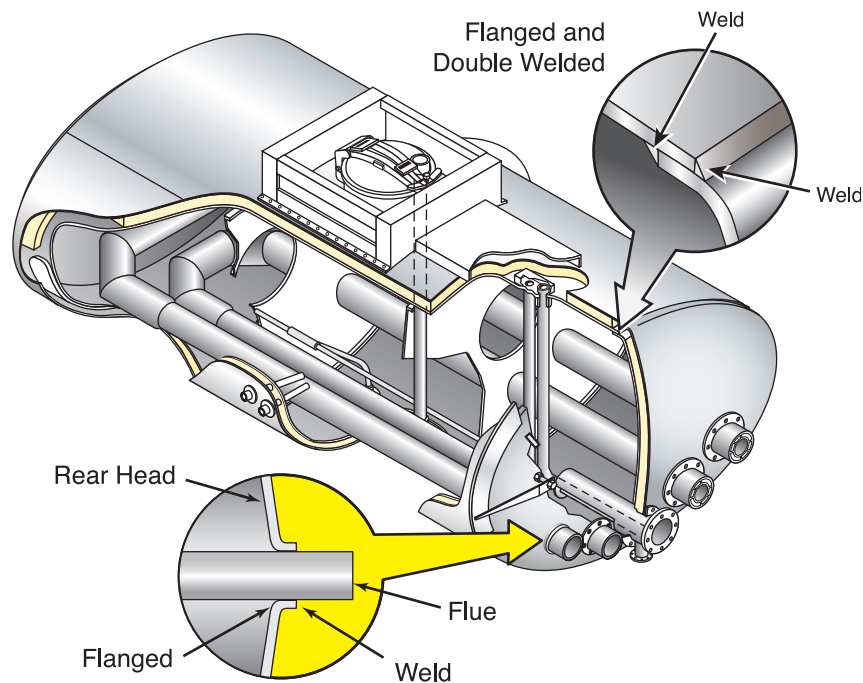

- All 10 gauge steel construction.
- Heads are deep dished, flanged and double welded inside and outside. Much stronger than flat heads.
- Pulled (flanged) holes for heat flues. Relieves weld stress.

- The tank must meet detailed Federal regulations.
- The tank should be designed to expand and contract due to hot products.
- The tank must breathe, have surge control and keep the product at the desired temperature.

## Saddle and Bolster Tank Mounting

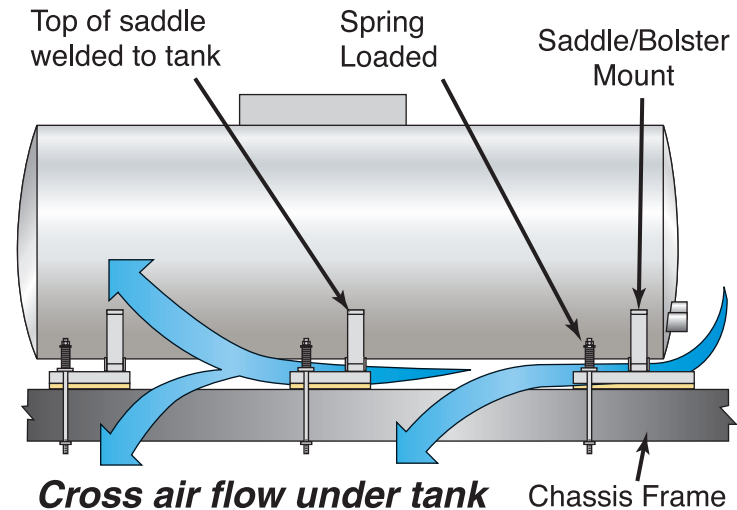

- Tank rests in the saddle/bolster mounting. Top of pad is welded to side of tank. Tank is free to move allowing expansion and contraction caused by hot products.
- Saddle mounting allows cross air movement between the bottom of the tank jacketing and truck frame. Asphalt fumes from the tank overflow are not trapped or channeled to the burners at rear.

## Tank Construction Continued

### Insulation and Jacketing

- Special 2" fiberglass insulation 1-1 lb. density.
- Aluminium .040 side jacket and aluminium .080 dished and flanged jacket heads.

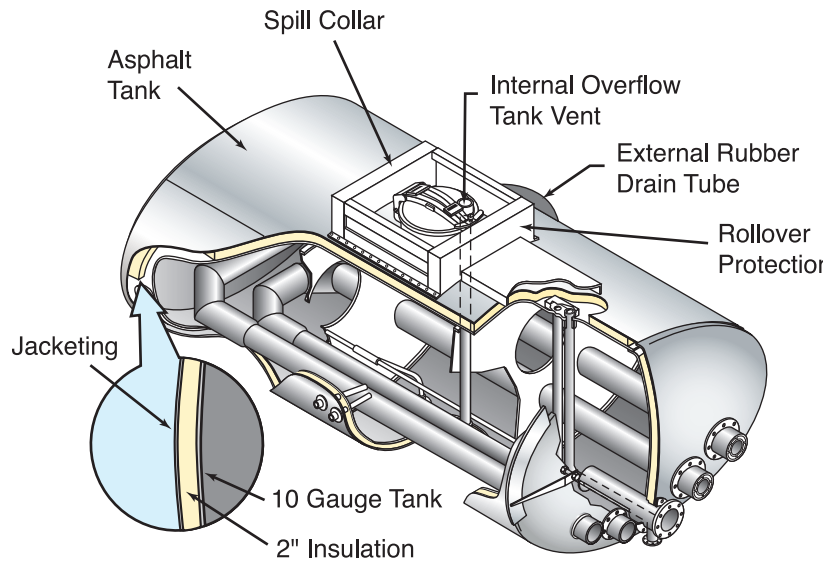

### Manhole and Ladder

- 20" diameter manhole assembly, including rollover protection to meet D.O.T. 49CFR 173.247.
- Spill collar with drain tube.
- Rear ladder and safety slip resistant aluminium walkway to manhole area.

### Tank Vent

- 3" diameter pipe for fast venting.
- Design allows overflow pipe to be 6" above top of tank extending into manhole lid to keep liquid asphalt from surging out into spill collar in normal distributor starting, stopping operation.
- Easy inspection for safety maintenance.

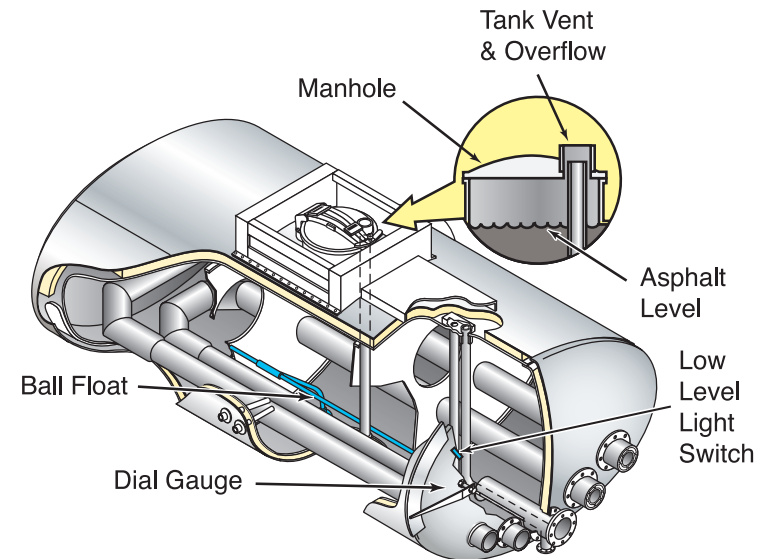

### Tank Gauge

- Float type, ball at center of tank.
- Easy to read rear mounted dial gauge.
- Dial visible from both cab and rear loading area.
- Includes low level indicator light in cab control panel.
- Gauge marked in 50 gallon increments.



# Tank and Accessories

## Tool Boxes on each side of unit

- All aluminum tool boxes on both sides of unit provide storage for tools and accessories.
- Tool boxes have hinged, aluminum side opening doors with flush type locks.

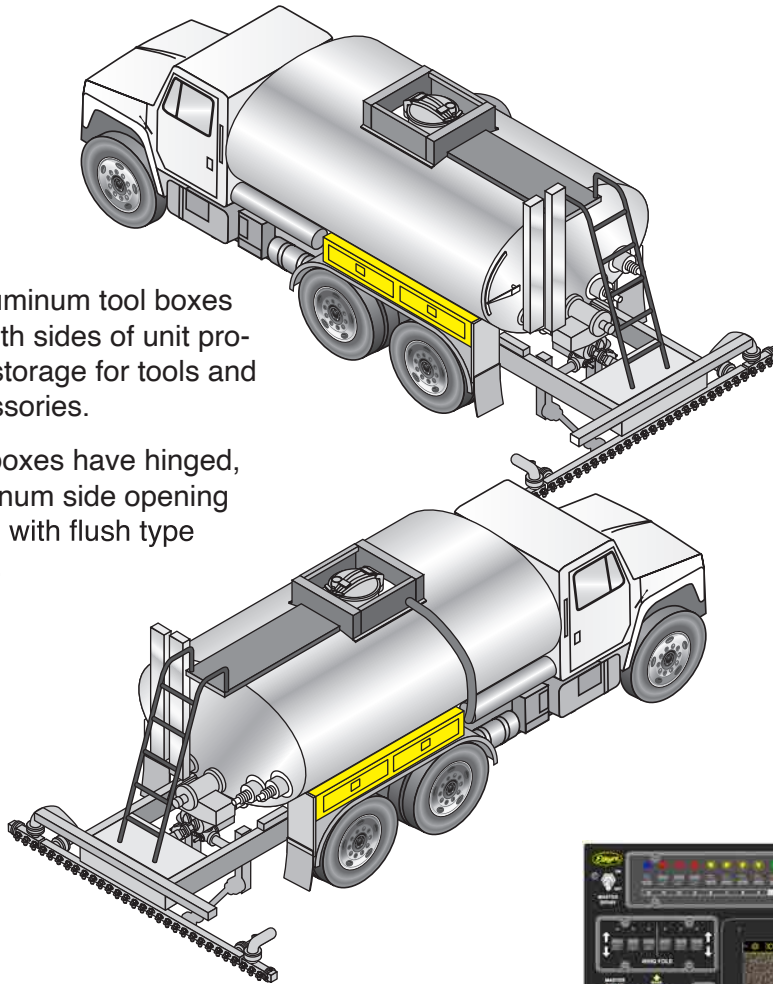

## Liquid Sampling Valve (standard feature)

- Allows liquid asphalt sample to be taken without opening manhole lid.
- 3/4" valve located in rear head under jacking.
- Self draining return to inside.
- May be needed to meet state D.O.T. requirements.

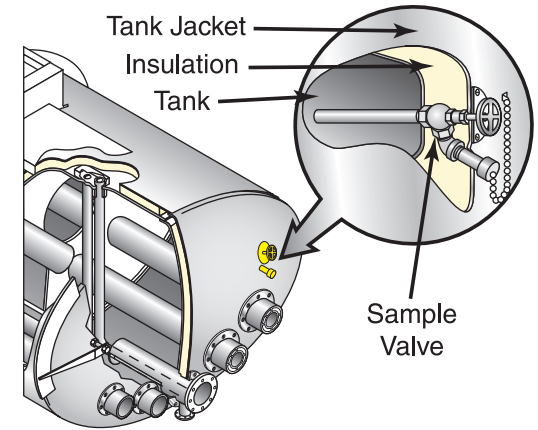

## Tank Thermometers

- Digital temperature readout (Standard).

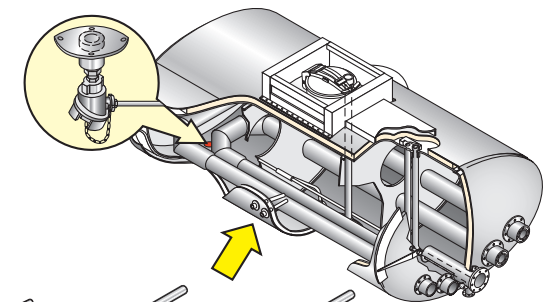

Pencil Type  
(Optional)

2" Dial Type  
(Standard)

4" Dial Type  
(Optional)

# Tank and Accessories continued

## Air-operated aluminum folding handrails & ladder



# Heating System

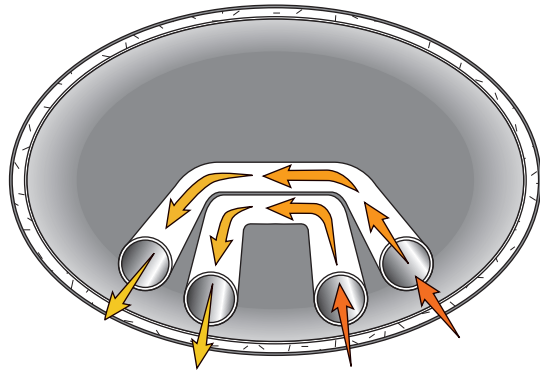

- One or two 8-in. inlet to 6-in. outlet U-type flues completely circulate burner heat throughout the tank.

- Above all the heating system must be designed for safe and efficient operation.
- The operator must be thoroughly trained before beginning the heating process.
- Different asphalt products are handled at different temperatures. Safe operation requires thorough knowledge of bituminous products.

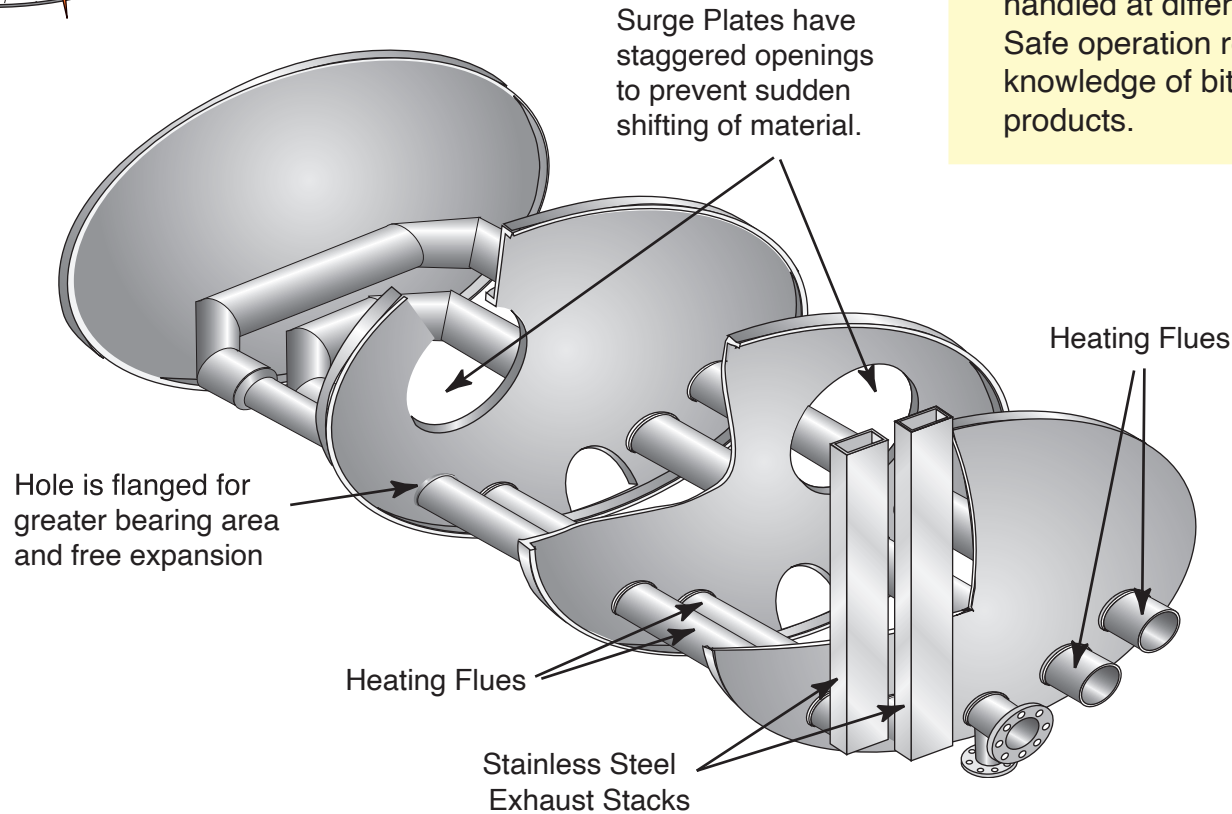

## Liquid Propane Gas (LPG) Burners

- 800,000 BTU's each burner.
- 52 gallon frame mounted tank.
- Thermostatically controlled shut down, outfire protection, travel lock out.

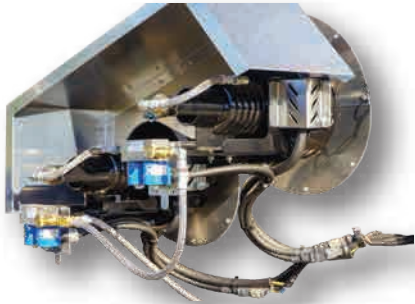

## 52 Gallon Frame Mounted LP Tank (for LPG Burners)



- Truck-Mounted LP Tank mounted to frame underneath cleaning solvent tank



- 52 Gal. LP Tank

## High Pressure Fuel Oil Burners

- 25 gallon fuel oil tank.
- Electric drive blower and fuel oil pump. Electric drive provides constant, safe operation
- Thermostatically controlled shut down, outfire protection, travel & low-level lock out.
- 428,000 BTU's

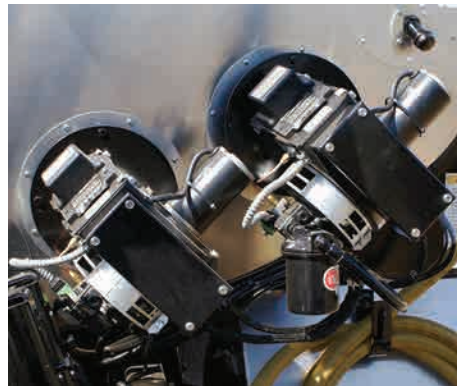

## Process Heat Tubes (optional)



# Electric Tank, Sump, Pump, Suck Back and Bar Heat 240V Single Phase

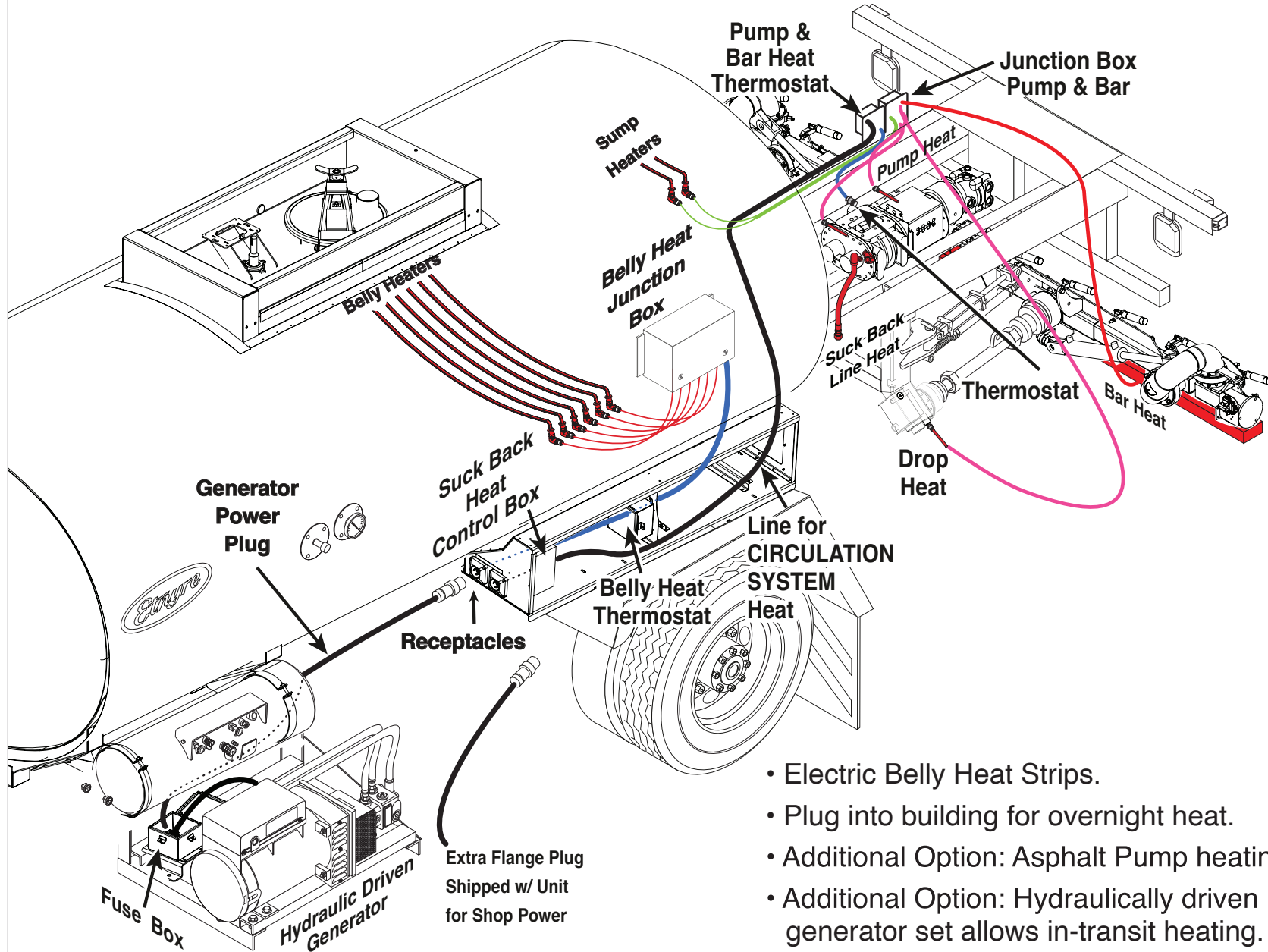

- Electric Belly Heat Strips.
- Plug into building for overnight heat.
- Additional Option: Asphalt Pump heating.
- Additional Option: Hydraulically driven generator set allows in-transit heating.

# Optional: Heat Chase from Truck Cooling System

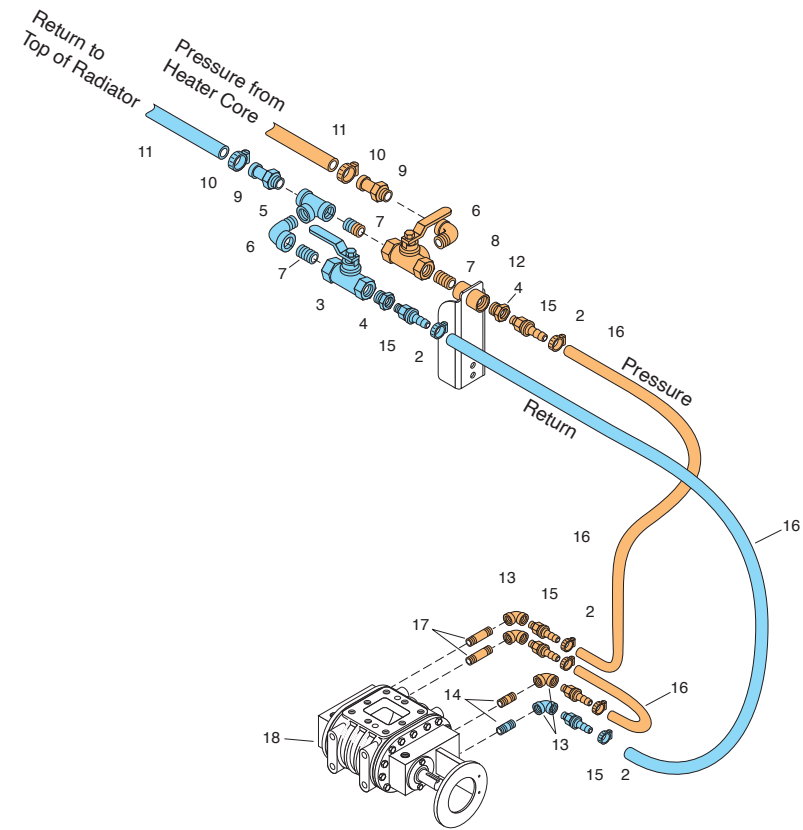
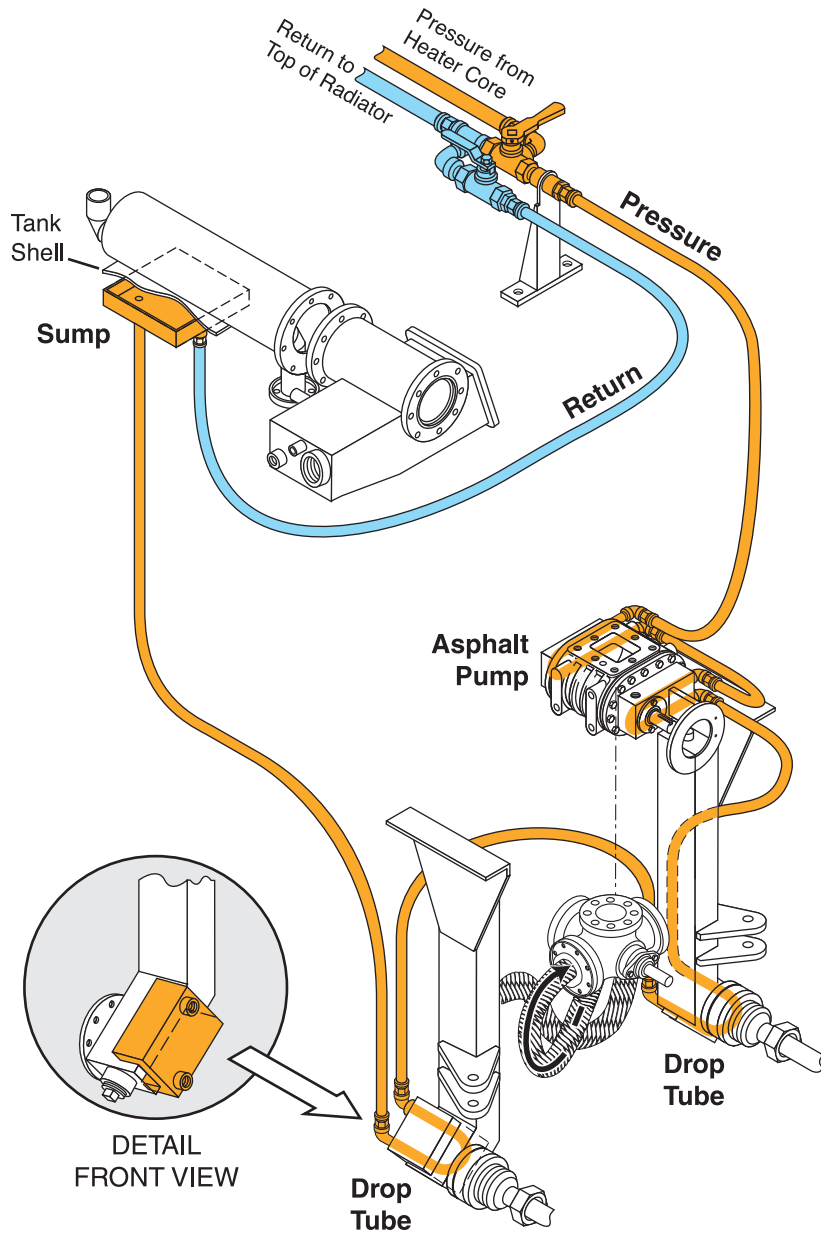

## Pump Only Diagram

- Truck engine coolant circulates through system warming pump and circulation system piping.
- Decreases start up problems on cold mornings.
- Decreases prep time on initial start ups.

Sump, Pump, and Drops

# Circulating System

- The Circulation System should be designed so that the shortest distance for the asphalt to travel is maintained.
- The Circulation System should be designed to suck back material from circulating system components so that a minimum amount of flushing fluid is required.
- The Circulation System controls the base functions and material flow, i.e.:
  - Fill
  - Circulate
  - Circulate in Bar
  - Spray
  - Suck Back
  - Flush
  - Transfer

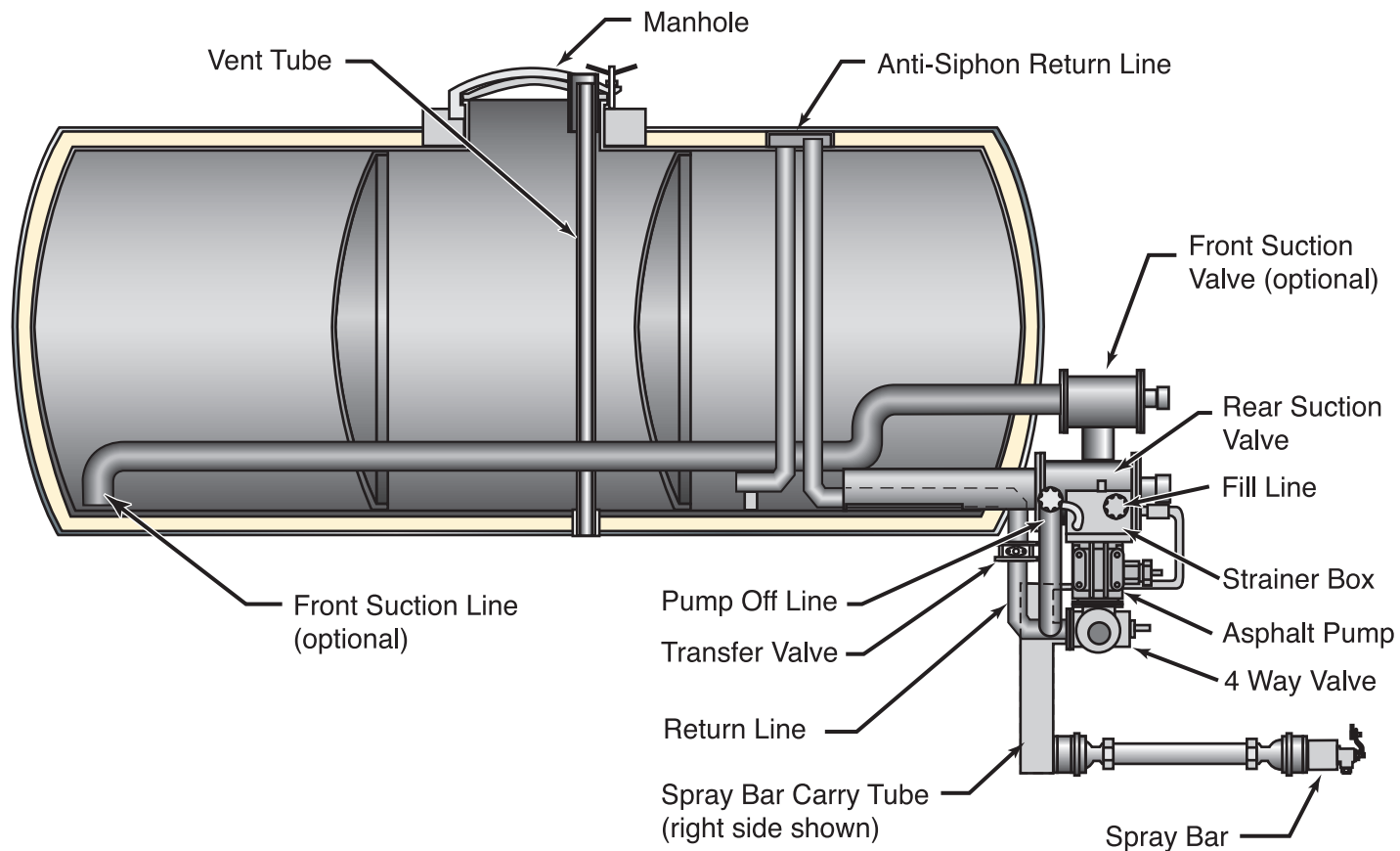

## Tank Suction Valve

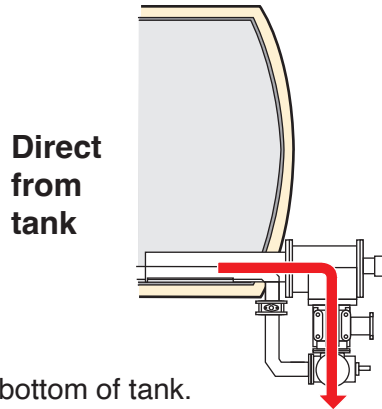

- Located at bottom of tank.
- Air control open, spring close.
- No sump to trap liquid asphalt in the tank.
- Disc valve closes at tank flange. Always in contact with hot asphalt.
- No external line between valve and tank to freeze up with cold asphalt.

## Strainer

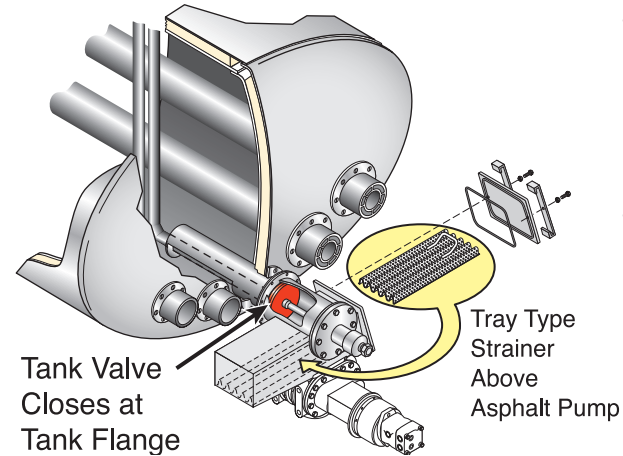

- Strainers, one tray type between tank and asphalt pump and between fill line and asphalt pump.
- All liquid asphalt goes through a strainer before it gets to the asphalt pump.

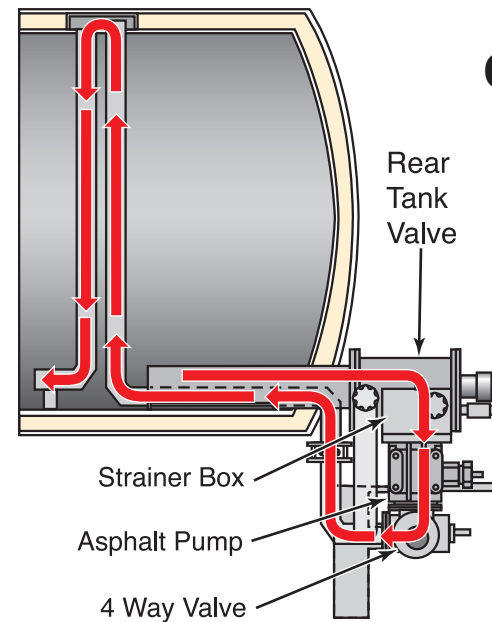
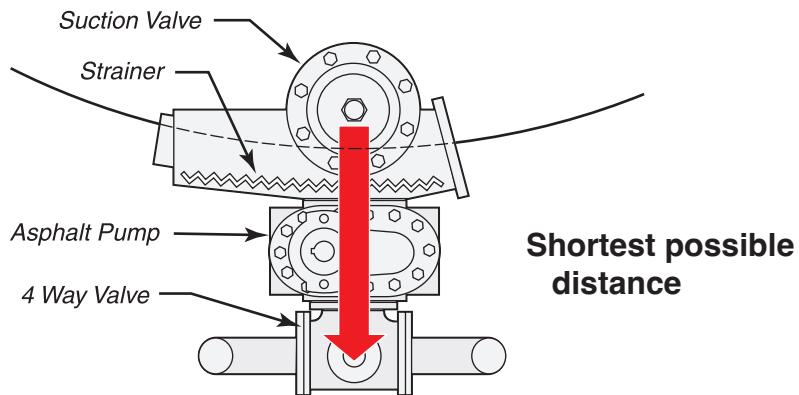

## Circulating In Tank



Circulating System continued

## Asphalt Pump

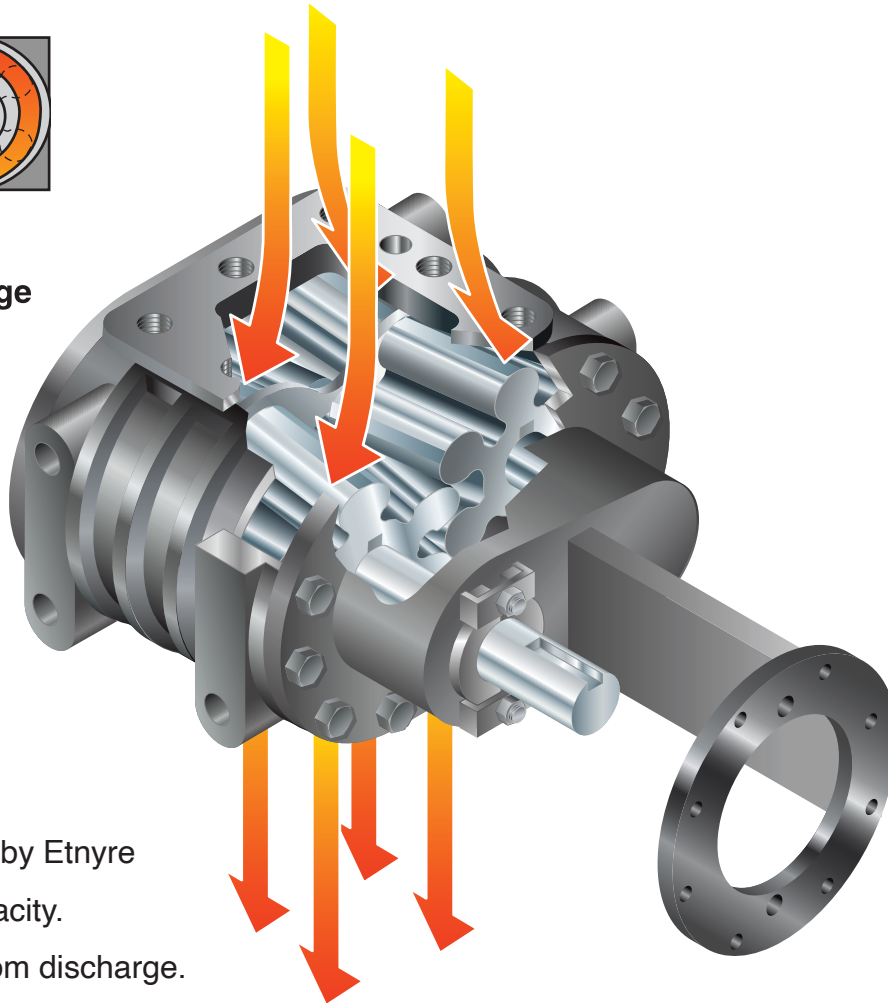
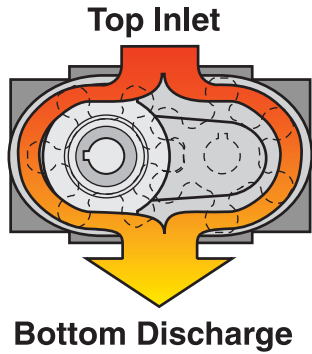

- Manufactured by Etnyre
- 400 GPM capacity.
- Top inlet, bottom discharge.
- No relief valve required.
- Etnyre manufactured especially for asphalt distributors.
- Easy wash out. No low spots to trap asphalt.
- Located below the bottom of the tank.

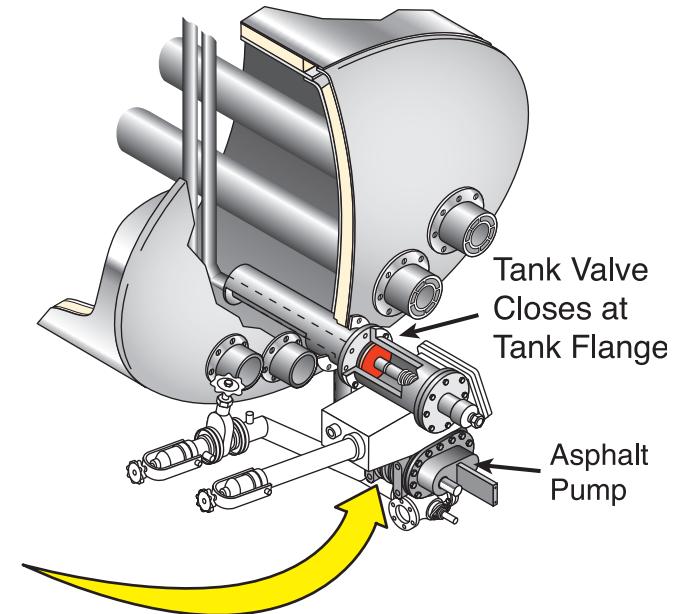
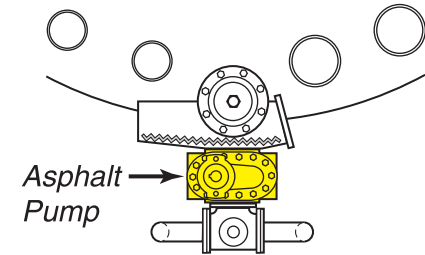

- Tank valve closes at tank flange, asphalt pump bolts directly to valve body.
- Faster heat up, no lines to hold cold asphalt.
- Located for easy maintenance.

## Asphalt Control Valve

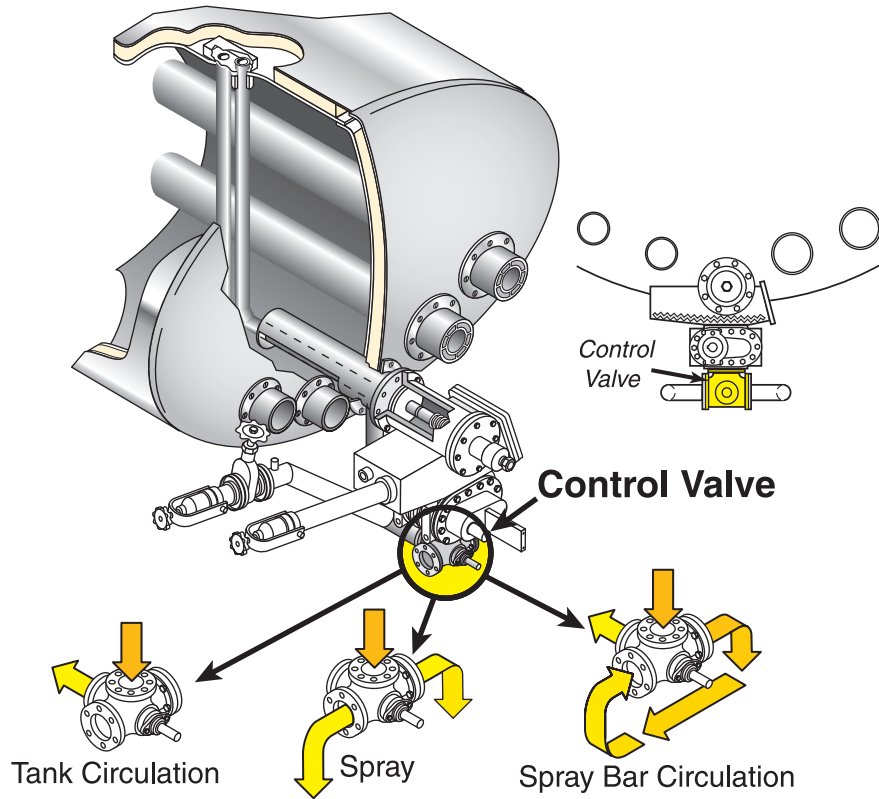

- Single 4-way asphalt valve, less piping and less maintenance.
- Single valve, cast plug type.
- Bolts directly to bottom of asphalt pump.
- No relief valve required.
- Faster heat up, more productivity.

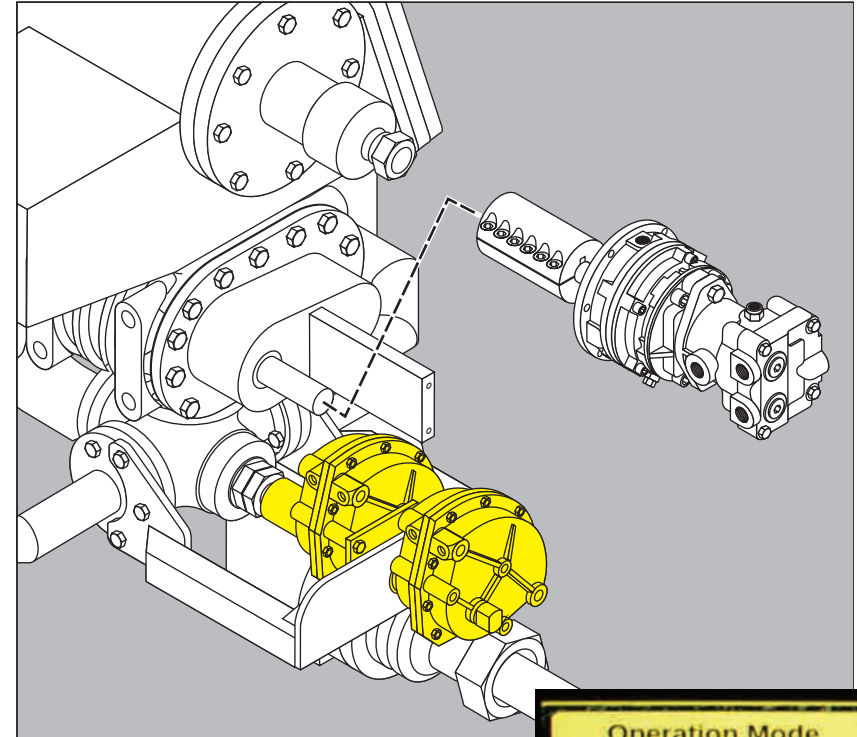

### 4 Way Control Valve Auto Control

- Control for 4 Way Asphalt System
- Allows for total control of 4-way valve.



## Circulating Lines

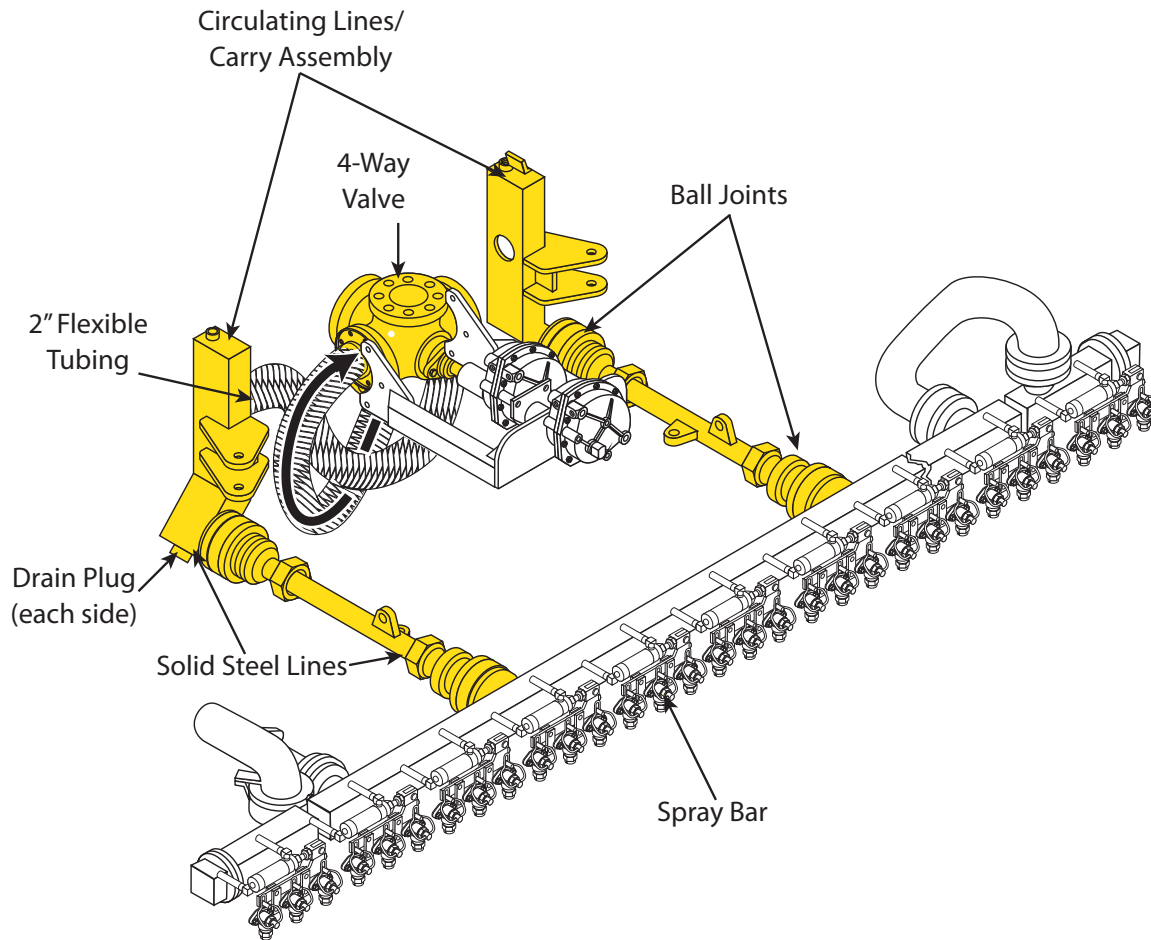

- Circulating system will automatically go from circulate in the spray bar to spray mode and return to circulate in the spray bar without pushing asphalt liquid over a relief valve.
- Solid steel pipe.
- No flexible rubber or steel lines.
- O-ring sealed ball joints, allows 36" spray bar shift and complete vertical travel.
- Minimum number of joints, clean, uncomplicated design.
- Light weight system as circulating lines also carry spray bar assembly, more payload.

Circulating System continued

### Power Washdown (optional)

- Ideal for spraying (fog coat of fuel oil) on spray bar, valves, cylinders, etc. so unit stays clean.

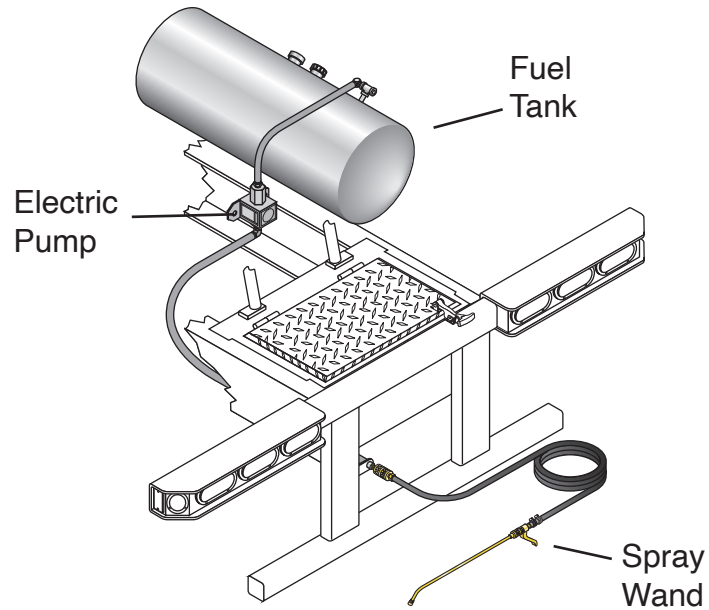

### Front Suction (optional)

- Cab controlled, allows complete tank drainage.
- Provides versatility, draw product from front or rear of tank.
- Useful in hilly areas.
- Aids in faster heating in larger tanks.

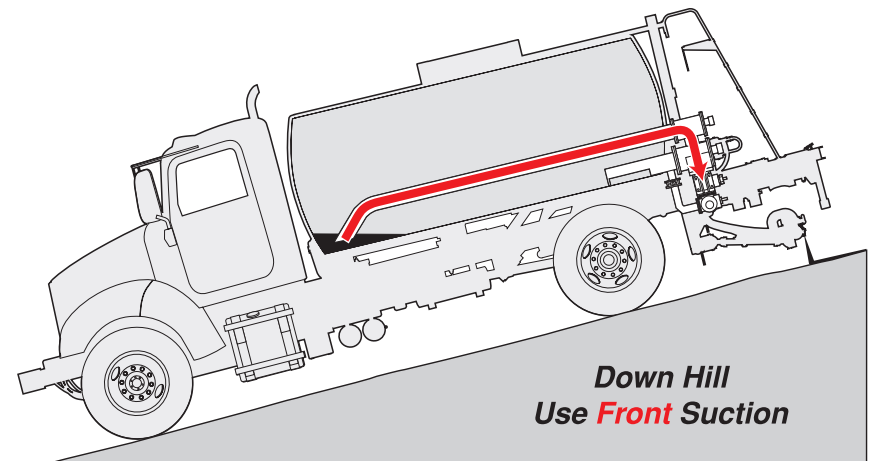

### Mid Tank Draw Off (optional)

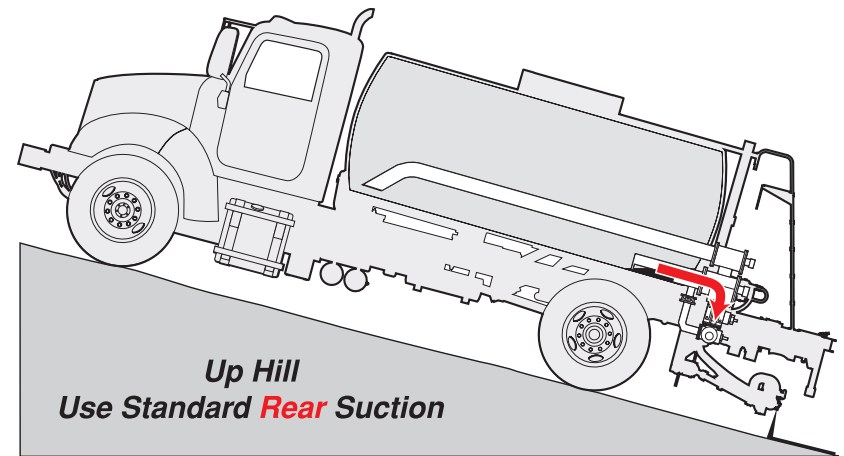
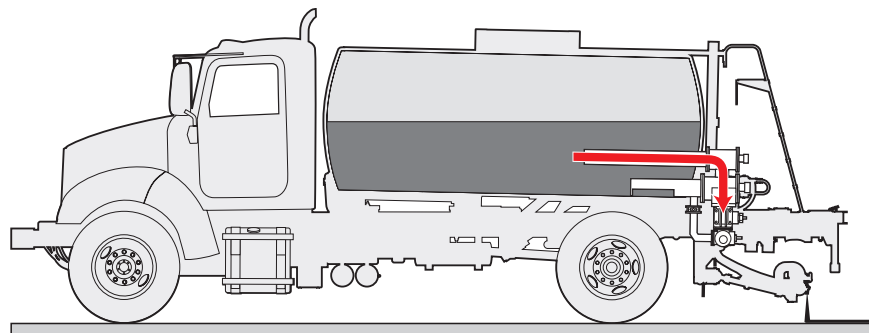

# Spray Bar

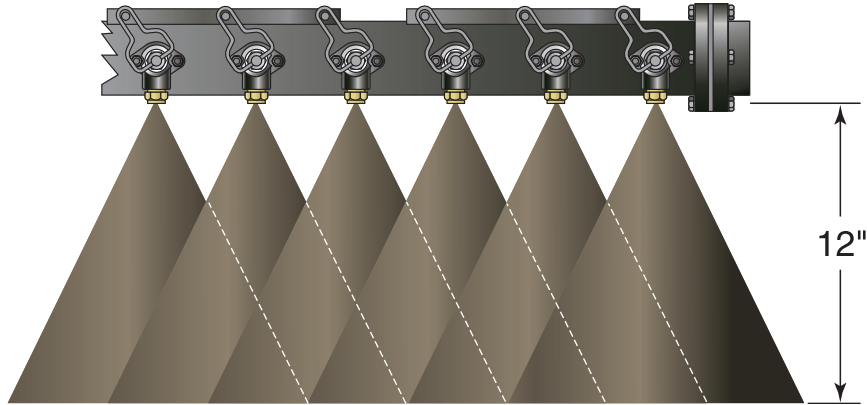

## Triple-Lap Coverage

With nozzles on 4" centers, material sprayed from each nozzle overlaps two other sprays.

- The spray Bar must meet different customer needs such as varying spray widths (1' to 24'), varying applications (0.05 to 1.5 gallon/yd<sup>2</sup>) and optional controls.
- The spray bar must be designed to operate in a tough environment.

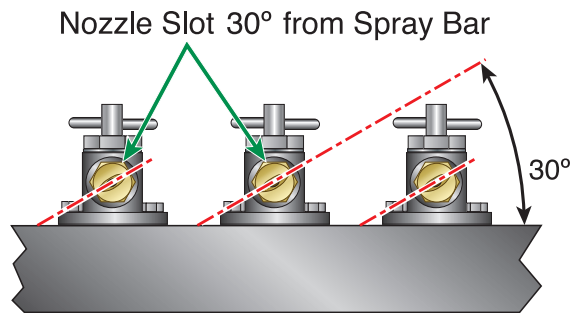
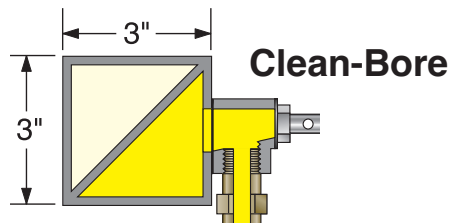

Spray Bar (viewed from bottom of bar)

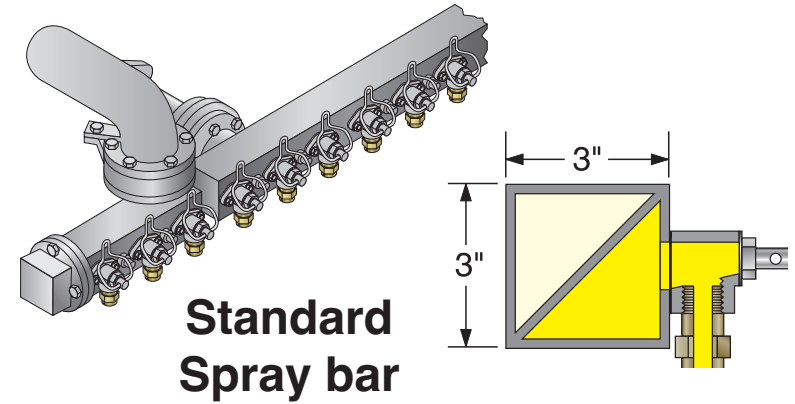
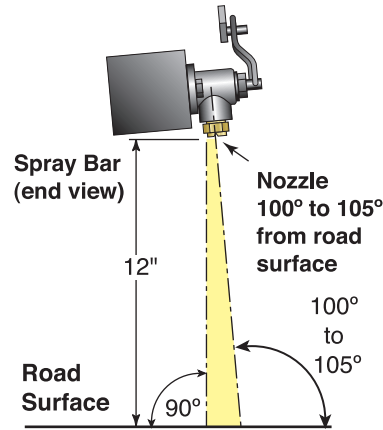

Standard Spray bar

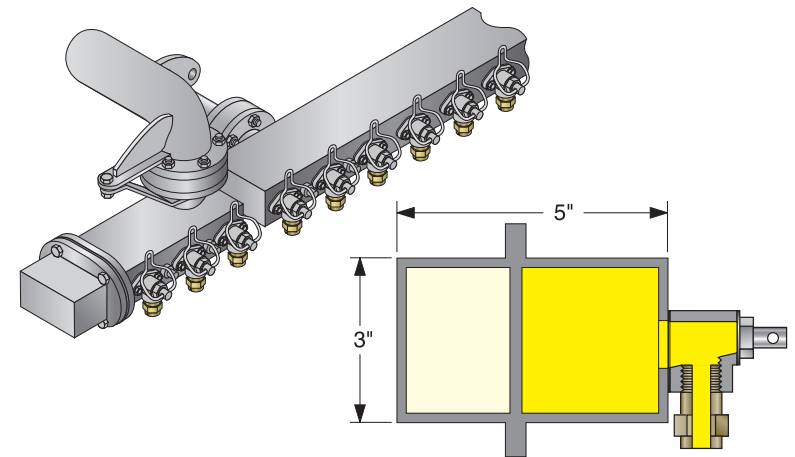

Optional "Big" bar

Advantageous for hot, viscous materials.

## Spray Bar continued

# Spray Bar - 1' Controls (standard feature)

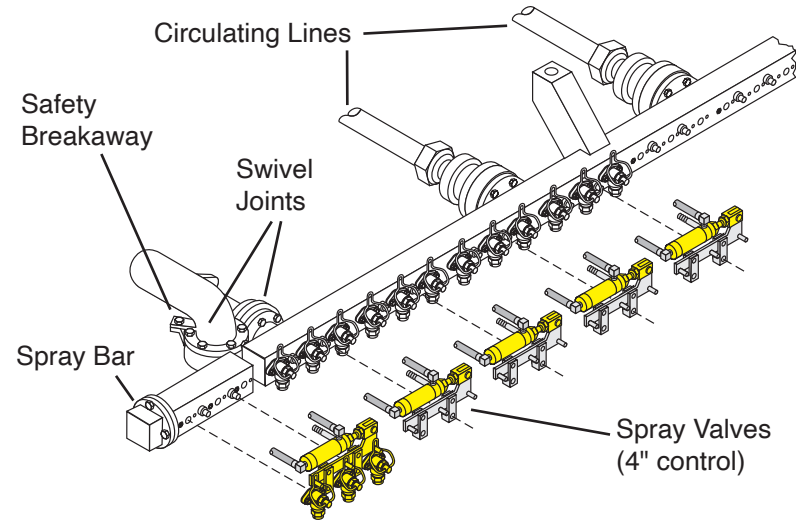

- 1' on/off air controls cab controlled.
- Control spray width in 1' increments from the cab.
- Allows tapered shots controlled from the cab.
- Electric-air solenoids located on the truck frame.
- Air hoses neatly routed to on/off cylinders.
- Easy maintenance and trouble shooting.
- All swivel joints are o-ring seal type (no packing gland to leak or adjust).
- The 3" square tubing gives us 9 square inches cross section for circulating hot liquid asphalt through the spray bar.
- The o-ring swivel joints are designed for years of leak free operation.
- The 8' overall folded width of the spray bar allows for normal travel on the roadway.

## Air Oiler and Water Separator

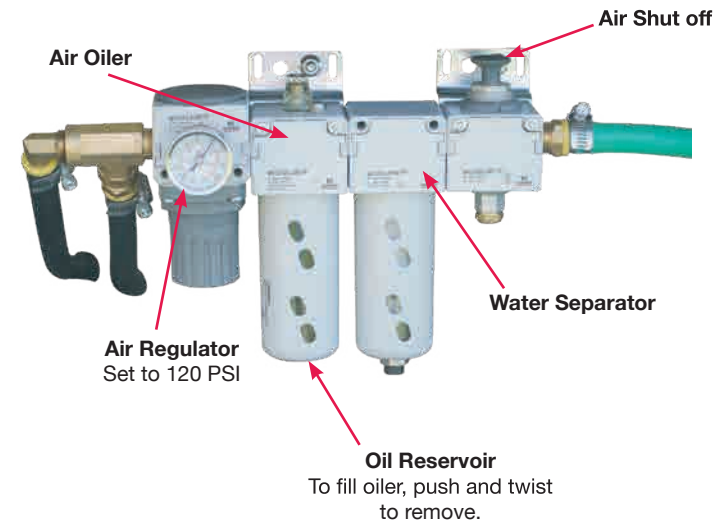

## Spray Bar Power Lift, Shift and Fold (standard feature)

- System has separate hydraulic pump for lift, shift and folding spray bar. While spraying, the application rate of asphalt will not be affected if bar is shifted.
- Total 32" spray bar side shift.
- Switch controls in cab and at rear.
- Full control of spray bar movements.
- Operator Friendly.

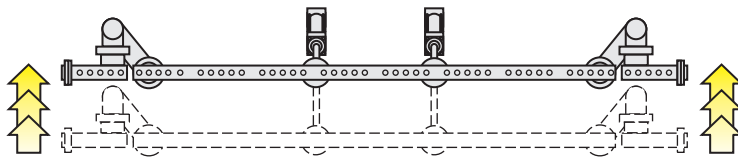

• Lift spray bar hydraulically

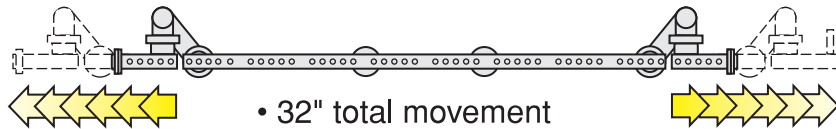

• 32" total movement

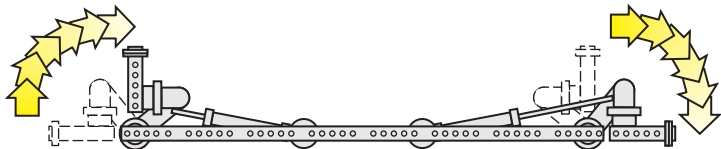

• Hydraulic system will fold 8' wing sections, total 24' spray bar

## Safety Breakaway Standard Feature

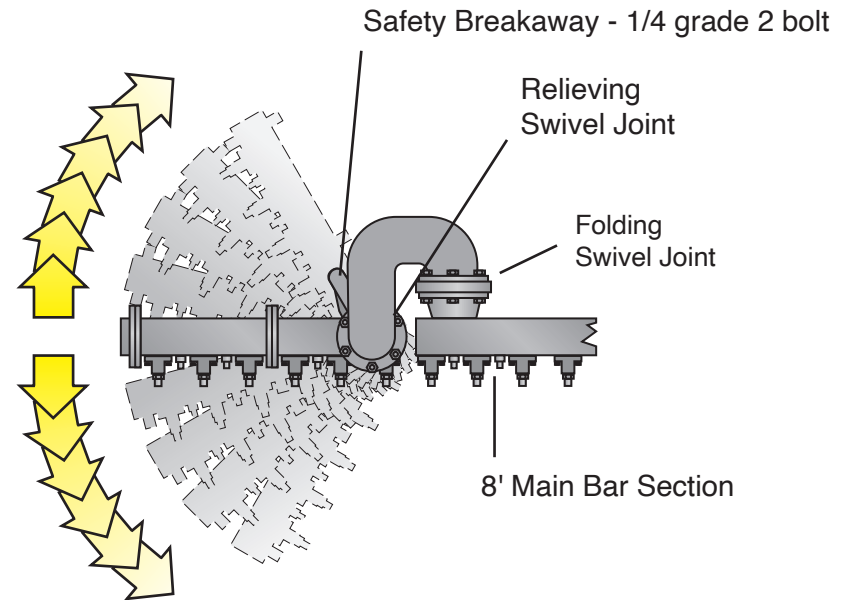

- Relieves both fore and aft, up to 90° angle.
- Protects spray bar from damage.

## Additional Folding Joints (Optional)

- Increased distributor's versatility
- Fold bar extensions not in use up and out of the way. Reduce danger of damage to bar.
- No need to remove bar extensions.
- Operator-Friendly.

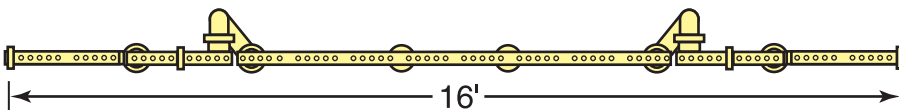
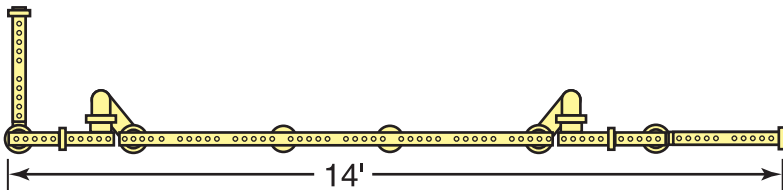
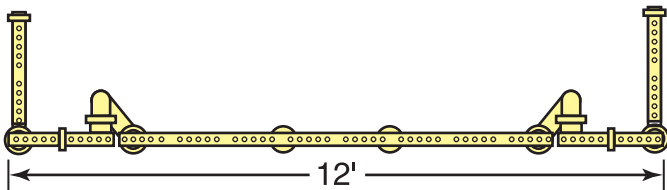
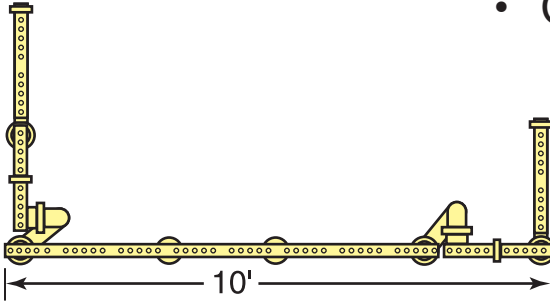
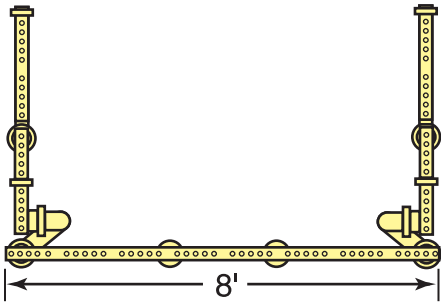

Example: 16' Bar with one extra set of folding joints

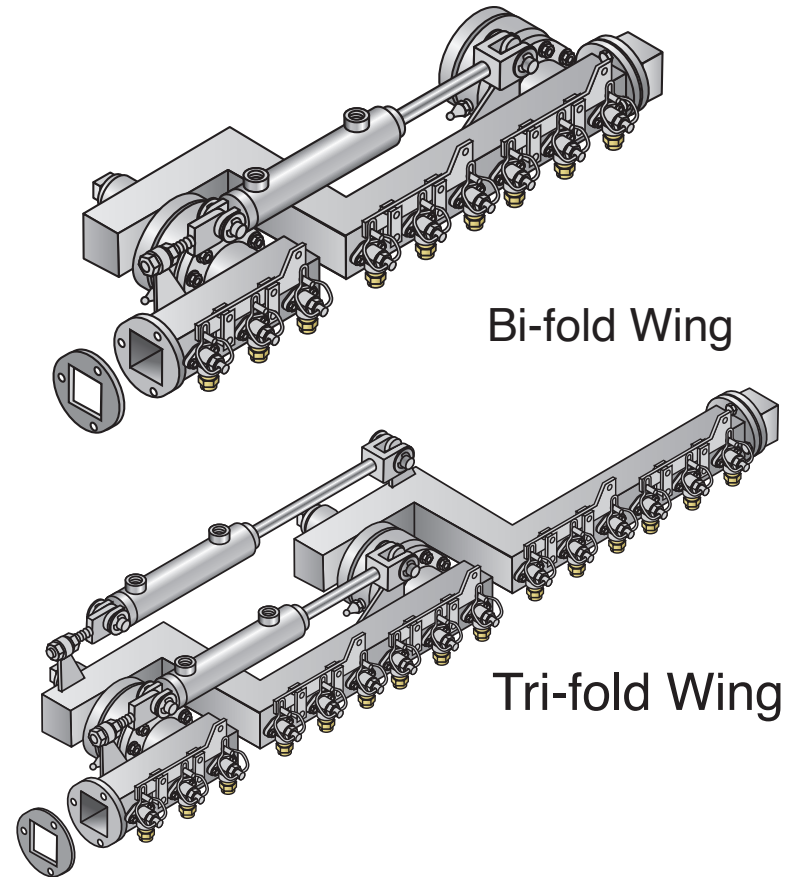



## Spray Bar continued

# Spray Bar Valves

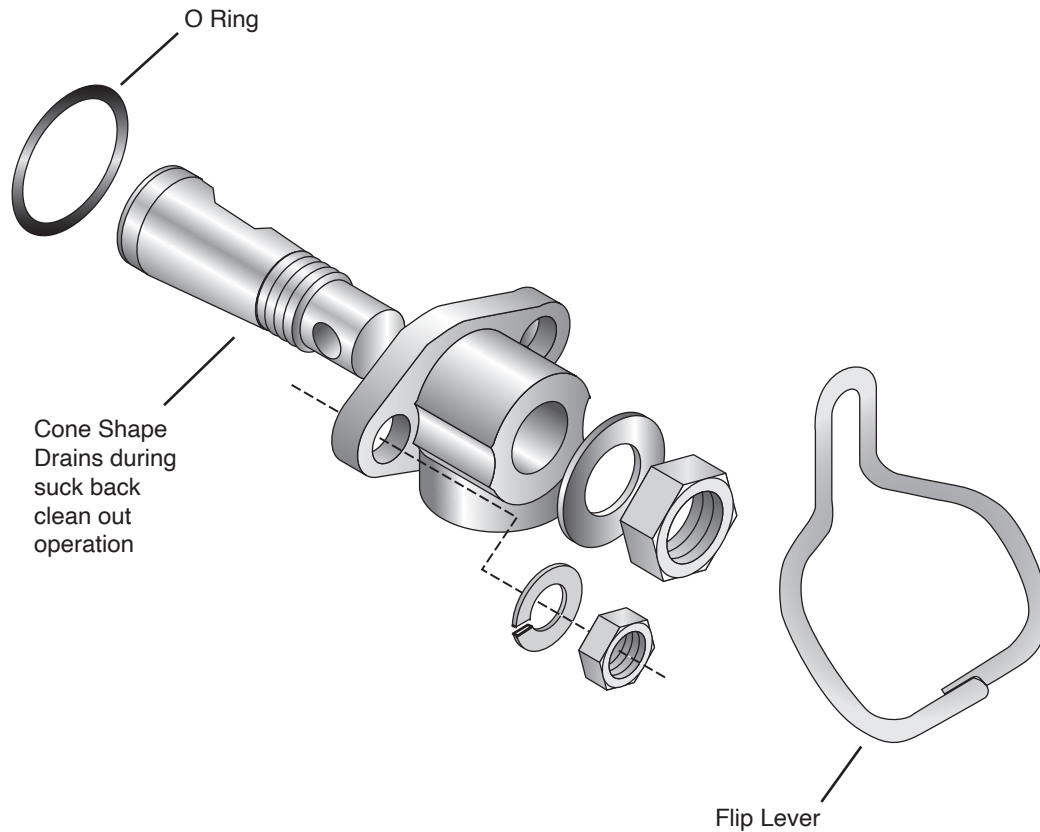

- Easy on/off flip levers for manual control of individual spray valves are standard equipment.
- Hollow plug facilitates fast valve warm up from the inside.
- The external side mounted valves allow for fast circulation and no internal obstructions during spraying. Evens distribution across the width of the bar.

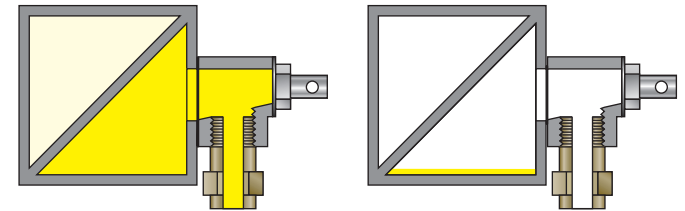

- The side mounted valves have no wear points within the spray bar section. Small amount of old, cold asphalt left in bottom of spray bar is no problem because the discharge is at middle, side.
- The Etnyre valve is rugged and serviceable.

## Circulate and Spray Systems

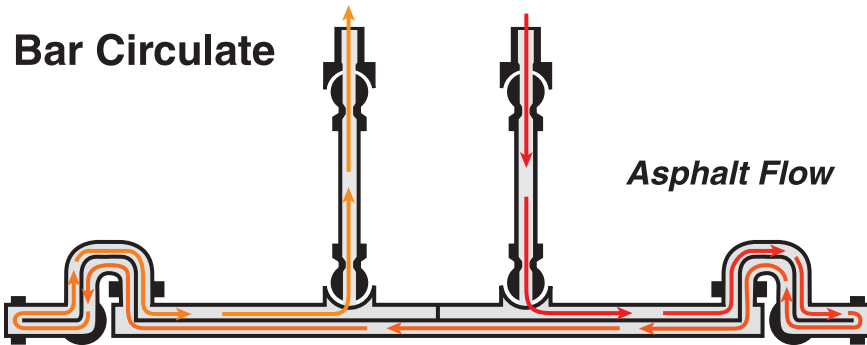

- One spraybar and feed system, easy, fast heat up.
- All Etnyre distributors have positive circulation in full bar and wings when not spraying. Hot asphalt is always circulating.

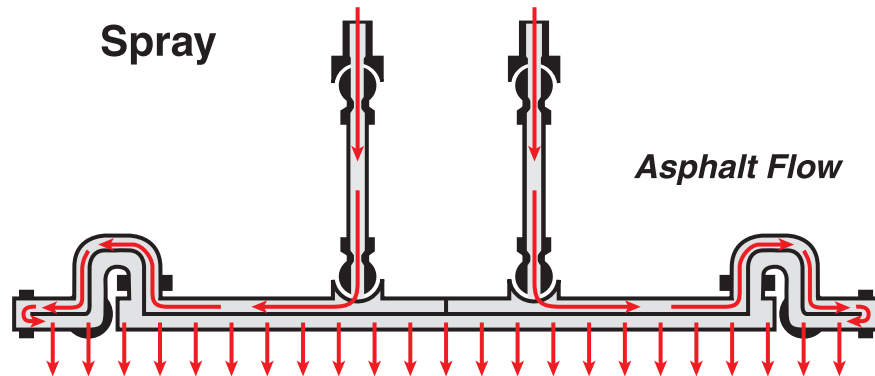

- Balanced, dual feed asphalt flow while spraying.
- Uniform application across full bar and wing width up to 24'.

## Standard Mac Valves

- 3/16" plastic hose.

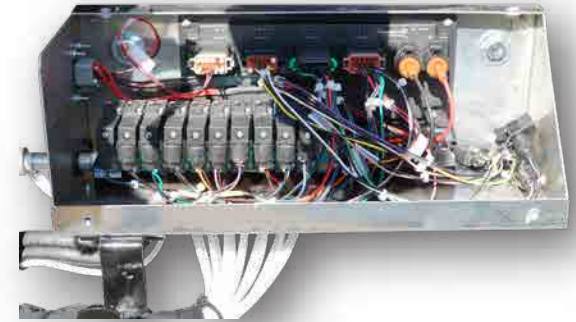

## Manifold Style Mac Valves and Heavy Duty Air Lines (Optional)

- Braided hose with JIC fittings.

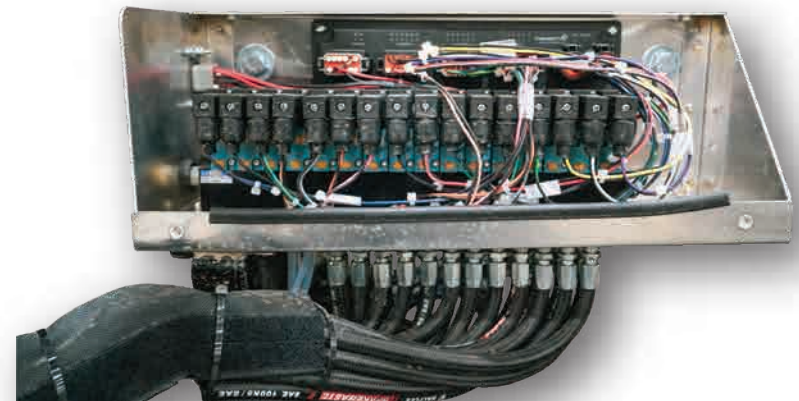

## Spray Bar continued

### Spray Bar Latch-Travel

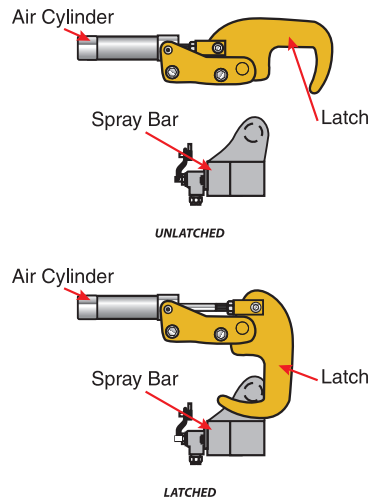

### Wet Storage Box (Optional)

- Carry hose connections.
- Carry tools, etc.

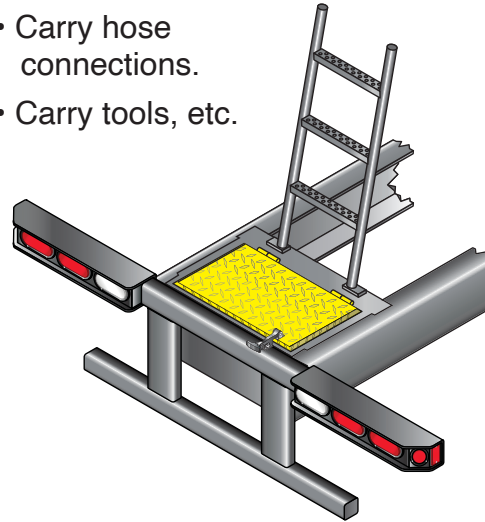

### Bar End Markers (Optional)

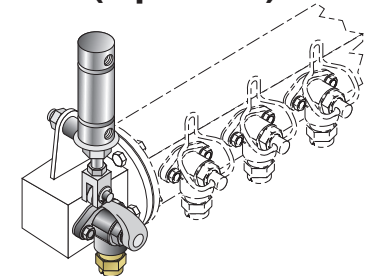

- Single valve at each end of bar.
- For outlining shot before spraying.
- Handy if you need to spray wider.

## Variable Width Spray Bar

- Up to 24' wide shots. Available in 18' or 24' configurations.
- Solid pipe to bar. No flexible asphalt hoses.
- Infinitely variable bar widths.
- 4" width controls.
- Full cab controls.
- Side shift capabilities.



## Variable Width Spray Bar continued

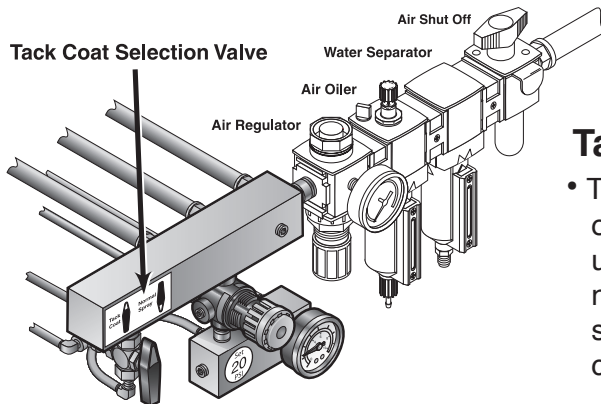
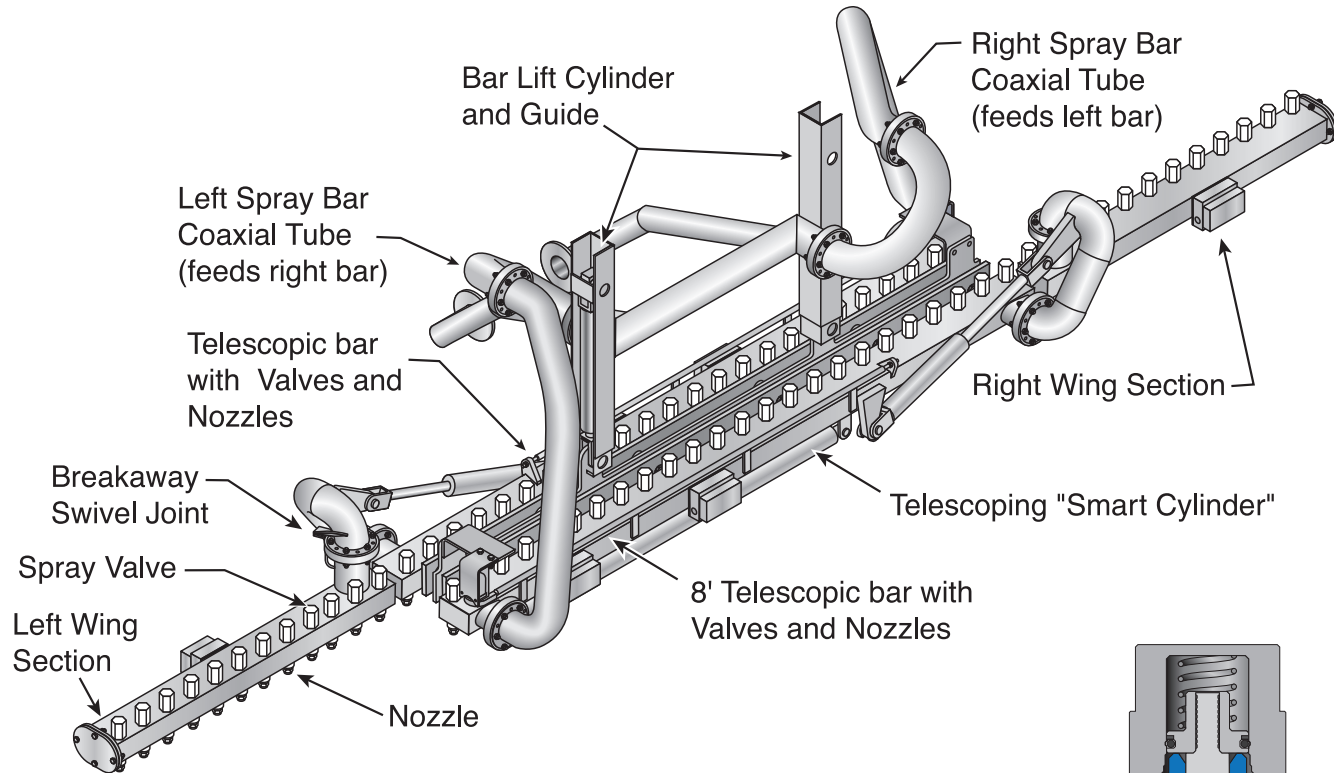

### Tack Coat Valve

- The operator can easily with one valve control switch the unit to shoot every other nozzle to assist in light tack shots without having to change nozzles.

### Spray Valve

- The poppet style spray valve is internal to the spray bar. Very robust valve with no external moving parts.

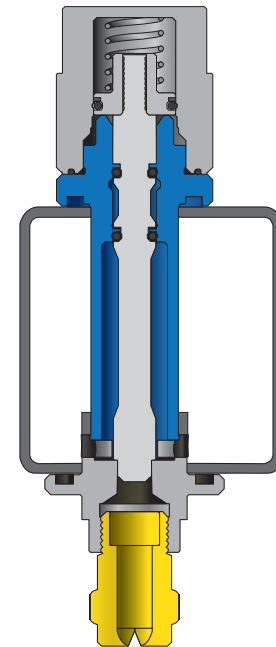

Spray Bar continued

## Etnyre Spray Bar Nozzles

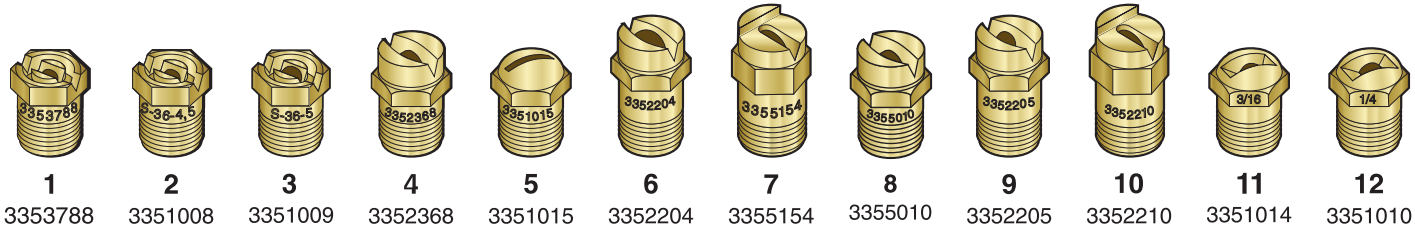

Ref.	Part No.	Description	Application Gallons Per Square Yard	Application (Metric) Liters Per Square Meter	US Flow Gallons Per Minute Per Foot
1	3353788	V Slot Tack Nozzle 1/8" Rifle Bored	.05 – .20	.23 – 0.91	3.0 – 4.5
	3351013*	V Slot Tack Nozzle 1/16" Coin Slot	.05 – .20	.23 – 0.91	3.0 – 4.5
	3354904	V Slot Tack Nozzle 1/8" Counterbored	.05 – .20	.23 – 0.91	3.0 – 4.5
2	3351008	S36-4 V Slot	.10 – .35	.45 – 1.58	4.0 to 7.5
3	3351009	S36-5 V Slot	.18 – .45	.81 – 2.04	7.0 to 10.0
4	3352368	Multi-Material V Slot	.15 – .40	.68 – 1.81	6.0 to 9.0
5	3351015	3/32" Coin Slot	.15 – .40	.68 – 1.81	6.0 to 9.0
6	3352204	Multi-Material V Slot	.35 – .95	1.58 – 4.30	12.0 to 21.0
7	3355154	<i>End Nozzle</i> (use with 3352204 nozzle)	.35 – .95	1.58 – 4.30	12.0 to 21.0
8	3355010	Multi-Material V Slot	.29 – .72	1.31 – 3.26	10.0 – 16.5
9	3352205	Multi-Material V Slot	.20 – .55	.91 – 2.49	7.5 to 12.0
10	3352210	<i>End Nozzle</i> (use with 3352205 nozzle)	.20 – .55	.91 – 2.49	7.5 to 12.0
11	3351014	3/16" Coin Slot	.35 – .95	1.58 – 4.30	12.0 to 21.0
12	3351010	1/4" Coin Slot	.40 – 1.10	1.81 – 4.98	15.0 to 24.0

\* Special Order

# Suck Back System

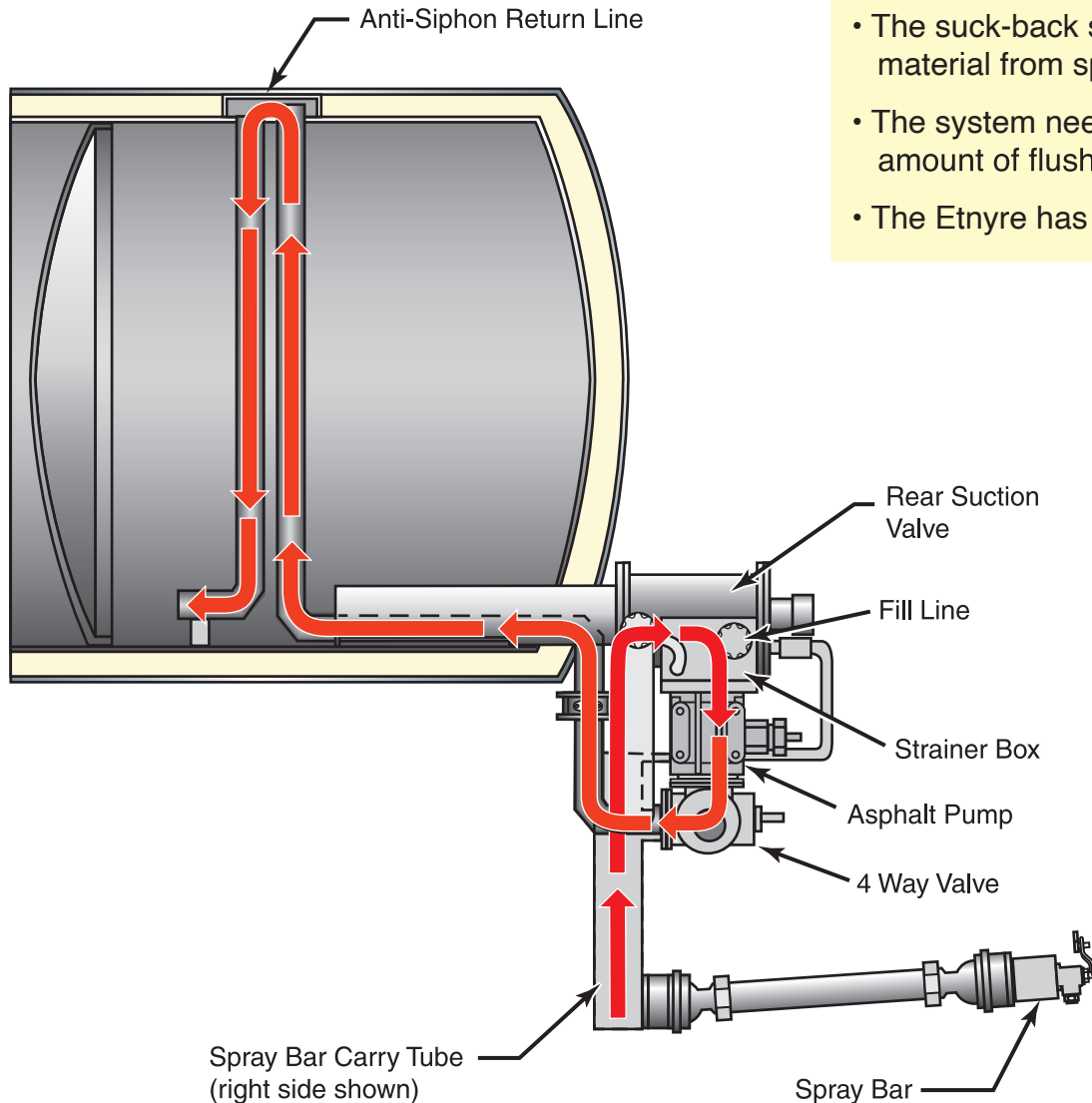

- The suck-back system must return all bituminous material from spray bar to tank.
- The system needs to be designed to use a minimal amount of flushing oil.
- The Etnyre has an exclusive “Vac-u-Flow” system.

- Used to return asphalt from spray bar to tank.
- The Etnyre exclusive system will suck back liquid asphalt without reversing the asphalt pump.
- Requires only 2 to 3 quarts of fuel oil to flush system.
- The asphalt pump sucks return asphalt through the internal suck back line and returns it to the tank.
- Cleaning is complete because 1" diameter Vacu-Flo tubes provide four times the velocity of conventional 3" return lines. Permits less drainback.

## Hand Spray System

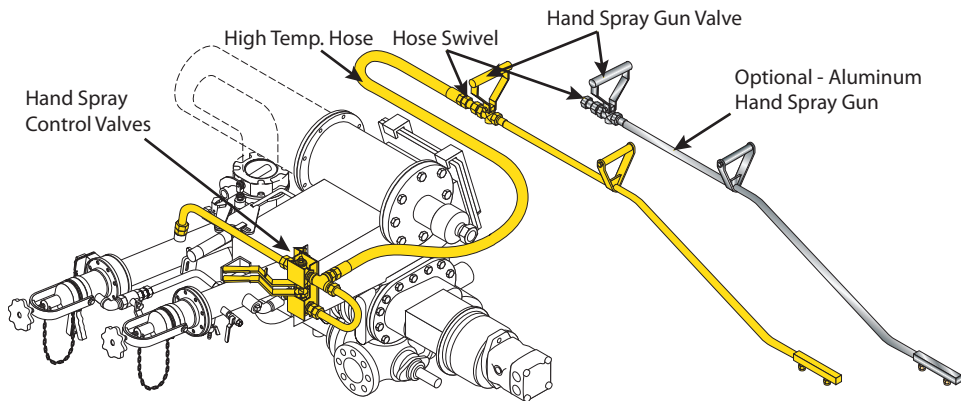

- Hand Spray system consists of:
  - A control valves for hand spray and hand spray suck back.
  - A special high temperature tar and asphalt hose.
  - A spray gun with “cold” handles.
- The handspray system is used for spraying areas where the distributor truck cannot reach, crack filling and other maintenance projects.
- Optional lightweight aluminum hand spray gun.

## Self Flushing System

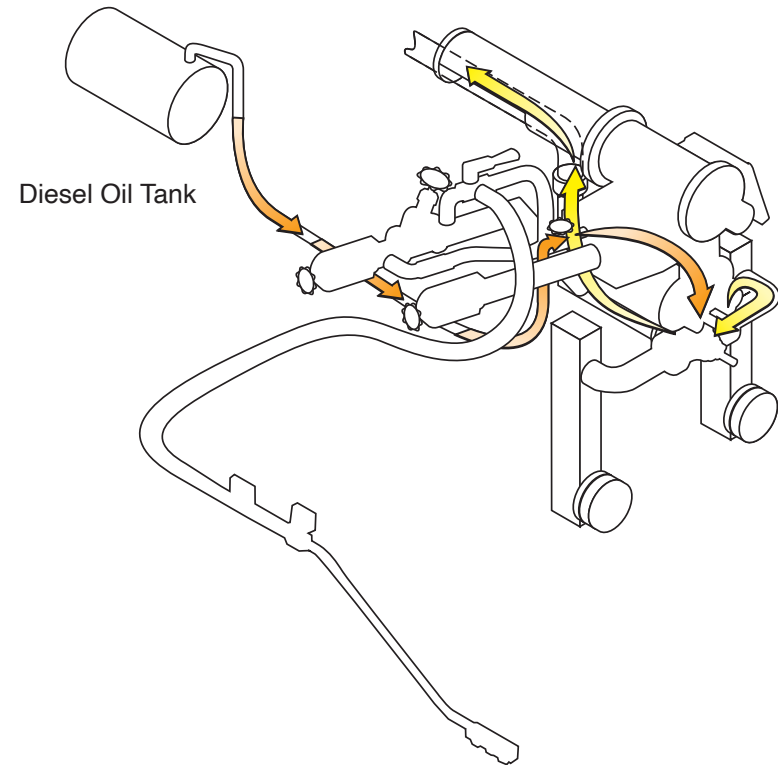

- Used to wash out the circulating system for easy start-up.
- Easy to use.
- Requires only 2-3 quarts to wash out asphalt pump.
- All internal self contained system.
- Environmentally sensitive. Because we suck back virtually all of the material from our spray bar and lines, we need only to wash the asphalt pump clean.

# Power System

- Power system takes power from chassis to turn asphalt pump through the hydrostatic pump and motor.
- The operator must have ample power to handle all grades of asphalt.

## P.T.O. drive

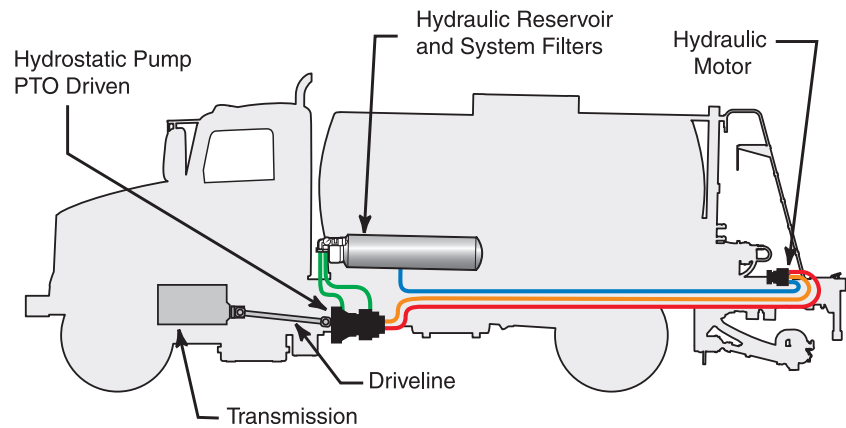

- Hydraulic pump coupled through P.T.O. to truck transmission.
- No front extension on chassis.

## Front Crankshaft Drive system

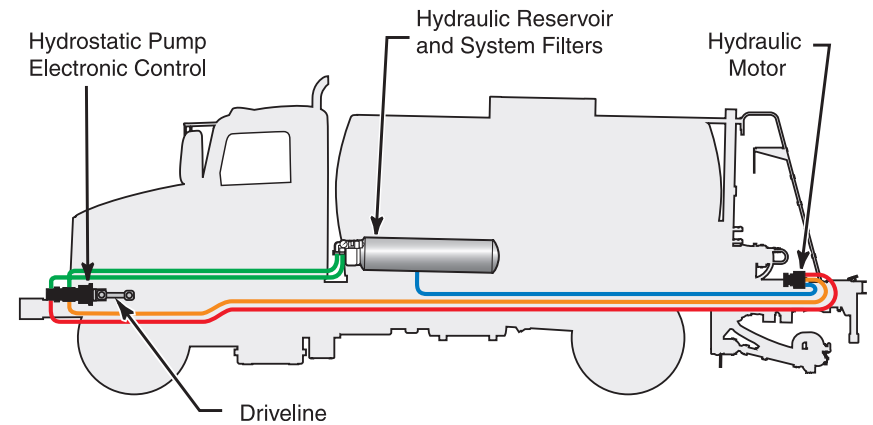

- Hydraulic pump coupled directly to truck engine
- 100% control of hydrostatic system with truck engine running.
- No P.T.O. maintenance.
- No clutch interference to system power.
- Requires access to engine crankshaft.



**Optional  
Hydraulic Oil Cooler**



## Hydraulic Pumps

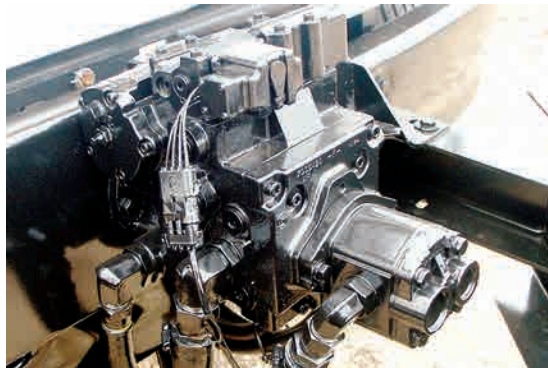

**RexRoth  
2.7 CID**  
with 1.7 CIU motor



**Optional  
4.57 CID  
(90 Series)**  
with 2.1 CIU motor  
& 4.39 Gearbox



**Optional  
6.1 CID  
(90 Series)**  
with 2.69 CIU motor  
& 4.39 Gearbox

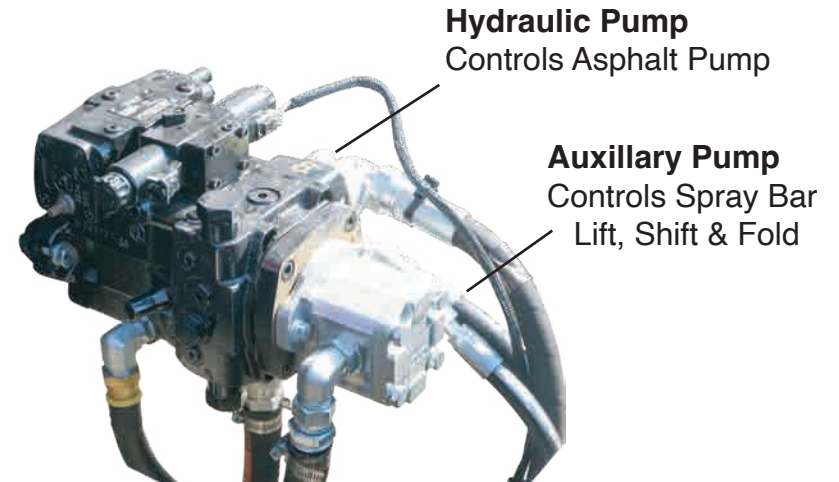

## Hydrostatic Drive System for Asphalt Pump

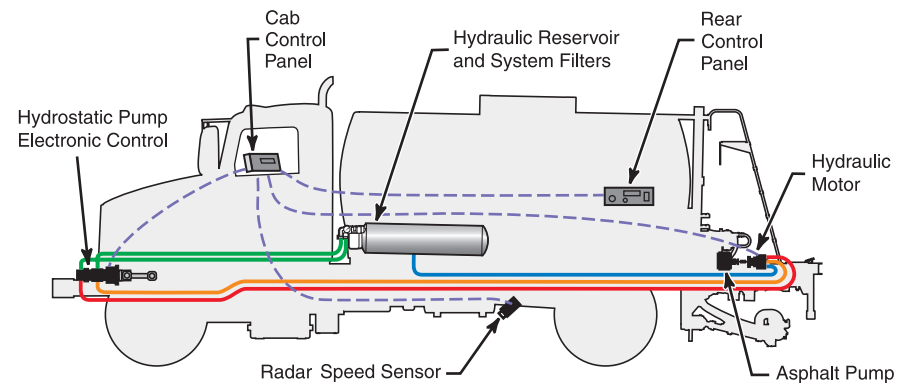

- Hydrostatic drive, infinitely variable control.
- Allows for variable truck speed and on the run changes in bar width.

Power System continued

## Hydraulic Motor

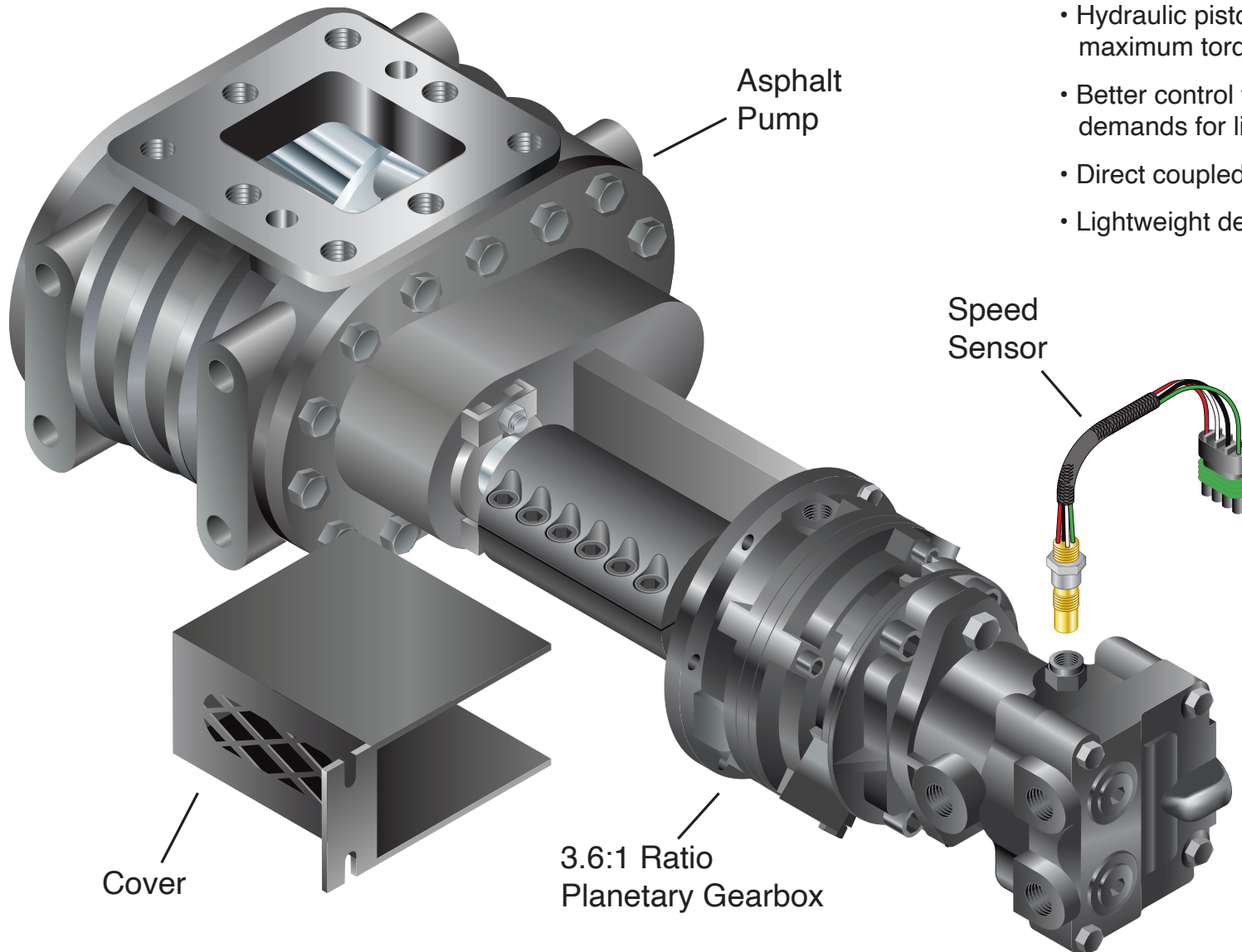

- Hydraulic piston motor and gear box deliver maximum torque to asphalt pump.
- Better control from low to the high output demands for liquid asphalt.
- Direct coupled to asphalt pump.
- Lightweight design for more payload.

# Metering and Control System

The distributor is designed to apply a controlled and metered amount of bituminous material. The unit of measurement is in gallons per square yard. Distributors are used to apply applications from 0.05 g/yd<sup>2</sup> up to 1.5 g/yd<sup>2</sup>. The metering system has advanced with technology.

- The metering system gives the operator precise control of the application of asphalt.
- The metering system has either manual or computer control.

Four important features need to be considered

- 1) Desired Application Rate - Gallon/Yard<sup>2</sup>
- 2) Forward Ground Speed - Feet Per Minute
- 3) Asphalt Pump Output - Gallons Per Minute
- 4) Width of Spray - Feet

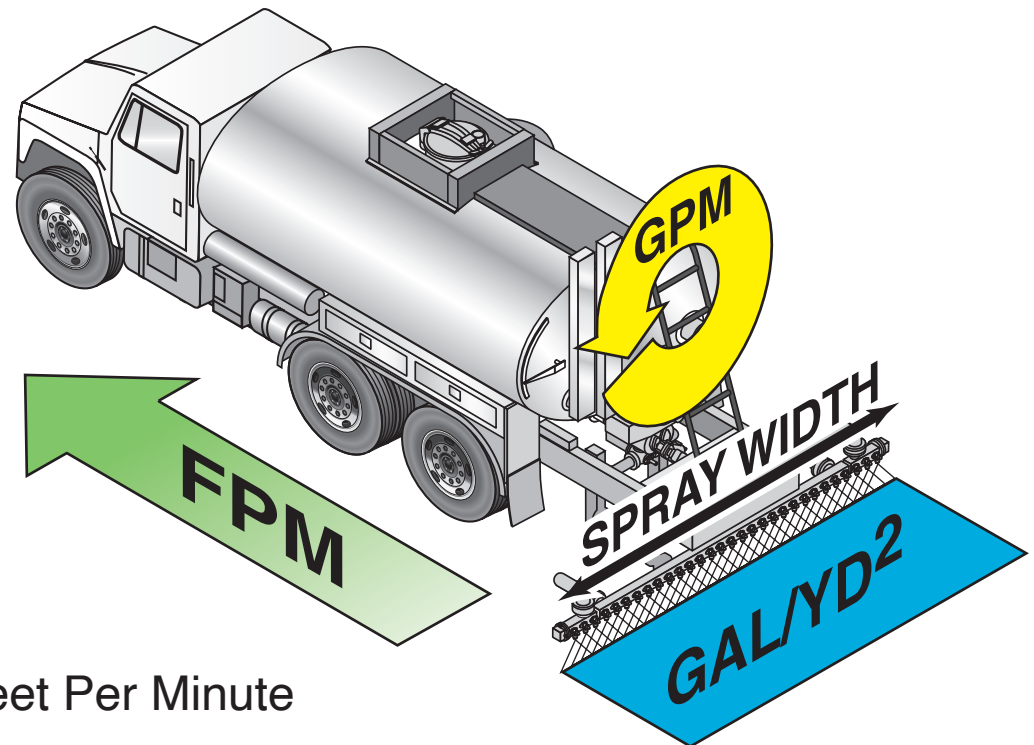

## Magnetic Pump Speed Sensing

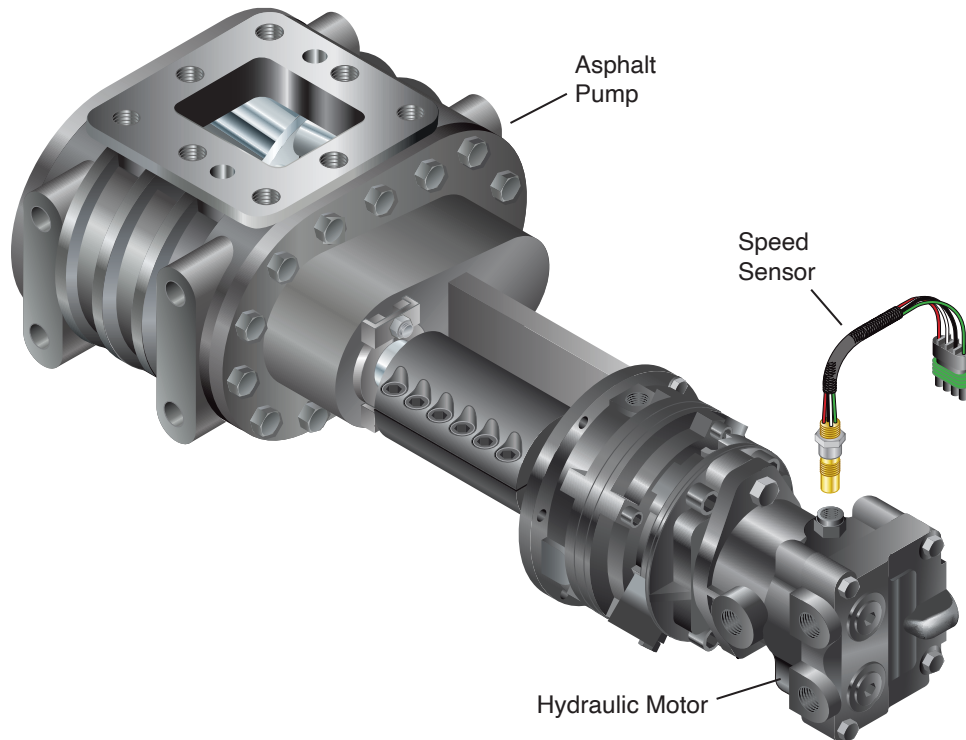

- Speed sensor pick-up counts the revolutions of the asphalt pump.
- Speed sensor is internal to the hydraulic motor.
- Pump output is measured with Gallons Per Minute (GPM).

## Radar Ground Speed Sensing



- Radar Speed sensing is **standard equipment**.
- Precise measurement of ground speed and distance.
- No moving parts to wear out, less maintenance, and less chance of damage.
- Ground speed is measured in Feet Per Minute (FPM).

## Computer Control

- **The Etnyre computer eliminates the need to match pump output to distributor speed.** Enter the desired application rate and the computer automatically maintains that rate regardless of distributor speed, bar width or transmission gear changes during operation. No more calculations or dry runs. Increased accuracy and flexibility.
- **Ten different application rates can be stored in memory and recalled with the push of a button.** The pumping rate can be adjusted for loading and circulating without changing the stored rates. A built-in self diagnostic program monitors the control circuits. Preset circulation rates are programed for all functions. Computer calculates circulate in bar rate to give you even starts and stops.
- **Change application rate while spraying** and return to any other rate as required, on the run.
- **No switching between displays for information.** The computer screen displays application rate, gallons per minute and feet per minute on one screen, at the same time.
- **For maximum performance,** combining one foot spray bar controls with the computer application rate computer provides variable width capabilities with the flick of a switch from the cab.



- **Control panel with 1' incremental spray controls.** Change speed and/or adjust spray width using control panel switches and the computer control will automatically maintain the preset application rate.



The Etnyre **Smart Clean** system is a closed system which pulls flushing solvent from the Flush Tank, pumps it through the circulating system and spray bar and returns the solvent to the Flush Tank

- **Computer Controlled.**
- **Adjustable Function Times.**
- **Automated Valves.**

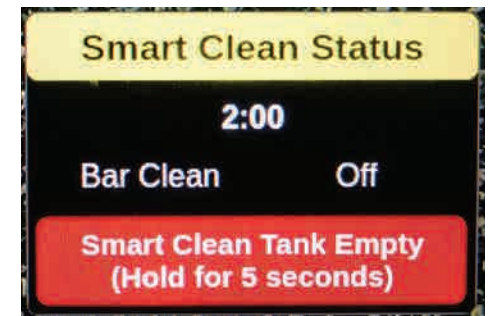
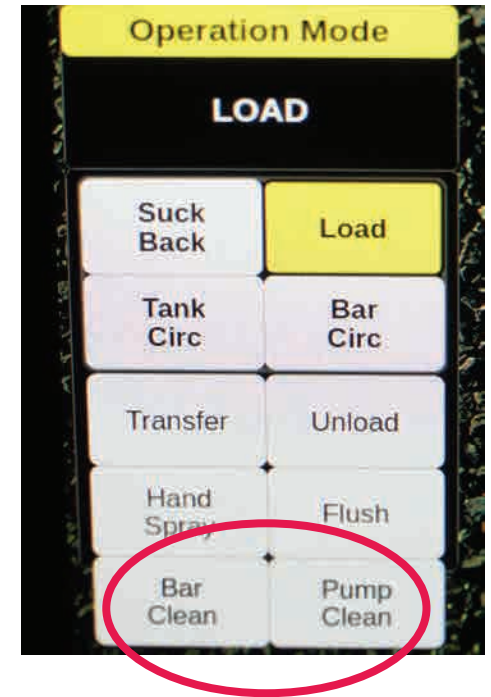
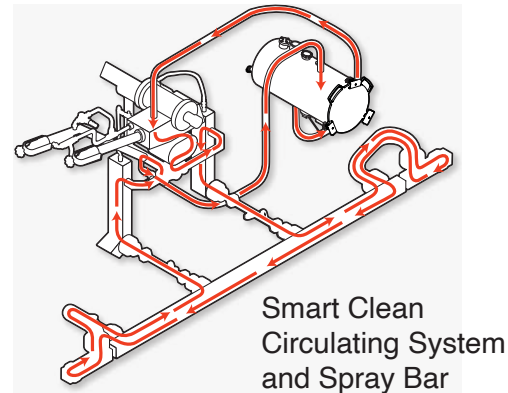
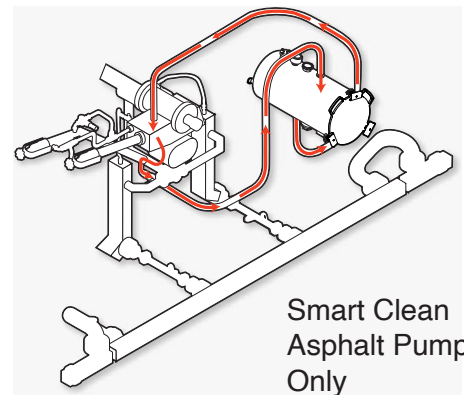
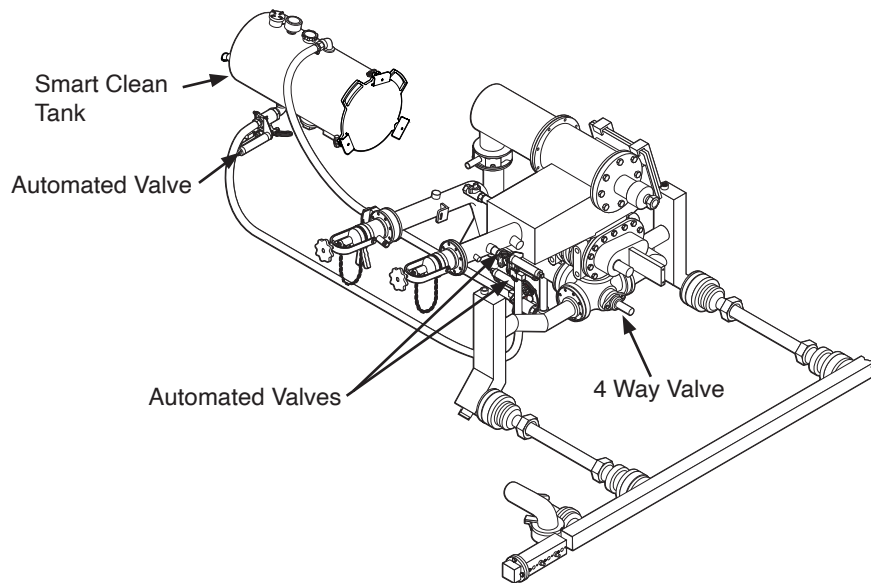

# Enviro-Green<sup>®</sup> Asphalt Distributor





- Eliminates Diesel and LPG Burners, Utilizes 12Kw Electric Process Heat
- Onboard Hydraulic-driven Generator for in-the-field heating
- Stationary Heat - Plug unit into shop outlet to maintain product temperature, 240V Single Phase 50 Amp Heating
- Minimal product needed in tank for operation of heaters
- The Etnyre SmartClean system is a closed system which pulls flushing solvent from the Flush Tank, pumps it through the circulating system and spray bar, and returns the solvent to the Flush Tank



# Chassis

## Important Chassis Information

- The chassis is a very important and integral part of a bituminous distributor.
- The gross vehicle weight rating must be adequate to support the loaded distributor.
- The transmission and rear axle ratios are extremely important. Not all transmissions work.
- For more information, visit [www.etyre.com](http://www.etyre.com) and follow the directions: Scroll down to "OUR PRODUCTS", click "ASPHALT DISTRIBUTORS", and click "The Truck Thing" (see next page for more details)

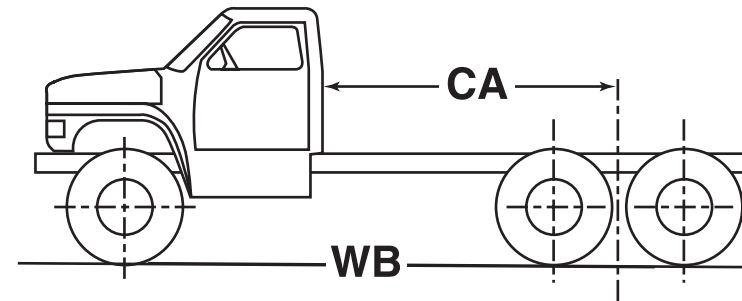
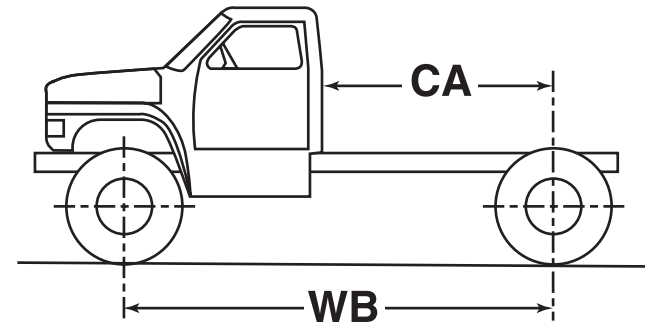

- **Front Crankshaft\*** \_\_\_\_\_
- **Useable Cab to Axle** \_\_\_\_\_
- **Wheel Base** \_\_\_\_\_
- **GVWR** \_\_\_\_\_
- **GAWR Front** \_\_\_\_\_
- **GAWR Rear** \_\_\_\_\_
- **Transmission** \_\_\_\_\_
- **Rear Axle Ratio** \_\_\_\_\_

\* Requires access through or under radiator and an adapter plate on crank. \_\_\_\_\_

# General Truck Requirements by Tank Size

Conventional			Size		
Nominal Gallonage	Tank Oval Size	Useable c.a./c.b.	Front G.A.W.R.	Rear G.A.W.R.	Total G.V.W.R.
1000*	47x78x104	79" - 84"	8,100	17,500	25,600
1250*	47x78x122	97" - 102"	9,000	17,500	26,500
	47x78x128	108"			
1500	53x88x122	102"	9,000	19,000	28,000
	50x83x138	112" - 117"			
	47x78x146	120"			
	47x78x152	126"			
1750	59x89x122	102"	10,000	21,000	31,000
	53x88x137	108"			
	53x88x140	120"			
	50x83x144	126"			
2000*	53x88x146	119" - 124"	12,000	21,000	33,000
	59x89x140	120"	12,000	21,000	33,000
2250	59x89x158	102" - 108" (tandem/SAX)	14,600	23,000	37,600
2250 - 2500	CONSULT FACTORY				
3000*	65x90x186	130.5" - 135.5" (@ 54" axle spread)	16,000	34,000	50,000
3500*	70x82x192	136.5" - 141.5" (@ 54" axle spread)	16,000	40,000	56,000
4000*	70x92x204	147.25" - 152.25" (@ 54" axle spread)	18,000	44,000	62,000

For more information, visit [www.etnyre.com](http://www.etnyre.com) and: Scroll down to "OUR PRODUCTS", click "ASPHALT DISTRIBUTORS", and click "The Truck Thing"

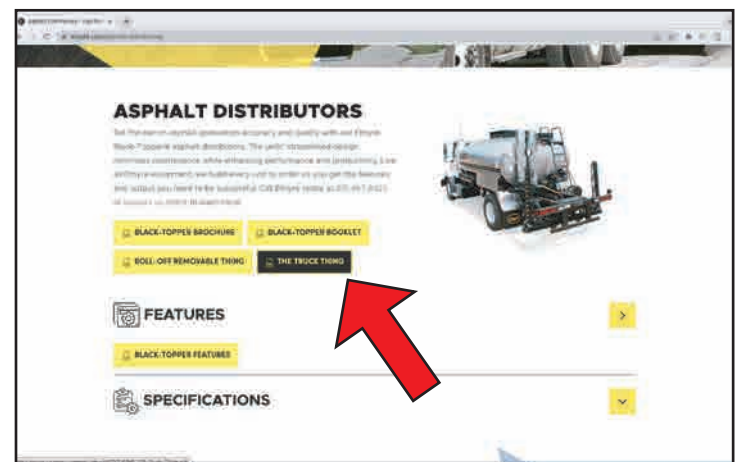
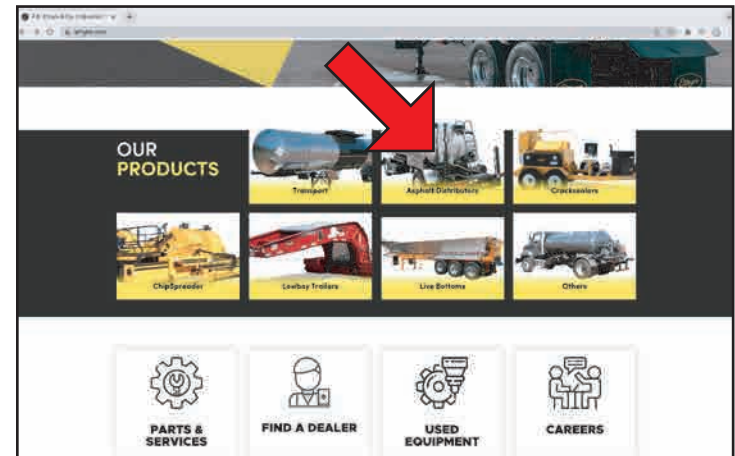







## **E. D. Etnyre & Co.**

1333 South Daysville Rd., Oregon, IL 61061  
**Phone 815-732-2116 or 800/995-2116**

**Fax 815/732-7400**

email: [sales@etnyre.com](mailto:sales@etnyre.com)

[www.etnyre.com](http://www.etnyre.com)