



Scan this QR Code
for online parts
manual MP-SR-22



Scan this QR Code for
online version of this
manual



Hydraulic Ramp Trailers-Model SR



Operation



Maintenance



Safety



E.D. ETNYRE & CO. 1333 S. Daysville Road, Oregon, Illinois 61061

Phone: 815/732-2116 or 800/995-2116 • Fax: 800-521-1107 • www.etnyre.com

PARTS / SERVICE: 888-586-1899

Safety Precautions, Hazard Seriousness Level

You will find safety information boxes throughout this manual. These boxes contain information alerting you to situations or actions to avoid.

Signal words (DANGER, WARNING and CAUTION) are used to identify levels of hazard seriousness. Their selection is based on the likely consequence of human interaction with a hazard. Definitions of hazard levels are as follows.



DANGER - Immediate hazards which will result in severe personal injury or death.



WARNING - Hazards or unsafe practices which could result in severe personal injury or death.



CAUTION - Hazards or unsafe practices which could result in minor personal injury or product or property damage.

Reporting Safety Defects

If you believe that your vehicle has a defect which could cause a crash or could cause injury or death, you should immediately inform the National Highway Traffic Safety Administration (NHTSA) in addition to notifying E. D. ETNYRE & CO.

If NHTSA receives similar complaints, it may open an investigation, and if it finds that a safety defect exists in a group of vehicles, it may order a recall and remedy campaign. However, NHTSA cannot become involved in individual problems between you, your dealer or E. D. ETNYRE & CO.

To contact NHTSA, you may either call the Auto Safety Hotline toll-free at 1-800-424-9393 (or 366-0123 in Washington, D. C. area) or write to: NHTSA, U. S. Department of Transportation, Washington, D. C. 20696. You can also obtain other information about motor vehicle safety from the hotline.

General

This manual contains operation, maintenance and service instructions for the Etnyre SR Series trailers (see figure 1). The operating instructions must be read and understood before operating the unit. The operator must be responsible for maintaining the unit in good working condition.

To identify the maximum load capacity of your trailer, examine the Etnyre model number. It contains a condensed description of the unit.

This manual covers the standard features and options of the Etnyre Paver Special series trailers. If your trailer incorporates custom features, some of the information contained in this manual may not apply. If you have any questions regarding this manual or your trailer, contact your dealer or the E. D. Etnyre Service Department at 1-800-995-2116.

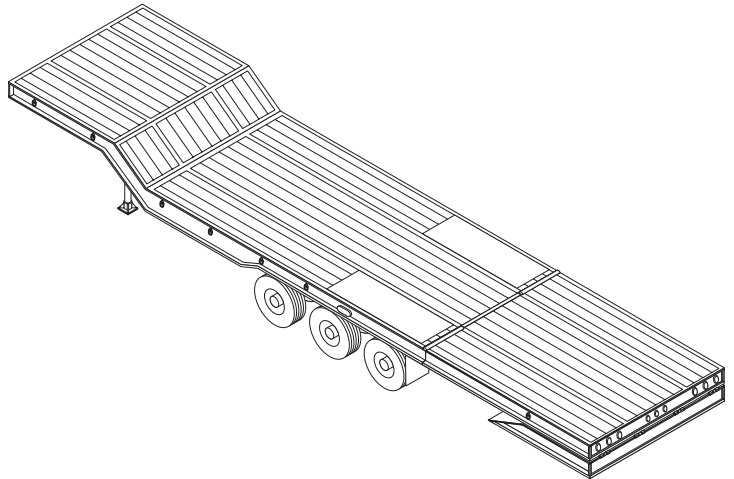

Figure 1. Etnyre SR Trailer

Unit Nameplate or Certification Label

The unit serial number plate or certification label is located on the left hand gooseneck beam web. The nameplate or certification label must remain permanently affixed to the unit. (See figure 2).

Serial Number Data

The unit serial number on the certification label is also stamped into the gooseneck beam web plate near the nameplate and on the outside frame member at the left hand forward corner of the frame. (See figure 2).

NOTE: The complete serial number must be identified when ordering parts or communicating service information to Etnyre.

Trailer Capacity Data

Trailers manufactured in the United States list the maximum "Gross Vehicle Weight Rating" (GVWR) and the maximum "Gross Axle Weight Rating" (GAWR) on the certification label.

The Gross Vehicle Weight Rating is the sum of the trailer weight and the trailer capacity. This is the maximum structural capacity of the trailer.

The Gross Axle Weight Rating is the maximum load any axle can carry.

The certification label shows "GVWR" and "GAWR" at reduced speeds, at the bottom of the label. The GVWR may be reached under certain circumstances before the GAWR or vice versa.

 WARNING
Do not exceed the GVWR or GAWR at the specified speed. These weight limitations are independent of road weight limitations imposed by law.

Tire and Rim Data

The certification label lists the correct rim size, tire size and tire inflation pressures for the trailer.

 WARNING
Do not use undersize rims or tires. Do not underinflate or overinflate the tires.

System Specifications

Unit specifications are listed in the General Section



		MFD. BY ETNYRE TRAILER CO. OREGON, IL U.S.A.	Q508064
SERIAL NUMBER:	<input type="text"/>	MFD. DATE	<input type="text"/>
GVWR:	<input type="text"/> KG	<input type="text"/> (LBS)	
GAWR:	<input type="text"/> KG	<input type="text"/> (LBS)	ALL AXLES
WITH	<input type="text"/> TIRES	<input type="text"/>	RIMS, DUALS
INFLATION PRESSURE	<input type="text"/> KPa	<input type="text"/> (PSI)	COLD
THIS VEHICLE CONFORMS TO ALL APPLICABLE FEDERAL MOTOR VEHICLE SAFETY STANDARDS IN EFFECT ON THE DATE OF MANUFACTURE SHOWN ABOVE.			
VIN:	<input type="text"/>	WEIGHT:	<input type="text"/> (LBS)
CLASSIFICATION: TRAILER		MODEL: <input type="text"/>	

Figure 2. Unit Nameplate or Certification Label

Operating Instructions

Operating instructions are contained in the Operation Section.

 WARNING
The operator must understand the operating instructions completely before operating the unit. Personal injury and/or damage to the unit may occur if the operating instructions are not followed.

Warning and Caution Information

Warning and caution information is given throughout this manual. Particular care must be given to warning and caution information contained in the Operation Section (Operating Instructions) and where noted with proper service procedures in other sections.

NOTE: Warning and caution decals are affixed to all units at the factory. These decals contain warning and caution information which must be followed by all persons operating or servicing an Etnyre trailer. Any warning or caution decal which is lost, or difficult to read, **must be replaced at once**. Replacement decals may be obtained from any Etnyre trailer dealer.

Refer to Figure 3 for the location of the nameplate and decals on the Etnyre trailer.

Nominal Size	Thread Series	SAE Grade 5 Capscrews				SAE Grade 8 Capscrews			
		Torque (ft. lbs.)		Torque (Nm)		Torque (ft. lbs.)		Torque (Nm)	
		DRY	LUBED	DRY	LUBED	DRY	LUBED	DRY	LUBED
1/4	20 UNC	8	6	11	9	12	9	16	12
	28 UNF	10	7	13	10	14	10	19	14
5/16	18 UNC	17	13	24	18	25	18	33	25
	24 UNF	19	14	26	20	27	20	37	28
3/8	16 UNC	31	23	42	31	44	33	59	44
	24 UNF	35	26	47	36	49	37	67	50
7/16	14 UNC	49	37	67	50	70	52	95	71
	20 UNF	55	41	75	56	78	58	105	79
1/2	13 UNC	75	57	100	77	105	80	145	110
	20 UNF	85	64	115	86	120	90	165	120
9/16	12 UNC	110	82	145	110	155	115	210	155
	18 UNF	120	91	165	125	170	130	230	175
5/8	11 UNC	150	115	205	155	210	160	285	215
	18 UNF	170	130	230	175	240	180	325	245
3/4	10 UNC	265	200	360	270	375	280	510	380
	16 UNF	395	225	405	300	420	315	570	425
7/8	9 UNC	430	320	580	435	605	455	820	615
	14 UNF	475	355	640	480	670	500	905	680
1	8 UNC	645	485	875	655	910	680	1230	925
	14 UNF	720	540	980	735	1020	765	1380	1040
1 - 1/8	7 UNC	795	595	1080	805	1290	965	1750	1310
	12 UNF	890	670	1210	905	1440	1080	1960	1470
1 - 1/4	7 UNC	1120	840	1520	1140	1820	1360	2460	1850
	12 UNF	1240	930	1680	1260	2010	1500	2730	2050
1 - 3/8	6 UNC	1470	1100	1990	1490	2380	1780	3230	2420
	12 UNF	1670	1250	2200	1700	2710	2040	3680	2760
1 - 1/2	6 UNC	1950	1460	2640	1980	3160	2370	4290	3210
	12 UNF	2190	1650	2970	2230	3560	2670	4820	3620

Table 1. Torque Specifications For Standard Hardware

NOTE: This table lists torque values for standard hardware and is intended as a guide for average applications involving typical stresses and machined surfaces. Values are based on the physical limitations of clean, plated and lubricated hardware. In all cases, when an individual torque value is specified, it should take priority over values given in this table. Replace original equipment with hardware of equal grade.

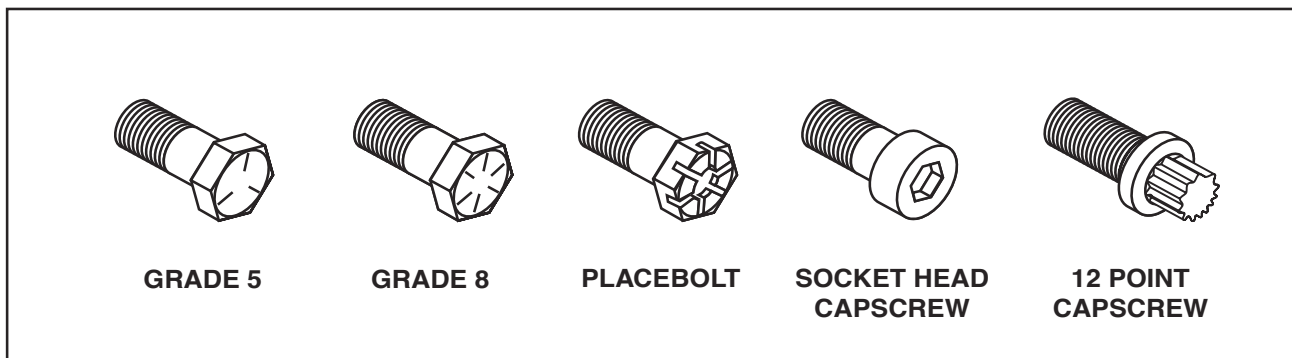

General

This section contains information required for the operation of Etnyre RPS model trailers.

WARNING

Read these instructions thoroughly and observe them when operating Etnyre trailers. Operate by Authorized, Trained Personnel only!

The trailer must be maintained in good operating condition. Minor damage can quickly result in a major failure if not repaired.

WARNING

Do not operate a trailer needing repair.

Do not undersize the prime mover. The prime mover (tractor) must be compatible with the trailer and have adequate capacity.

Do not permit the bottom of a trailer with low ground clearance to hit or slide on or over curbs, railroad crossings or other obstructions that can cause damage to the trailer or stall the vehicle.

Do not exceed either the GVWR or GAWR shown on the certification label. These ratings are listed for trailers at various speeds and reflect the maximum GVWR and GAWR at those speeds.

Keep personnel clear when loading and unloading trailers.

Trailer to Tractor *Connect* Procedure

1. Inspect the fifth wheel area and the trailer frame for wear, structural cracks, damaged or broken decking.
2. Check the kingpin for wear or damage. Replace it if the diameter measures less than 1 7/8" at any point (see figure 5).
3. Check the bolts for tightness. Tighten if required. Refer to Table 1 for correct torque values.
4. Connect the trailer to the fifth wheel.
5. Connect the glad hands and build up reservoir air pressure. Make sure that air line connections between trailer and truck are made.
6. Connect the plug into the electrical socket. Make

sure that electrical connection between trailer and truck is made.

7. Check the lights, turn signals and reflectors for operation.

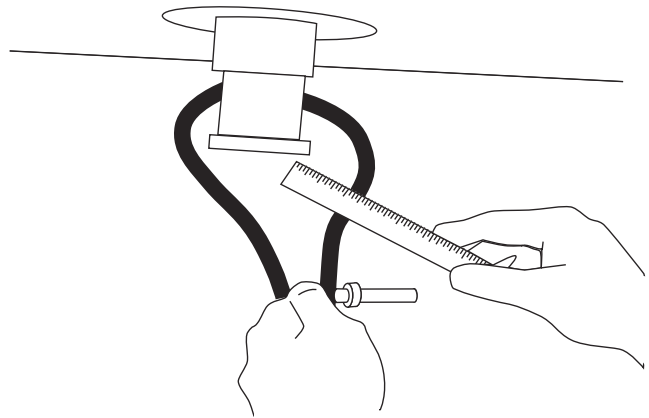

Figure 5. Inspection of Kingpin for wear

WARNING

Check to insure that the kingpin is locked into the tractor fifth wheel.

8. Before operating the trailer, test the air brake system using the following procedure:
 - a. Check the air system pressure. The system must hold 100 PSI (7 Bar) minimum.
 - b. Apply the brakes. Inspect the brake action on all the wheels for proper application.
 - c. Release the brakes. The brakes must release promptly. The air pressure must discharge quickly from the relay emergency valve.
 - d. Disconnect the emergency line from the trailer. The trailer brakes must automatically apply.
 - e. Connect the emergency line to the trailer. The trailer brakes must release.
9. Check the tires for proper inflation pressure. Inspect the tires for cuts or other damage.
10. Raise the landing legs and pin them in the up position.

Trailer to Tractor *Disconnect* Procedure

1. Disconnect the electrical and air connection between the gooseneck and the truck.
2. Lower the landing legs and pin them in the lowered position.

WARNING

Block the trailer wheels

3. Disconnect the fifth wheel lock pin.
4. Pull tractor away from the trailer.

WARNING

Keep hands and feet clear of the point where the frame contacts the ground.

General Rear Loading and Unloading Procedures

These procedures must be followed when rear loading or unloading trailers.

WARNING

Load and unload on solid, level terrain.

All rear loading trailers must be connected to the prime mover (tractor) during all rear loading and unloading procedures.

1. Set the brakes on the prime mover and trailer.

WARNING

Block the trailer wheels.

2. When loading or unloading the trailer from the rear, block under the rear of the trailer frame and under the load ramps.

NOTE: Place blocks under the load ramps to support the ramps during loading or unloading. These trailers can also be loaded and unloaded from a dock or embankment.

WARNING

Use care when loading and unloading. Move the machine on or off the trailer slowly!
Extension bracket will not support the full load weight.

3. Center the load. Do Not load to one side. Position the load for proper weight distribution.
4. Fasten the load to the trailer.

General Road Check Procedures

During road stops, check the trailer and the load using the following procedures:

1. Check the fastening equipment.

WARNING

The load must be securely and adequately fastened to the trailer

2. Inspect the trailer frame structure.
3. Check all the trailer brake drums for heating.

NOTE: A cool brake drum can indicate an inoperative brake.

WARNING

The load must be securely and adequately fastened to the trailer.

WARNING

Proceed cautiously since a malfunctions or misadjusted brake can cause the drum to become extremely hot. **Do Not** operate the trailer until the cause of overheating is corrected.

4. Check to be sure all the wheel nuts are tight. Tighten as required (see Figure 10),
5. Check the tire inflation. Inspect the tires for cuts or other damage.

 **WARNING**

Do Not bleed air from the tires when they are hot.

6. Inspect the lights, turn signals and reflectors for operation.

 **WARNING**

Do not operate a trailer needing repair. Correct any problems found during the road check immediately.

Page left intentionally blank.

SR SERIES TRAILER

OPERATION

GENERAL INFORMATION

LOADING AND UNLOADING PROCEDURES

[SEE FIGURES 1-2 THROUGH 1-10].

WARNING: Model SR trailers **MUST** be **CONNECTED** to the **TRACTOR** during **ALL** loading and unloading procedures. Model SR trailers **MUST** be loaded and unloaded from the **REAR** of the trailer. Load and unload Model SR trailers on solid level terrain **ONLY**.



Use the **FOLLOWING** procedures to **LOAD** and **UNLOAD** ETNYRE Model SR - Hydraulic Ramp Trailers.

a. Set the brakes on the tractor **AND** trailer. Put blocks under the trailer wheels at **BOTH** the front and the rear.

WARNING: Block the wheels securely.



b. Start the power pack engine [IF so equipped] **OR** connect the trailer hydraulic lines and engage the pump on truck operated units.

DANGER: **NEVER** enter under **EITHER** ramp during **LOADING** or **UNLOADING** operations of the trailer.



NEVER enter under **EITHER** ramp **UNLESS BOTH** ramps are **SUPPORTED** by the **MAIN** ramp compression blocks and the **APPROACH** ramp locks.

WARNING: Keep **ALL** personnel clear of the rear area of the trailer during **LOADING** or **UNLOADING** operations. **NEVER** operate **EITHER** load ramp with **ANY** person beneath **OR** in contact with **EITHER** ramp or their linkage.



c. **PULL** the **MAIN** ramp control valve handle to the **RAISE** position and **FULLY** raise the main ramp [SEE FIGURES 1-2 and 1-3].

CAUTION: The **MAIN** ramp **MUST** be **FULLY** raised, so that ground clearance is provided to swing the **APPROACH** ramp **UPWARD** from the stowed position and disengage the travel mechanisms for **BOTH** ramps. **IF** the trailer **IS** being loaded from a loading **DOCK**, **CHECK** for adequate clearance from the dock area to allow for the **APPROACH** ramp upward swing path. **IF** clearance is **NOT** adequate, remove the blocking from the trailer wheels and **MOVE** the tractor/trailer unit **FORWARD** to supply clearance for the **APPROACH** ramp to swing **PAST** the dock and into the **RAISED** position from under the trailer main ramp. **IF** the trailer **WAS** moved, back the tractor/trailer unit rearward into position, so that the **APPROACH** ramp **TIP** end will be **FULLY** supported by the **DOCK** when lowered. Put blocks under the trailer wheels at **BOTH** the front and the rear.



WARNING: Block the wheels securely.



SR SERIES TRAILER

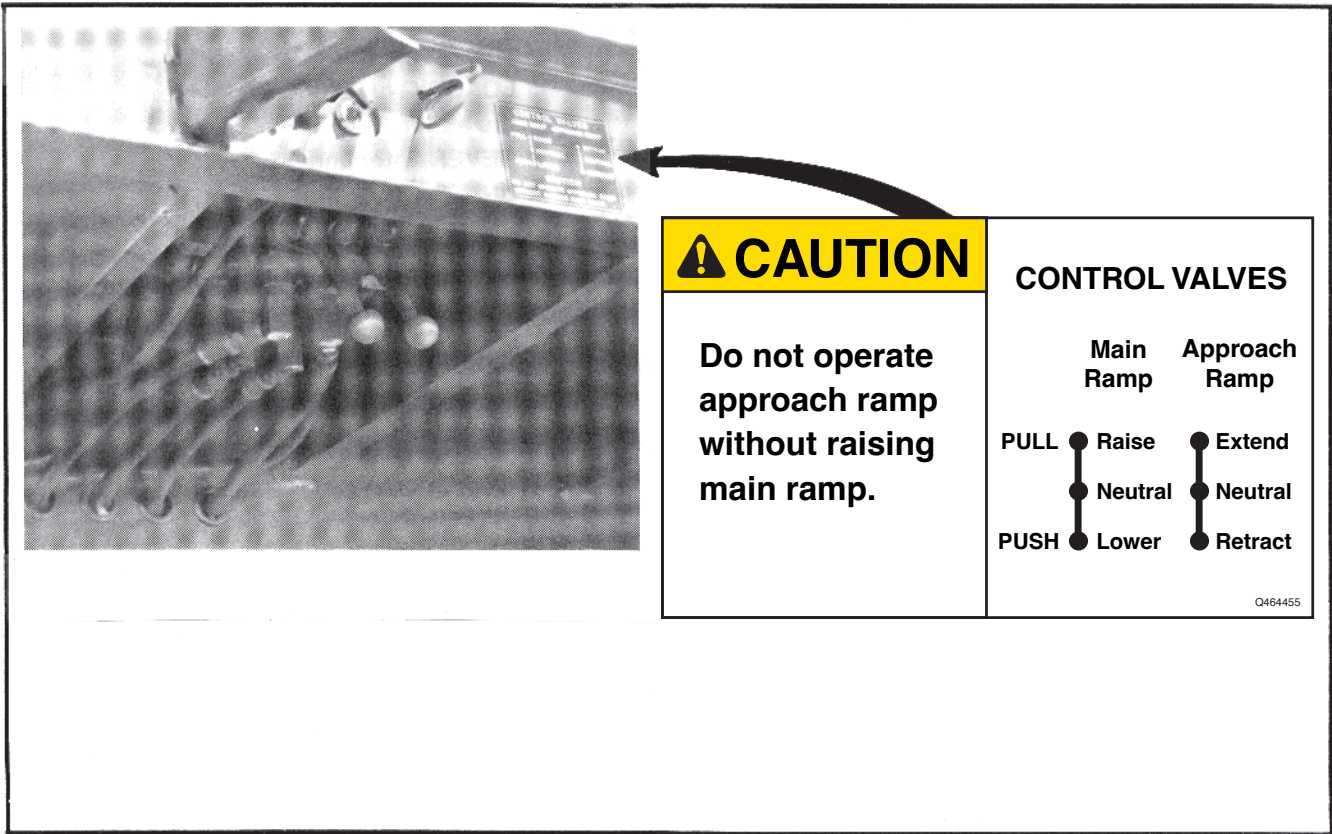

FIGURE 1-2. OPERATION DECAL - MODEL SR TRAILER - WITH MAIN AND APPROACH RAMPS ONLY.

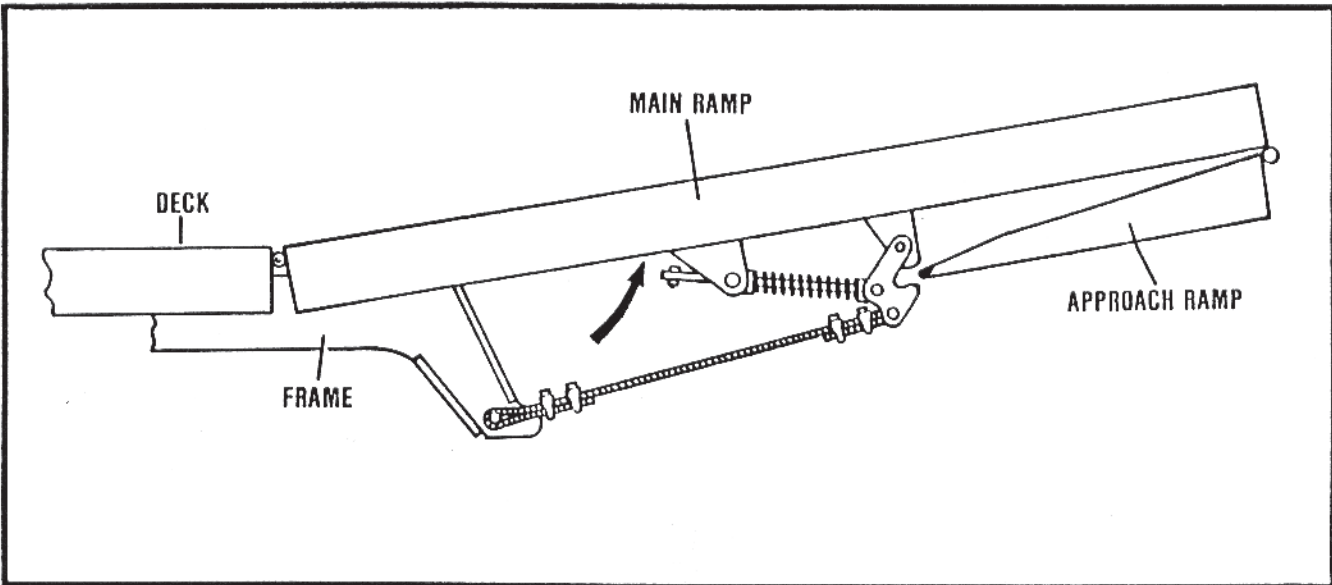

FIGURE 1-3. MAIN RAMP IN FULLY RAISED POSITION.

SR SERIES TRAILER

OPERATION

d. PUSH the APPROACH ramp control valve handle to the EXTEND position and FULLY raise and extend the APPROACH ramp [SEE FIGURE 1-2 and 1-4].

NOTE: Due to the manner the approach ramp hydraulic circuit is designed, “FEATHER” [slowly and ONLY partially move] the APPROACH ramp control valve operation handle, so that the power pack engine will NOT be overloaded.

WARNING: BEFORE extending the APPROACH ramp, be certain that an area at the REAR of the trailer at least eight [8] feet LONG and the FULL trailer width, is CLEAR of personnel and/or obstructions.
Serious injury to personnel and/or damage to the trailer will result if THIS “WARNING” is not observed.

CAUTION: The TIP end of the APPROACH ramp MUST be fully extended UPWARD. This will provide support of the APPROACH ramp tip by the loading dock OR the ground, AFTER the MAIN ramp has been lowered in step “e”.

e. PUSH the MAIN ramp control valve handle in the LOWER position and FULLY lower the MAIN and APPROACH ramps downward UNTIL the tip of the APPROACH ramp rests firmly on the ground OR loading dock [SEE FIGURES 1-2 and 1-5].

WARNING: Keep ALL personnel clear of the rear area of the trailer AND moving parts.

NOTE: IF the trailer is equipped with the OPTIONAL “HYDRAULIC GOOSENECK RAMP”, PULL the GOOSENECK ramp control valve handle to the RAISE position and FULLY raise the gooseneck ramp upward to the “LOAD” position [SEE FIGURE 1-6].

WARNING: Keep ALL personnel away from the gooseneck ramp while being raised.

f. Stop the power pack engine [IF so equipped] OR disengage the truck operated hydraulic pump and stop the truck engine.

g. Center the equipment with the center of the trailer width as the equipment nears the trailer APPROACH ramp. CAREFULLY and SLOWLY move the equipment onto the trailer approach ramp, up the load ramp and onto the trailer deck.

WARNING: Use care when loading the equipment onto the trailer. Move the equipment CAREFULLY and SLOWLY. Use extension brackets [OPTIONAL] to support wide loads. Extension brackets will NOT support full load weight.

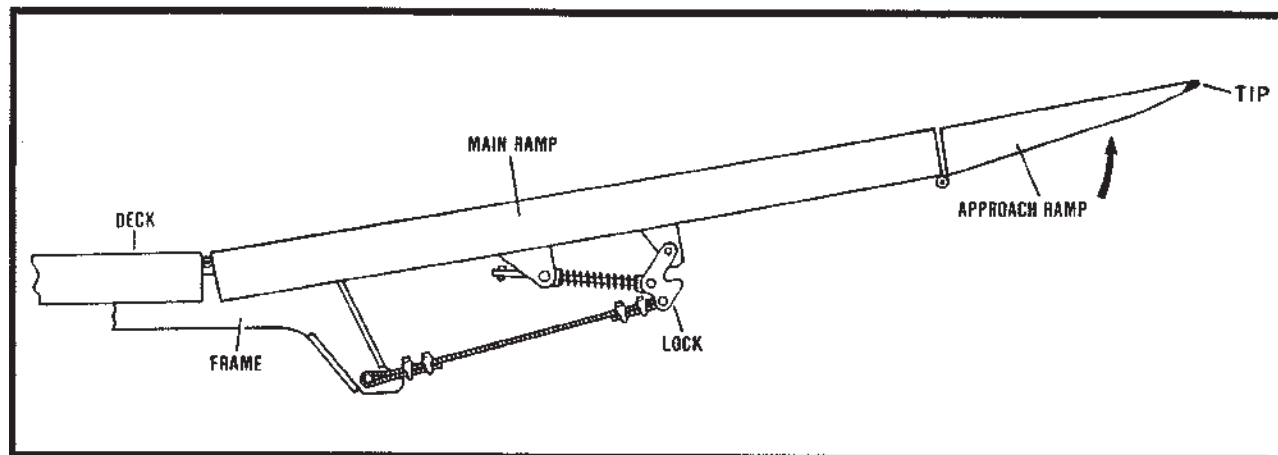

FIGURE 1-4. APPROACH RAMP IN FULLY RAISED POSITION.

SR SERIES TRAILER

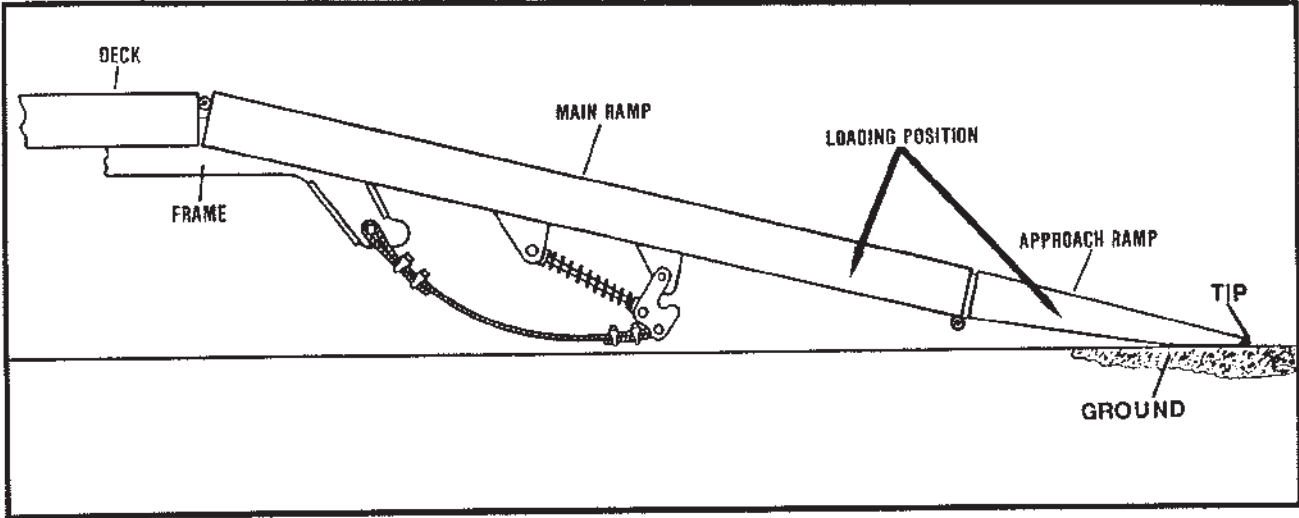

FIGURE 1-5. APPROACH AND MAIN RAMPS IN FULLY LOWERED POSITION.

 CAUTION	<h3>CONTROL VALVES</h3> <table border="0" style="margin-left: auto; margin-right: auto;"> <tr> <td></td> <td style="text-align: center;">Main Ramp</td> <td style="text-align: center;">Approach Ramp</td> </tr> <tr> <td style="text-align: center;">PULL</td> <td style="text-align: center;">● Raise</td> <td style="text-align: center;">● Extend</td> </tr> <tr> <td></td> <td style="text-align: center;">● Neutral</td> <td style="text-align: center;">● Neutral</td> </tr> <tr> <td style="text-align: center;">PUSH</td> <td style="text-align: center;">● Lower</td> <td style="text-align: center;">● Retract</td> </tr> </table>		Main Ramp	Approach Ramp	PULL	● Raise	● Extend		● Neutral	● Neutral	PUSH	● Lower	● Retract
	Main Ramp	Approach Ramp											
PULL	● Raise	● Extend											
	● Neutral	● Neutral											
PUSH	● Lower	● Retract											
<p>Do not operate approach ramp without raising main ramp.</p>	<small>Q464455</small>												

FIGURE 1-6. OPERATION DECAL - MODEL SR TRAILER - WITH MAIN, APPROACH, AND OPTIONAL HYDRAULIC GOOSENECK RAMPS.

NOTE: IF the trailer is equipped with the OPTIONAL "HYDRAULIC WINCH", and it IS being used to load the equipment onto the trailer, use the following special information, notes, cautions, warnings and dangers.

1. Put the hydraulic winch control valve handle in the "NEUTRAL" position (SEE FIGURE 1-7). Go to the WINCH ASSEMBLY and MOVE the spool disengagement handle to the DISENGAGE position. PULL the cable TO the equipment to be loaded onto the trailer. SECURELY fasten the winch cable to the equipment being loaded onto the trailer.

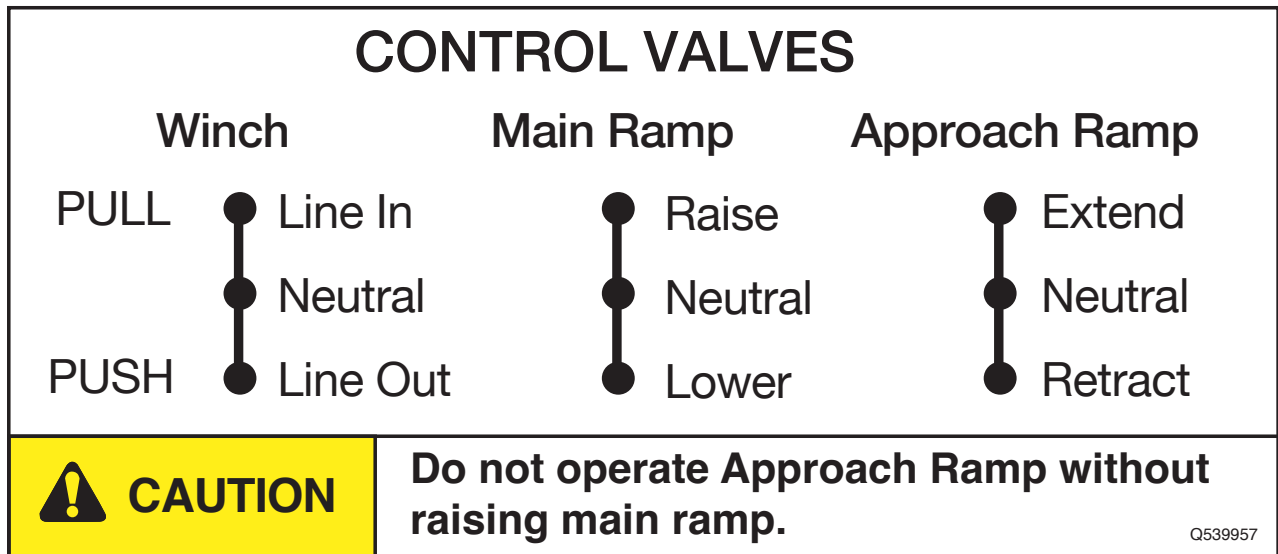

FIGURE 1-7. OPERATION DECAL - MODEL SR TRAILER - WITH MAIN AND APPROACH RAMPS AND OPTIONAL HYDRAULIC WINCH SYSTEM.

DANGER: Serious INJURY or DEATH can result from being struck by a broken or loose winch cable. The cable **MUST** be maintained in **GOOD** condition. Stay **CLEAR** of the cable. Fasten the cable **SECURELY** to the equipment.
The cable clamps **ALONE** on winches are **NOT** designed to hold loads. A **MINIMUM** of 5 wraps of cable **MUST** be left on drum barrel.

NOTE: Park the tractor/trailer in position, so that the approach ramp is centered to the equipment to be loaded onto the trailer.

2. Start the power pack engine [IF so equipped] OR start the truck engine and engage the truck operated pump.
3. Release the secondary/parking brake system on the equipment being loaded onto the trailer through the use of the winch.

WARNING: Clear the **COMPLETE** area around and near the trailer of **ALL** personnel. **DO NOT** operate a winch that has defects or damage. **DO NOT** work a damaged cable [broken wire or strands]. **DO NOT** stand, or allow other personnel to stand, near the winch cable at **ANY** time. **DO NOT** stand, or allow other personnel to stand, in the path of the cable, should a failure occur. **DO NOT** permit **ANY** personnel on the equipment being loaded onto the trailer **ONLY** trained and authorized personnel can operate the winch system.

4. Go to the **WINCH ASSEMBLY** and **MOVE** the spool disengagement handle to the **ENGAGE** position. **SLOWLY PULL** the **WINCH** system control valve handle to the **LINE IN** position and engage the winch drive (SEE FIGURE 1-7).

WARNING: As the cable comes under tension, **CHECK** to be sure that the hook remains securely fastened to the equipment and the winch cable has **NO** interference with **ANY** item.

SR SERIES TRAILER

5. KEEP the WINCH system control valve handle at the LINE IN position [SEE FIGURE 1-7]. CAREFULLY and SLOWLY move the equipment into the desired position on the trailer deck. Move the WINCH system control valve handle to the NEUTRAL position [SEE FIGURE 1-7].
6. Put the equipment secondary/parking brake system in the "ON" [APPLIED] condition AND SECURELY block the equipment from movement.
7. PUSH the WINCH system control valve handle to the LINE OUT position and release the tension on the winch cable [SEE FIGURE 1-7]. Move the WINCH system control valve handle to the NEUTRAL position and remove the cable from the equipment. PUSH the WINCH system control valve handle to the LINE IN position and wind the winch cable onto the drum. Move the WINCH system control valve handle to the NEUTRAL position.

WARNING: DO NOT pull the hook over the winch drum and through the throat of the winch.



When NOT operating the winch system, ALWAYS leave the WINCH system control valve handle in the NEUTRAL position [SEE FIGURE 1-7].

8. Stop the power pack engine [IF so equipped] OR disengage the truck operated hydraulic pump and stop the truck engine.

WARNING: IF the trailer is equipped with the OPTIONAL "GOOSENECK RAMPS", be SURE that the ramps are SECURELY fastened into the trailer load rail BEFORE driving the equipment onto the ramps and the gooseneck deck.



NOTE: IF the trailer is equipped with the OPTIONAL "HYDRAULIC GOOSENECK RAMP", CAREFULLY and SLOWLY move the equipment up the gooseneck loading ramp and into position on the gooseneck. PUSH the GOOSENECK ramp control valve handle to the LOWER position and FULLY lower the gooseneck ramp downward to the "TRAVEL" position [SEE FIGURE 1-6].

CAUTION: ALWAYS lower the hydraulic gooseneck ramp COMPLETELY against the trailer main deck BEFORE binding the equipment to the gooseneck deck. NEVER travel the trailer with the gooseneck ramp in a raised position from the trailer main deck. The gooseneck ramp will NOT be in a locked condition and will lower during travel. This will permit the equipment binding devices to loosen [SEE FIGURE 1-10].



WARNING: Keep ALL personnel away from the gooseneck ramp while being lowered.



h. Put the equipment secondary/parking brake system in the "ON" [APPLIED] condition. STOP the engine. SECURELY fasten EACH and ALL equipment, which is loaded on the trailer, to the trailer frame with chains and binding devices.

WARNING: ALL equipment MUST be securely and adequately fastened to the trailer as directed by the EQUIPMENT MANUFACTURER.



NEVER raise the APPROACH ramp OR move the trailer with equipment on the APPROACH ramp. The APPROACH ramp will NOT support a load in a RAISED condition [SEE FIGURE 1-8].

i. Start the power pack engine [IF so equipped] OR start the truck engine and engage the truck operated pump.



FIGURE 1-8. CAUTION DECAL - MODEL SR TRAILER - APPROACH RAMP.

j. PULL the MAIN ramp control valve handle in the RAISE position [SEE FIGURE 1-2]. FULLY raise the MAIN and APPROACH ramp FROM the ground OR loading dock.

CAUTION: IF the trailer WAS loaded from a loading DOCK, remove the blocking from the trailer wheels and MOVE the tractor/trailer unit FORWARD to supply clearance for the APPROACH ramp to swing PAST the dock and into the TRAVEL position under the trailer main ramp, in step “k”.
DO NOT lift the MAIN and APPROACH ramps with a load on the APPROACH ramp [SEE FIGURE 1-8].

k. PUSH the APPROACH ramp control valve handle to the RETRACT position [SEE FIGURE 1-2]. FULLY lower the APPROACH ramp into the TRAVEL position under the trailer main ramp UNTIL a distinct “BUMP” is heard and the APPROACH ramp is AGAINST the stops.

WARNING: Keep ALL personnel clear of the rear area of the trailer AND moving parts. BEFORE lowering the APPROACH ramp, be certain that an area at the REAR of the trailer at least eight [8] feet LONG and the FULL trailer width, is CLEAR of personnel and/or obstructions. Serious injury to personnel and/or damage to the trailer will result if THIS “WARNING” is not observed.

SR SERIES TRAILER

l. PUSH the MAIN ramp control valve handle to the LOWER position. Lower the MAIN ramp downward UNTIL the MAIN ramp is SECURELY against the compression blocks [SEE FIGURE 1-2].

m. Visually INSPECT and insure that the main ramp compression blocks AND approach ramp travel locks are correctly engaged [SEE FIGURE 1-9].

WARNING: DO NOT move or use the trailer IF the locks are NOT correctly locked, UNTIL the fault is corrected.
DO NOT move or use the trailer with the APPROACH and/or MAIN ramp in the “UP” position .

n. Stop the power pack engine [IF so equipped] OR disengage the truck operated pump. Remove the blocks from the trailer wheels.

Maintenance

General

This section contains instructions for the care and maintenance of the Etnyre RS trailer. This section is divided into two subsections: a **Maintenance Schedule** and **Maintenance Procedures**. The maintenance schedule lists the recommended distance/time intervals between maintenance checks. The procedures subsection provides detailed instructions for performing the maintenance checks. The instructions listed in the procedures subsection are given by systems and are not necessarily in the order listed in Table 2.

Maintenance Schedule

Table 2 lists the recommended maintenance checks. It is outlined in two schedules: the mileage schedule and the periodic schedule. Perform maintenance on the basis of whichever occurs first.

The first column of Maintenance Table 2 should be used to locate the applicable maintenance procedure and illustration. Figure 8 shows the maintenance points.

ITEM NO.	ITEM	SCHEDULE					QUAN	TYPE or REMARKS
		Day	Wk	Mo	25,000 mi. or 6 mo	50,000 mi. or 1 year		
1	5th Wheel Plate Kingpin	X	X					Multipurpose Grease No .1 (No. 0 Below 32°F) Inspect
2	Frame & Decking		X					Check
3	Undercarriage		X					Check
4	Wheel Bearings (Oil Lubricated)	X				C	3 Pints per axle (1.42 liter)	Multipurpose Gear Oil Grade 90
5	Rims & Brake Drums			X				Inspect
6	Wheels	X	X					Visual Check. Tighten Lug Nuts or Rim Clamps
7	Tires	X						Check Inflation & Remove Debris Between Duals
8	Air Lines	X	X					Test Inspect
9	Air Reservoir	X					2	Drain Condensation
10	Relay Emergency Valve					X	1	Clean
11	Brake Chambers			X		X	2 per axle	Check Condensation Holes Clean. Inspect & Replace Diaphragm
12	Slack Adjuster and Yoke Pin				X			Inspect

Table 2. Maintenance Schedule

ITEM NO.	ITEM	SCHEDULE					QUAN	TYPE or REMARKS
		Day	Wk	Mo	25,000 mi. or 6 mo	50,000 mi. or 1 year		
13	Brakes	X	X		X		8 per axle	Multipurpose Grease Note: Do Not over-grease Brake Spider (or Anchor Pins when applicable) Check for Overheating Inspect & Adjust
14	Lights & Reflectors	X						Check Operation
15 - with Power Pack	Hydraulic Oil			X		X	13.4	SAE 10W Hydraulic Oil
16 - with Power Pack	Hydraulic Filter Element					X	1	Period Shown or 50 hours of Power Pack Operation - See Parts Manual.
3	APPROACH Ramp Hinge Pins		X				4	Lubricate ALL ramp hinge pins with <i>Extreme Pressure</i> grease #1
4	APPROACH Ramp Cylinder Rod End		X				1	Lubricate cylinder <i>rod</i> end with <i>Extreme Pressure</i> grease #1
1	APPROACH Ramp Locks	X					2	Check for correct lock operation
2	MAIN Ramp Compression Blocks AND Linkage	X					2	Check for correct block AND linkage operation
3	APPROACH Ramp Hinges and Linkage	X					ALL	Check ramp hinges and linkages at ALL points for correct operation and structural integrity
3	APPROACH Ramp Hinges and Linkage	X					ALL	Check ramp hinges and linkages at ALL points for correct operation and structural integrity

*** WARNING: DO NOT operate OR use the trailer, IF ANY fault in operation OR wear and/or part defects are noted, UNTIL the fault or defects have been COMPLETELY CORRECTED.**



X = CHECK/LUBRICATE/SERVICE C = CHANGE

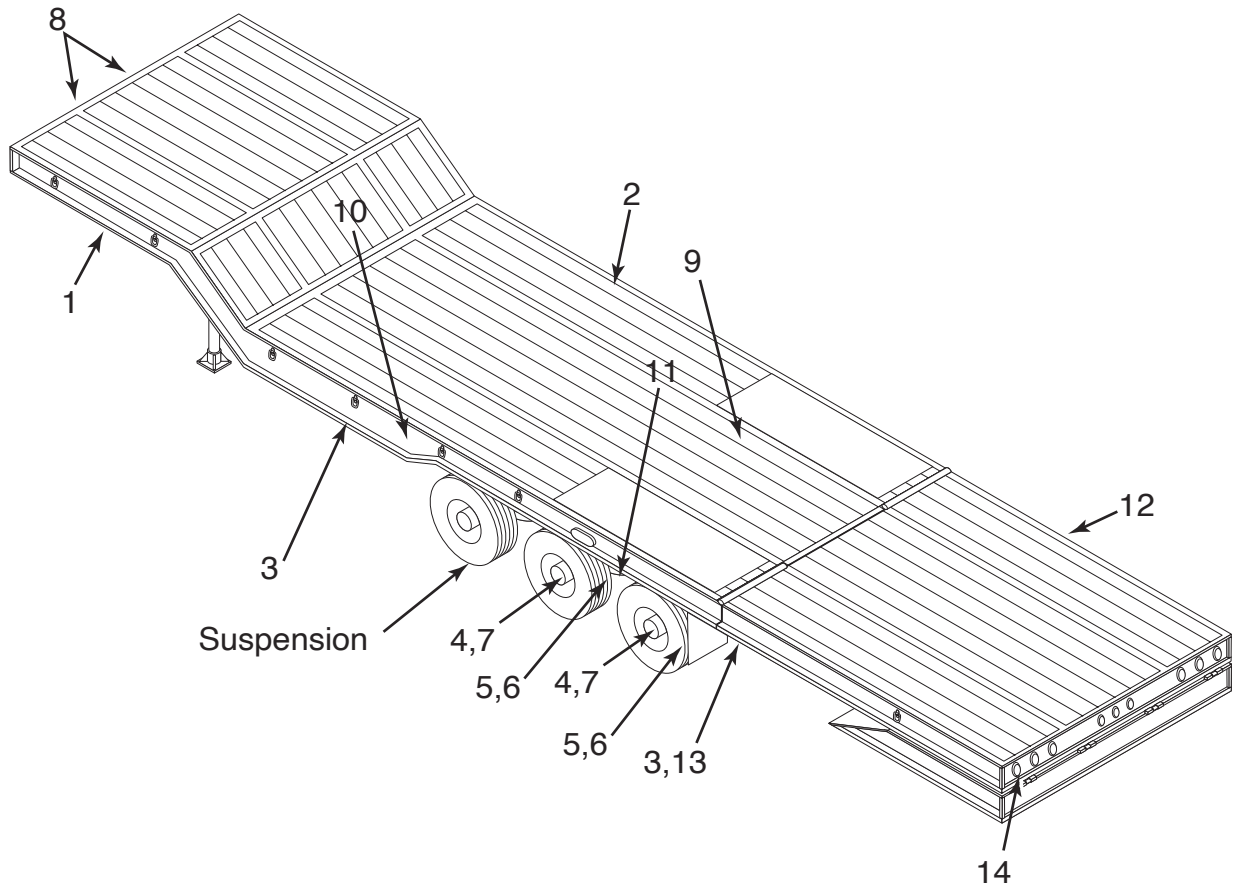

Figure 8. Maintenance Checkpoints

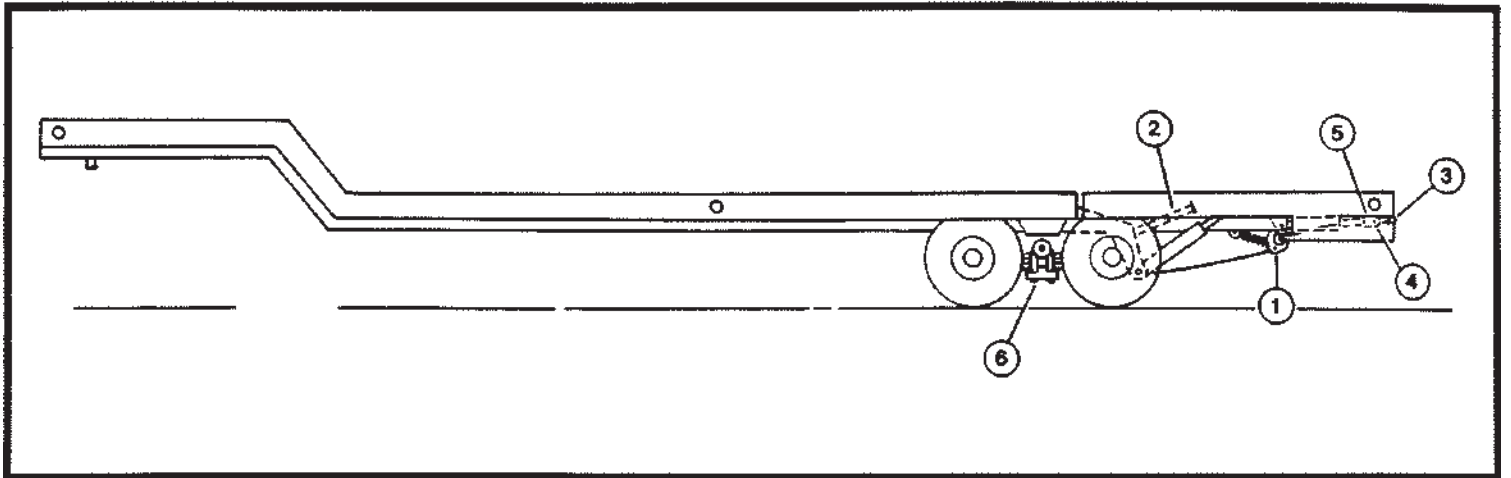

FIGURE 1-11. MODEL SR TRAILER - MAINTENANCE CHECK, LUBRICATION AND SERVICE LOCATIONS.

Maintenance Procedures

Fifth Wheel Plate and Kingpin Inspection and Lubrication

Inspect the kingpin throat for signs of wear. Replace the kingpin if worn 1/8 inch (3.18 mm) undersize (see figure 5).

If the grease remaining on the fifth wheel plate contains sand and dirt, clean it before lubricating. The kingpin and the fifth wheel plate should be greased thoroughly with multipurpose grease before connecting the tractor and trailer.

Frame Inspection

An important phase of trailer maintenance is the inspection and repair, if required, of all structural members of the trailer frame. The frame must be one solid unit to carry the load. This also helps prevent major repair costs and trailer downtime.

Complete frame inspection is required for various reasons. Trailers are subjected to considerable abuse due to heavy loads and difficult road conditions under which they are operated. A trailer loaded to the maximum rated capacity and pulled at the highest rated speeds for long periods of time, could develop structural damage faster than a trailer carrying lighter loads at lower speeds. Rough use and poor maintenance will shorten the life of the trailer.

Check the trailer frame daily for cracked structure, cracked welds, and broken, damaged or lost parts. Structural cracks will usually show best when the trailer is loaded. Failures are the result of metal fatigue caused by flexing and vibration. They will appear as cracks in the steel frame members. If repairs are needed, do not operate the unit until the repairs are made. Structural

repairs must be done by persons experienced in this field.

NOTE: Failure to maintain decking in good condition may cause damage to crossmembers.

Weld Repairs

Minor repairs to crossmembers, floorplates, and other parts which are not part of a main structural member, may be repaired without special instruction *if good welding practices are followed.*

 WARNING
Repairs to major structural members must be made according to the requirements of the part being repaired. Care must be taken to ensure that the repairs do not contain stress concentrations which could lead to another failure. Repair of T-1 steel especially requires additional care.

Table 3 lists the recommended electrodes for the various steels used in Etnyre trailers.

Wheel Bearings

The oil level must be maintained between the "add" and "full" lines on the hub cap windows (see figure 9). Check for cracked windows, missing vent plugs and for oil leaks around the hub cap. Oil can be added through either the vent plug or the filler plug. Clean and inspect the bearings and change the oil at 50,000 miles or at brake relinings.

Type of Steel	Position of Work	AWS Electrode	Usual Size
Carbon and High Strength	Vertical, Overhead & Flat Position	E6013 E7014 E7018*	3/16"
T1 Alloy	Vertical, Overhead & Flat Position	E7018* E8018* E11018* *Low Hydrogen	3/16

Table 3. Electrodes for Weld Repairs.

Undercarriage

The undercarriage must be visually examined for broken and missing parts. Check brackets, adjusting screws and walking beam ends. Replace faulty parts. Check the rim clamps or cap nuts for tightness daily. See Figure 10 for torque specifications and tightening sequence. Brake drums should be carefully examined for cracks.

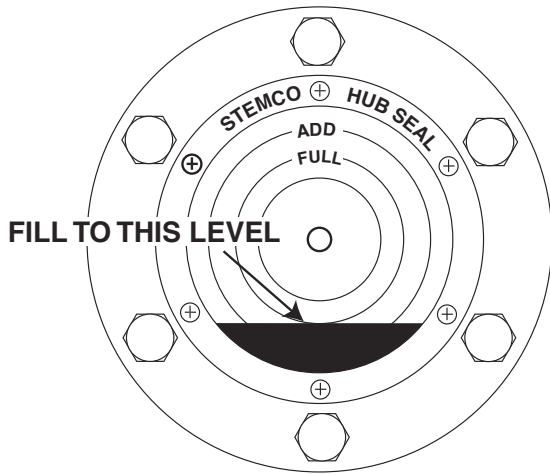
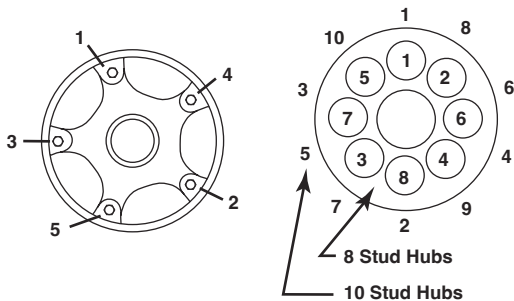

Figure 9. Check Oil Level of Oil Lubricated Bearings.

CAUTION

Do not allow brake drums to become excessively worn or expensive repairs will be required.



Tighten Lug Nuts to recommended torque using sequence shown

Torque Value
3/4" nuts - 180/200 Ft Lb
M22 x 1.5 nuts - 450/500 Ft Lb

Figure 10. Tightening Sequence

Service Guide - Ridewell Suspensions

Basic Operation

When properly maintained and operated within design limits, Ridewell's Monopivot 240 Suspension will provide many years of trouble-free service. It has several unique features which keep maintenance and downtime to an absolute minimum:

1. A Double-Bonded, manual clamp-in pivot bushing.
2. A patented, contoured weld-on axle seat that requires no U-bolts.
3. A patented eccentric bolt for simple, manual axle alignment.
4. A longer hanger that minimizes kingpin slap by improving geometry between pivot bushing and axle center.
5. A self-contained shock absorber that allows precise installation and insures proper shock and air spring tolerances.

Air Springs & Height Control Valve

This air-ride suspension is designed to dampen the shocks transmitted from road surface to trailer frame through the Air Springs. The Height Control Valve is used to maintain the proper ride height from air spring to chassis (whether empty or loaded) by controlling the volume of air in the springs.

You may use either a single or dual (leveling) height control valve system on your trailer. This service manual addresses the Single Valve System which controls ride height only. A manual or automatic dump valve may also be incorporated to exhaust air to prevent "dock creep" when loading or unloading.

Important Note: The air springs used on the Monopivot 240 have internal rubber bumpers designed to carry the trailer load should air spring failure or sudden loss of air supply occur. Should an air spring fail on a "single height control valve system," then all of the air springs will deflate allowing the suspension to operate on internal bumpers until repairs can be made. Should an air spring fail on a "dual height control or leveling valve system," the springs would deflate on one side only. Simply deflate the other side by removing the vertical linkage rod from the valve and rotate the horizontal lever arm DOWN to fully exhaust the spring.

Air Pressure & Brake Protection Valve

This air-ride suspension is dependent on air pressure from the trailer supply system. Air pressure must be maintained above 65 P.S.I. before operation. A Brake Protection Valve must be installed in the air system to prevent air loss below 65 P.S.I. and to insure safe air brake pressure in the event of air loss in the suspension system.

Operational Inspection

1. Inspect all welds at hanger-to-frame connections.
2. Inspect for proper installation of cross member between hangers. Hangers should be adequately supported to prevent side movement.
3. Inspect axle to lower beam weld. Axle should be snug in contoured axle seat and welded according to guidelines shown in Figures 12, 13 and 14.
4. Inspect axle alignment to kingpin. Forward axle should be $\pm 1/16$ " left to right relative to kingpin. Rear axle, if equipped, should be in line with forward axle $\pm 1/16$ " axle center to axle center. Refer to axle alignment procedure shown in Figure 15.
5. Inspect automatic air control valve for proper installation. Valve should be mounted so linkage is free to operate without interference. Check all linkage connections and air fittings on valve for tightness. Refer to Figure 20.
6. Inspect air spring. With unloaded trailer on level surface and supply air pressure in excess of 65 P.S.I., all air springs should be of equal pressure. Check for proper clearance around air spring: minimum 1-3/4".
7. Inspect for proper mounting height. If measurement is incorrect, adjust height control valve until proper mounting height is achieved.
8. Check all air connections for leaks and tighten if needed.
9. Inspect air lines. They should be free from sharp objects and secured to prevent premature failure.
10. Eccentric bolt inspection: (See Figure 11)

Inspect for installation of anti-turn washer for proper welding as shown at right.

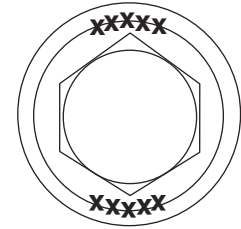

1/4" Fillet Welds,
1" Long, After Axle
Is Aligned.

Figure 11. Eccentric Bolt Inspection

Preventive Maintenance

Daily

Visually inspect trailer to be sure it is level and that suspension ride height is correct.

Check for loose or broken parts on or around suspension to prevent any serious problems from occurring.

Every 30 Days

Check clearances around all moving suspension parts, air springs, tires and shock absorbers. Any signs of interference should be immediately corrected.

Visually inspect axle connection weld and bolt connections to make sure they are secure. Review and correct any signs of wear.

Every 90 Days & With Annual Inspection

Check items mentioned above in Daily & 30 Day inspections.

Also inspect weld integrity at the following connections: suspension-to-axle, anti-turn washer, locking plate and hanger-to-frame.

All pivot and clamping connections such as the suspension pivot and the shock mounting must be inspected. All pivot and clamping connections such as the suspension pivot and the shock mounting must be inspected.

NOTICE!! Ridewell Corp. Bears no responsibility for suspensions damaged by abuse or neglect. In addition, any suspensions driven to complete destruction will not be covered by warranty.

Welding Guidelines

The following precautions and recommendations must be read and understood by qualified personnel prior to weld installation of Ridewell Air-Ride Trailer Suspensions to trailer axles. Any welding procedures or materials that do not clearly fall within these guidelines could compromise the integrity and safety of the installation.

Welding Methods, Materials & Personnel

A) All welders and welding operators should be certified per A.W.S (American Welding Society) D1.1 Section 5 Procedures or equal.

B) Recommended welding methods are shielded metal arc (stick), gas metal arc (solid wire) or flux cored arc (tubular wire) welding. Whatever electrode and method used must develop a minimum weld tensile strength of 70,000 P.S.I. Refer to the electrode manufacturer's recommendation for voltage, current and shielding medium for the diameter electrode to be used so the best fusion and mechanical properties can be obtained.

C) All electrodes used should meet A.W.S. Section 5 Specifications and Classifications for welding carbon and low alloy steels.

D) If shielded metal arc electrodes (stick) are used, they must be new and unused, dry, free of contaminants and come from a stock that has been purchased and stored per A.W.S. Section 4.5.2., Low Hydrogen Electrode Storage Specifications.

Weld Joint Preparation

A) **All grease, dirt, paint, slag or other contaminants must be removed from the weld joint without gouging the axle tube.**

B) Insure the lower beam assembly fits the axle with a weld root gap of 1/16" to 1/8" maximum between the welding wings or uprights as illustrated. (See Figure 16.)

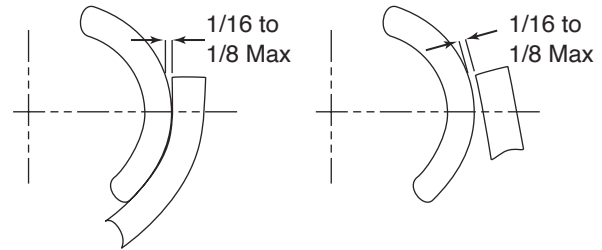

Figure 12. Root Weld Gap

Welding Procedure

A) Ground the axle to one of the attached axle parts such as the air chamber brackets, cam brackets, or the brake spider. **Never ground the axle to a wheel or hub as the spindle bearing may sustain damage.**

B) The axle assembly should be at a minimum temperature of 60° F (15° C) prior to welding. **Pre-heating the weld zone to the axle manufacturer's recommended pre-heat temperature is recommended.** This will minimize the formation of martensitic or brittle metal structures in the fusion line or the heat affected zone which may contribute to a premature fatigue failure in service.

C) The joint to be welded should be positioned in the flat or horizontal position if possible.

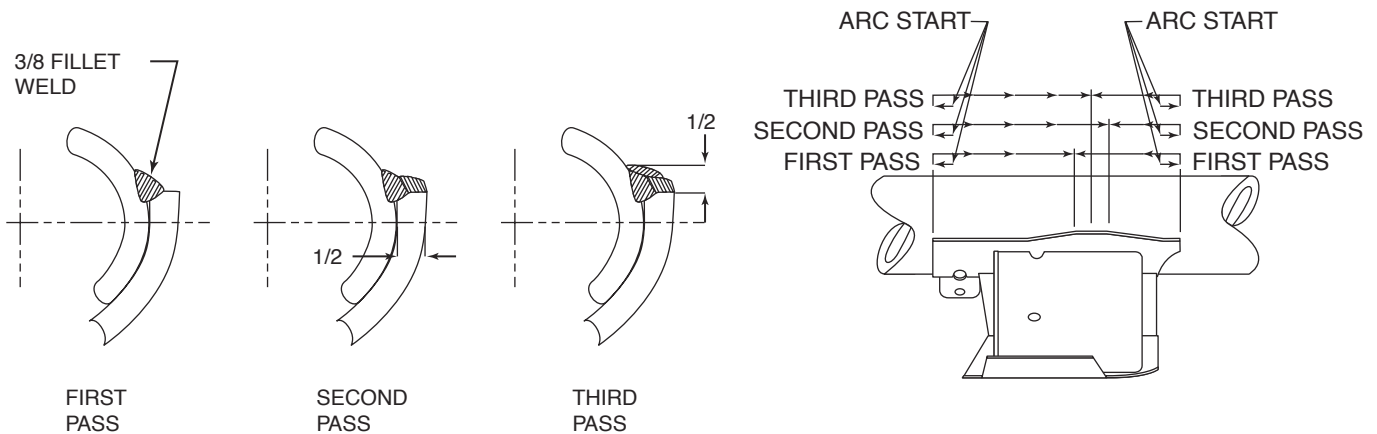

Figure 13. Multiple Pass Recommended Method

D) Multiple pass welding may be used on the beam/axle connection using the following guidelines. Total fillet weld size should be 1/2" (12.7mm).

Multiple pass (recommended method, SMAW, GMAW, FCAW) weld initiation and termination should be performed as outlined and shown in (Figure 13).

NOTE: All slag must be removed between passes. Backstep fill all craters. Each pass must be accomplished in two segments. Recommended electrode is E7018 if SMAW (stick) is used.

IMPORTANT: It may be necessary to C-clamp axle to axle beam seat prior to welding. This will insure that complete contact occurs between the axle housing and beam seat.

Repair Welding

If the beam/axle weld is cracked or broken, the weld

can only be repaired if the crack or break does not extend into the axle tube. To repair the weld, grid or back gouge the weld/crack down to the base metal. If the crack extends into the axle tube, or if any other area of the axle is cracked, the axle must be replaced. Apply the repair weld according to the information in Sections 1-3 of the guideline.

Welding Precautions

A) All welds must be kept away from the top and bottom of the axle where maximum stresses occur. The "no weld" zones are illustrated in (Figure 14).

B) **Do not test weld the arc on any part of the axle tube.** This can cause a material change which can lead to a small crack that may eventually grow and affect the fatigue life of the axle.

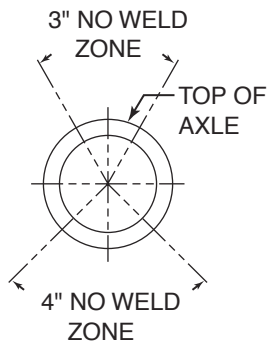

Figure 14. No Weld Zones

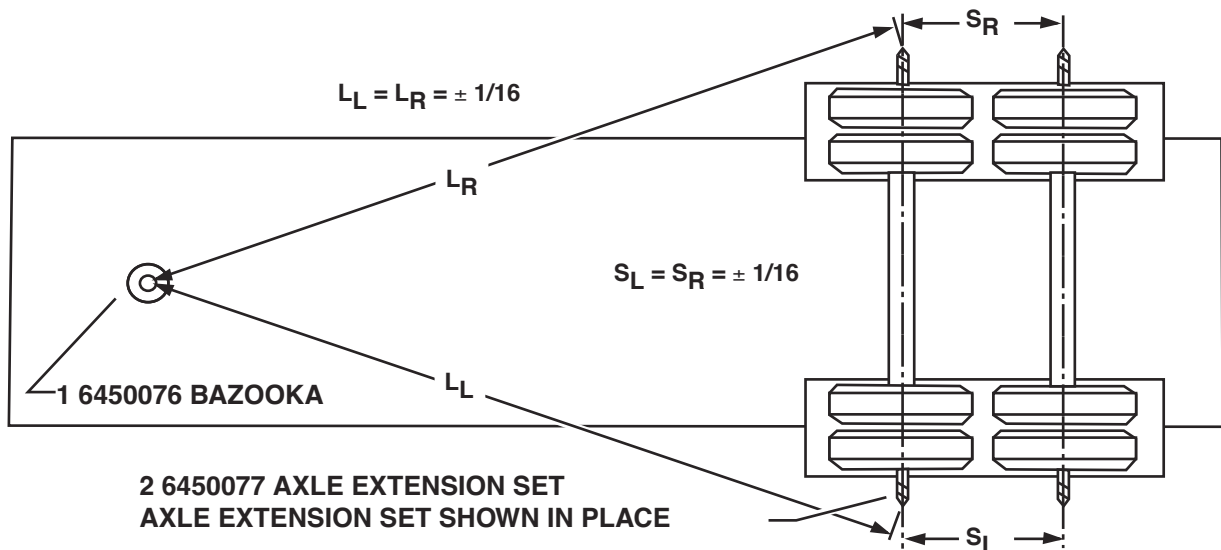

Figure 15. Alignment of Axle

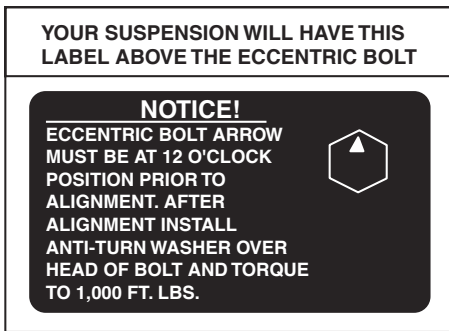

Figure 16. Hanger Sticker

Alignment Of Axle

The Monopivot 240 is equipped with an eccentric bolt in one or both hangers for simple, manual alignment of axles. (See Figure 16)

For Tandem Axle Trailer

1. Align the forward axle to center of kingpin (see "A" in Figure 15), then align rear axle to center of forward axle (see "B" in Figure 15). The measurement from left to right side of axle centers should not exceed 1/8" difference.
2. To align the axle, loosen the eccentric bolt lock nut and remove the anti-turn washer from head of eccentric bolt.
3. To move the axle forward, rotate the eccentric bolt arrow toward the front of the trailer. The bolt may be rotated a maximum of a 1/4 turn from top center.
4. To move the axle rearward, rotate the eccentric bolt arrow toward the rear of the trailer. The bolt may be rotated a maximum of a 1/4 turn from top center.
5. After alignment is achieved, re-install anti-turn washer and weld at positions as shown in figure 15. Re-torque the eccentric bolt lock nut to specified torque.

Height Control Valve

Operation (See Figure 17)

As load is applied, the horizontal actuating lever arm moves from **NEUTRAL** position to **UP (intake)** position. As load is removed, the horizontal actuating lever arm moves from **NEUTRAL** position to **DOWN (exhaust)** position. The valve opens and air is allowed to exhaust from air springs bringing the horizontal actuating lever arm back to a neutral position. Optimum performance is achieved when valve is adjusted accurately to the suspension by increasing or decreasing horizontal lever arm length to a point where valve and lever arm approach 45° maximum, up or down from neutral position.

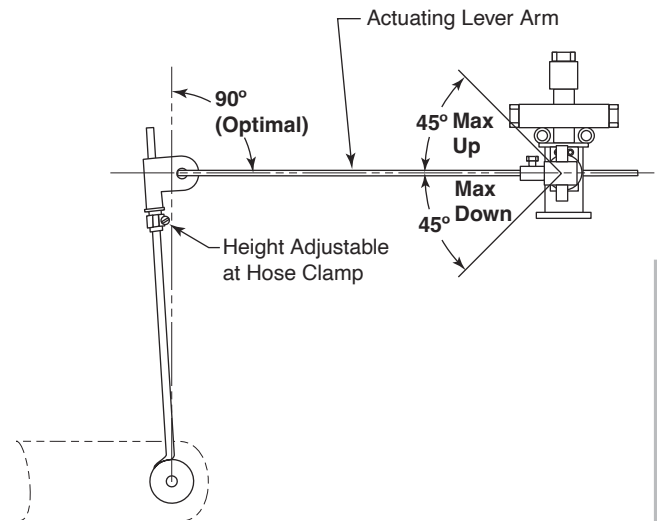

Figure 17. Height Control Valve Asm

Set Up

1. Insert vertical link rod through offset dampener link. Do not tighten clamp until final adjustment (discussed in **ADJUSTMENT** section) is made.
2. Insert horizontal lever arm through 5/16" cap screw side of insert to desired length. Tighten 5/16" cap screw to 10 Ft. Lbs.

NOTE: The horizontal actuating lever arm can be adjusted in length. The recommended length is 7", however a maximum length of 11-1/2" is acceptable.

A right or left-hand valve can be achieved by simply rotating the horizontal lever arm 180°.

Adjustment

1. With vehicle on level ground, build and maintain supply air pressure in excess of 65 P.S.I.
2. Rotate horizontal lever arm **DOWN** to exhaust air spring or rotate **UP** to inflate springs until proper ride height is achieved. Place lever arm at neutral position and insert wood centering pins into valve.
3. Slide vertical link rod through hole in the offset dampener link. Install vertical link rod grommet to pin on mounting bracket at axle. Place mounting bracket on axle and attach. Tighten clamp on offset dampener link and remove wood centering pins.
4. **TEST:** Disconnect vertical link rod grommet from mounting bracket at axle pin. Rotate horizontal lever arm **DOWN** to exhaust air springs about half-way.

Rotate horizontal lever arm **UP** until grommet is at axle mounting bracket pin level. Air springs should re-inflate to ride height level.

5. Re-connect grommet to pin, Check to see if air springs are of equal firmness.

6. Trim off excess vertical link rod "stick-out" past the offset dampener link if needed for proper operation. **CAUTION: Vertical link rod must extend completely through offset dampener at all times.** Also trim excess rod on horizontal lever arm.

Valve Replacement

1. Build and maintain supply air pressure in excess of 65 P.S.I.
2. Disconnect lower anchor.
3. Move actuating lever arm up-air should flow into related air springs.
4. Move actuating lever arm to neutral position-air flow should stop.
5. Move actuating lever arm down to exhaust air.
6. Move actuating lever arm to neutral position-air flow should stop.
7. Valve is functional if performance is as noted.

Tires And Disc Wheels

Tire Inflation

Proper and improper inflation will produce the tire section and ground contact characteristics shown in Figure 18. Tire inflation must be checked daily while tires are cold.

Either over-inflation or under-inflation will cause premature tire failure

CAUTION
<p>Do not attempt to adjust the inflation pressure while the tires are hot.</p>

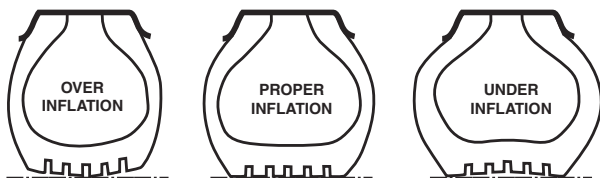

Figure 18. Proper Tire Inflation

CAUTION
<p>Do not exceed the cold inflation pressures. In some cases the rim will have a lower inflation pressure than the tire, in which case the lower pressure must be used. The maximum inflation pressure to be used is shown on the certification label. Tire inflation must be checked during road stops to locate air losses. Also, remove any foreign objects jammed between the dual wheels.</p>

CAUTION
<p>Repair any leaks immediately. All tires must be equipped with valve caps.</p>

Tire Overinflation

Overinflation weakens the cord body of the tire by reducing it's ability to absorb road shocks.

Overinflation can cause failure due to fatigue cracks.

Overinflation can also cause rim and wheel damage.

1. Inflate to correct pressure when tires are cool.

WARNING
<p>Do not overinflate tires.</p>

2. Never "bleed" tires to relieve excessive pressure buildup when the tires are warm. Excessive buildup of air pressure can be due to load, underinflation, speed or a combination of the three.

Tire Underinflation

Underinflation causes rapid wear and premature failure. Underinflation or overloading of the tires on any vehicle driven at sustained speeds will result in weakening of the tire cords. This can make the tire susceptible to further damage or failure even under normal load and inflation conditions.

WARNING
<p>Do not overinflate tires.</p>

Matching Dual Tires

Matching of the duals by size will result in longer tire life. Improper matching will cause the larger diameter tire to carry an overload. This will cause typical overloaded tire difficulties. The smaller diameter tire will also wear more rapidly due to scuffing. Differences of not more than 1/2 inch (6.35 mm) in diameter or 1-1/2 inch (19.1 mm) in circumference are allowed.

NOTE: The smaller of the two tires should be mounted in the inside position.

Removing Tire and Disc Wheel Assembly

WARNING

Before removing the tire and rim assemblies, remove the valve core and exhaust all air from both tires in the dual assembly. Check the valve stem by running a piece of wire through the stem to make sure it is not plugged.

With the trailer supported by jacks and blocks, remove all the air from the tires (see Warning on this page). Remove the cap nuts (see Figure 19). Remove the outside tire and disc wheel. Remove the inside tire and disc wheel if it must be changed.

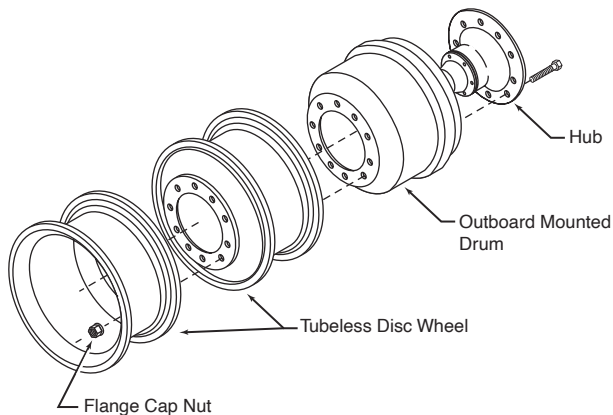

Figure 19. Removal of Tires and Hub Piloted Disc Wheels

Mounting and Demounting Tires on Disc Wheels

WARNING

Mounting and demounting of tires must be done by trained personnel only!

Always use industry approved procedures.

The following points must be considered when changing or repairing tires on disc wheels.

1. Do not mix rim or wheel components. They may come apart during inflation.
2. Check the rim base, side rings and lock rings for cracks or other damage. Do not attempt to repair disc wheels. Scrap damaged parts.
3. Match the duals.
4. Use only correct rim sizes.
5. Keep rims clean and painted to avoid corrosion.
6. Use proper valve stems and extensions. If valve spacers are used, be sure they are in place before reassembling.
7. Do not overinflate tires.

WARNING

Use properly constructed cages, guards or baskets when inflating tires.

Tires are to be mounted by trained service personnel only!

8. When the tires are worn, the tube will also be worn. Replace the tube. Use the proper size tube.
9. Replace chafed, pinched, stretched or creased tubes.
10. Replace twisted, creased or folded flaps.

Mounting Tire and Hub Piloted Type Disc Wheels

Before mounting the disc wheel, clean the mounting face of dirt and excess paint.

Place the inside tire and disc wheel assembly on the hub. Place the outside tire and disc wheel assembly on the hub and start the flange nuts. Valve stems for the two wheels should be mounted in different circumferential positions for easy inflation. Tighten the flange nuts to the torque and in the sequence shown in Figure

10. If the inside tire and disc wheel assembly was not removed, inflate the tire to the proper pressure.

Checking Tightness on Mounted Dual Disc Wheels

Check the flange nut, torque after the first 50-100 miles of service. Tighten the nuts as shown in Figure 10.

Hubs

Hub Removal

Demountable disc wheels must be removed before removing hubs. Support the hub assembly prior to removal. The hub and drum are removed as an assembly using the following procedure.

1. Loosen the brake adjustment by turning the adjusting screw on the slack adjuster.
2. Remove the hub.
3. Bend the flap or tang of the lockwasher from the flat of the outer spindle nut.
4. Remove the outer spindle nut, two (2) lockwashers and the inner spindle nut.
5. Pull the hub and drum assembly carefully to avoid damage to the bearing, spindle and inner seal. Catch the bearing cones as the hub is removed from the spindle.

Inspection and Cleaning

While the hub is removed, inspect the condition of the brake drum and linings. Also check the condition of the cups, cones, seal and axle ring.

Preparing Bearing for Assembly

Coat the bearing cones and cups with oil prior to assembly.

Hub Installation

After the parts have been cleaned, inspected and bearings oiled, install as follows:

1. Assemble the inner cone and seal into the hub.
2. Place the hub over the spindle, being careful to avoid damage to the spindle, seal and brake.
3. Put the outer cone into position.
4. Tighten the inner spindle nut while rotating the hub both directions until a slight bind is felt.
5. Loosen the nut 1/4 turn. The hub must rotate freely.
6. Install the inner nut lock and place the outer lockwasher on the spindle.

7. Tighten the outer nut.

8. The end play must be .001 in. (.0254 mm) to .010 in. (.254 mm).

9. Lock the outer spindle nut in place by bending the tangs or edge of the lockwasher over one flat on the outer nut.

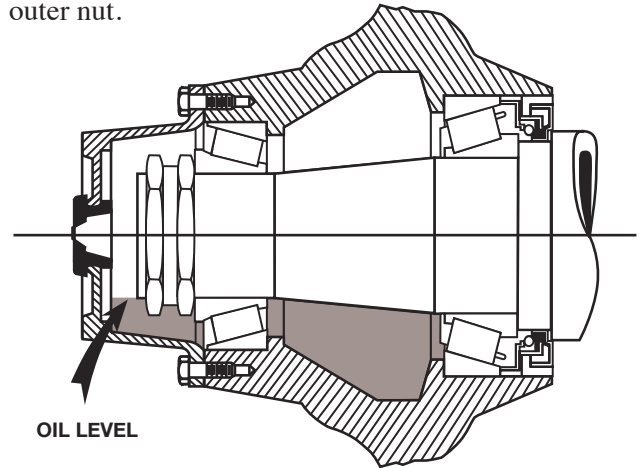

Figure 20. Checking Oil Level in Hub

10. Install the hub cap gasket and hub cap. Fill the hub to the "Full" line on the hub cap window (see Figure 9 & Figure 20).

11. Adjust the brakes.

Air Systems and Brakes

Air Systems and Brakes - General

This section contains a description of the operation of the trailer brake air supply system.

Also included in this section are test instructions, disassembly and assembly procedures and a troubleshooting guide.

Air System Tests

A series of tests must be run daily before operating trailers with air brakes.

1. Connect the air lines, turn on the air, and pressurize the system. The system must hold 100 PSI (7 Bar) pressure minimum.
2. Apply the brakes. Inspect the brake action on all the wheels for proper application.
3. Release the brakes. The brakes must release promptly. Air pressure must discharge quickly from the relay emergency valve.
4. Disconnect the emergency line from the trailer. The trailer brakes must automatically apply.
5. Connect the emergency line. The brakes must release.

Air Reservoir

Drain condensation from the reservoir while the reservoir is pressurized. Cables for the drain valves are located on the roadside of the trailer frame. Listen for leaks after releasing the drain valve cables.

Air Hoses and Tubing

Air hoses and tubing must be checked for chafing, bends and kinking. Replace faulty parts.

Brake Relay Emergency Valve

The air system tests may disclose a malfunction of the relay emergency valve. Repair or replace faulty units. Contact an authorized representative of the original equipment manufacturer for relay valve servicing.

Air Brake Chambers

The air system tests should disclose any malfunctioning brake chambers. Repair or replace faulty units. The diaphragm and any worn parts must be replaced.

When replacing the diaphragm or the spring, replace the corresponding parts for the other chamber on the same axle to aid in even brake application and release. Examine the yoke pin for wear and replace it if necessary.

Brake Air Supply System Description

(see Figure 21)

The trailer relies on the tractor for its air supply. A description of the system operation follows:

1. When the service and emergency lines are connected to the towing vehicle, the reservoir is charged to approximately the same pressure as is present in the tractor reservoir. The relay emergency valve will keep the trailer brakes applied until the emergency line pressure reaches 60 PSI (4.14 Bar). The brakes will then be released.

2. When the towing vehicle and the trailer are traveling over the road, the brakes are released and the emergency line and reservoir are charged to full pressure.

3. When the service brakes are applied in the towing vehicle, the pressure is increased in the service line. This fills the brake chambers with the same pressure as the service line and applies the trailer brakes.

4. Releasing the service brakes will cause the pressure in the service line to decrease, causing the relay emergency valve to exhaust the pressure from the brake chambers.

5. The trailer brakes can also be applied independently from the tractor brakes by actuating a hand controller. This supplies air pressure to the service line.

6. The brakes will also apply if the pressure in the emergency line is reduced to about 30 PSI (2.07 Bar). A gradual decrease in the emergency line pressure will cause a gradual increase in the pressure to the brake chambers.

7. A sudden release of pressure in the emergency line

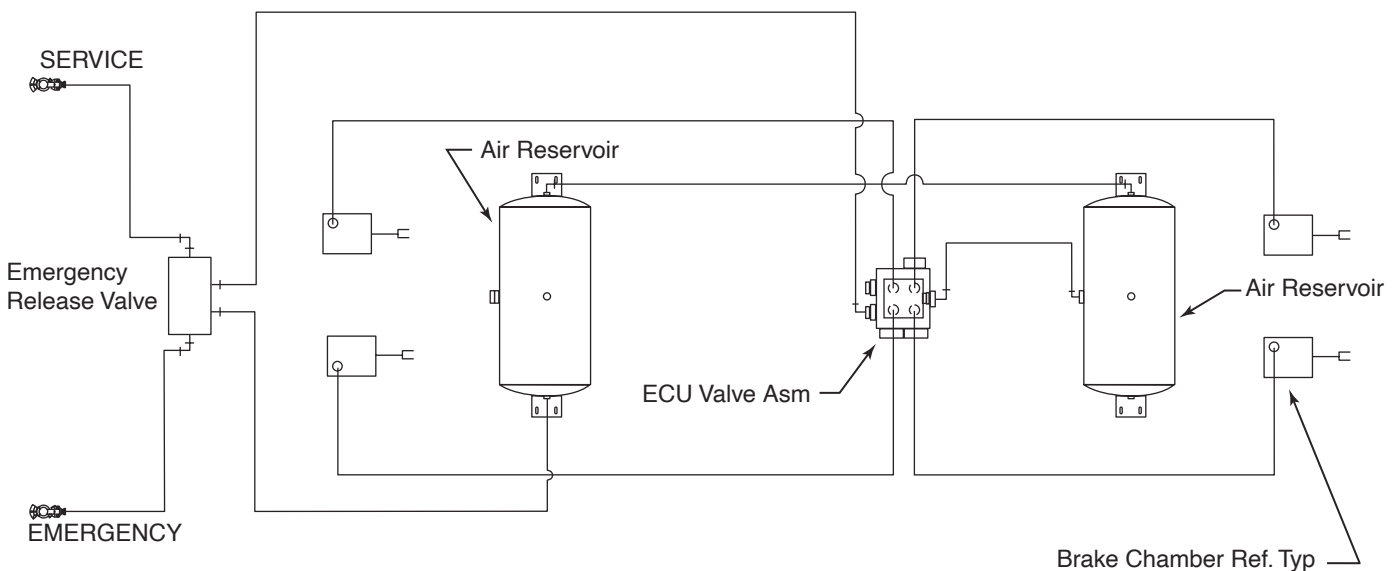

Figure 21. Brake Air Supply System - 2 Axle Shown

will cause a full release of reservoir pressure into the brake chambers, resulting in full brake application.

Relay Emergency Valve

(see Figure 22)

The relay emergency valve senses the line pressures and relays the response to the brake chambers. Daily operating tests are described elsewhere in this manual. Before conducting further tests, check the tractor air pressure gauge against an accurate test gauge.

1. Connect the service and emergency lines. When the pressure reaches 60 -65 PSI (4.14 - 4.48 Bar), the brakes must automatically release.
2. Apply and release the service brake several times. Check for prompt brake application and release.

WARNING
<p style="text-align: center;">Block the wheels during these tests.</p>

3. Release the brakes and stop the engine with the system pressure between 90 - 100 PSI (6.2 -6.9 Bar). A two minute check must show a pressure drop of no more than 6 PSI (0.41 Bar) for the combination vehicle system.

4. If step "3" indicates possible leakage, apply soap suds at the relay emergency valve exhaust port. A one inch (25.4 mm) soap bubble in not less than five seconds is permissible.

5. Apply soap suds at the pipe plugs and fittings. Correct all leaks as indicated.

6. With the engine stopped and the pressure at 90 - 100 PSI (6.2 - 6.9 Bar) make and hold a full service brake application. A two minute check must show a pressure drop of no more than 8 PSI (0.55 Bar) for the combination vehicle system.

7. If Step "6" indicates possible leakage, apply soap suds on the relay emergency valve cover and exhaust port. A one inch (25.4 mm) bubble in not less than three seconds is permissible. Correct all leaks as indicated.

8. Place the tractor protection control valve in "emergency" position or close the cutoff valve on the emergency line. Disconnect the emergency line coupling. The trailer brakes must apply promptly.

Check for leakage at the emergency coupling. A leak indicates a leaking check valve or O-rings in the relay emergency valve. Also check the service line. A leak here indicates leaking O-rings in the relay emergency valve. Recharge the system. The brakes must release at 65 PSI (4.48 Bar) emergency line pressure.

9. Stop the engine with the system fully charged. Make a series of foot valve applications. Reduce the pressure to 30 PSI (2.07 Bar). The trailer brakes must apply automatically at this pressure or at the emergency setting the tractor protection equipment.

If the valve does not function properly or leakage excessive, it must be repaired or replaced.

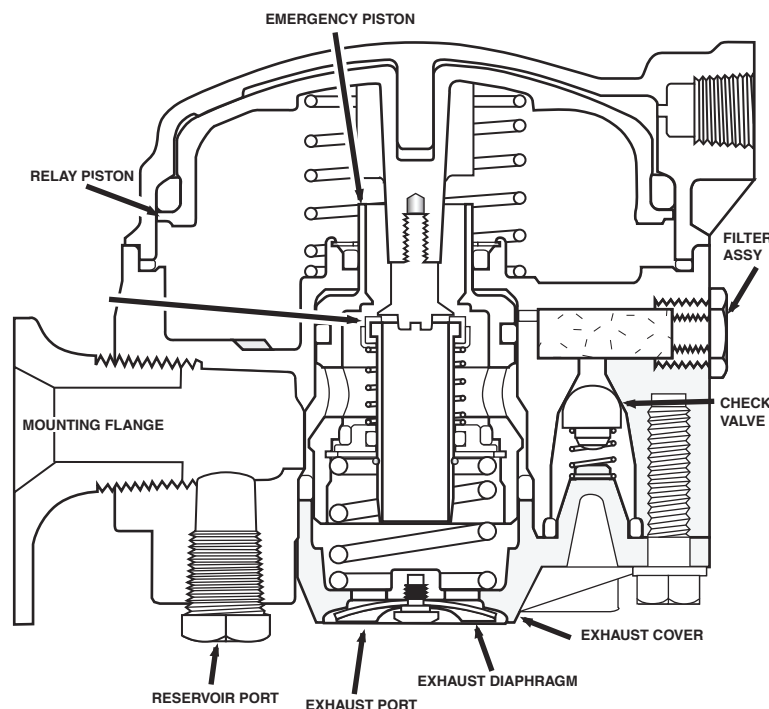

Figure 22. Relay Emergency Valve

Brake Chambers

(see Figure 23)

Air pressure on the pressure plate side of the brake chamber diaphragm pushes the diaphragm against the push rod assembly. This extension of the push rod pushes against the slack adjuster, which actuates the brakes.

Brake Chamber Servicing

If an air leak is detected around the clamp ring, the bolts can be tightened to stop the leak.

⚠ CAUTION

Overtightening the bolts can cause permanent distortion of the clamp ring. Do Not exceed a torque of 130 inch lbs. (14.7 N.M..)

Brake Chamber Removal

Disconnect the air line and the push rod yoke. Remove the nuts from the mounting studs. Remove the air chamber.

Brake Chamber Disassembly

1. Clean the exterior of the brake chamber.
2. Put a mark on the parts so they can be reassembled in the same relative positions.
3. Pull out the push rod and clamp the push rod in the extended position with vise grip pliers.

NOTE: Tape the grips to prevent damage to the push rod.

4. Remove the bolts from the clamp ring.
5. Spread the clamp ring and remove it.

⚠ CAUTION

Use care not to bend the clamp ring out of shape.

6. Remove the pressure plate and diaphragm.
7. Remove the locknut and the yoke from the push rod.
8. Release the grip on the push rod.
9. Remove the push rod and the spring.

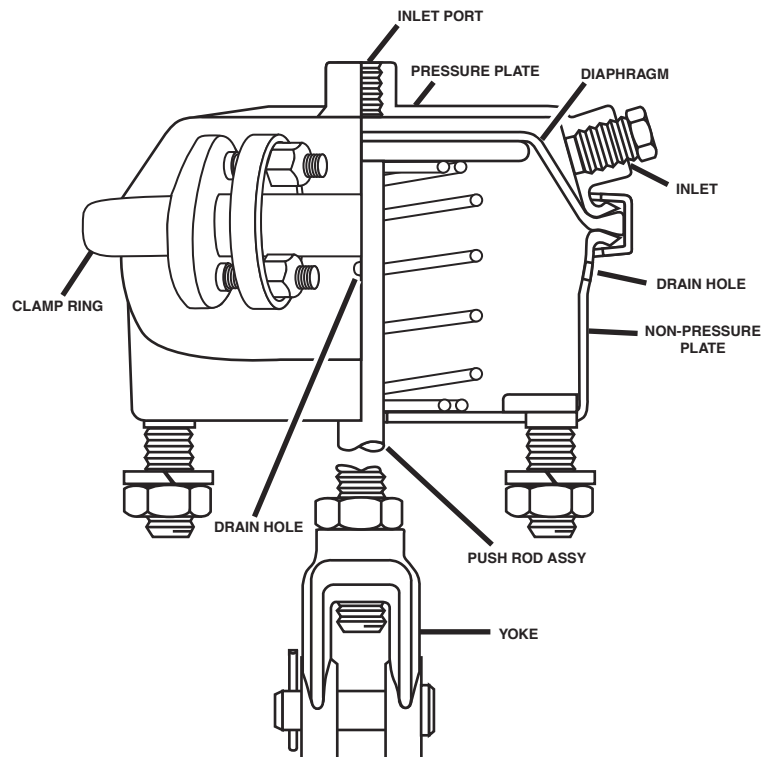

Figure 23. Brake Chamber

Cleaning and Inspection of Parts

Clean the metal parts in a solvent. Inspect all the parts for damage, wear or deterioration and replace defective parts.

Brake Chamber Assembly

1. Stand the push rod assembly on a flat surface.
2. Put the return spring in position.
3. Place the non-pressure plate over the push rod.
4. Push the non-pressure plate down against the flat surface. Hold it in place with vise grip pliers clamped to the push rod.

NOTE: Tape the grips to prevent damage to the push rod.

5. Place the clamp ring over the non-pressure plate clamping surface.

6. Position the diaphragm in the pressure plate. Assemble it with the non-pressure plate by working the clamp ring over the pressure plate. Align all the marks made during disassembly.

7. Draw the clamp lugs together. Start the clamp bolts and nuts. Tighten the nuts to a maximum torque of 130 inch lbs. (14.7 N.M.)

 **CAUTION**

Overtightening the bolts can cause permanent distortion of the clamp ring.

Installation

Place the brake chamber in the mounting bracket and tighten the nuts on the studs. The drain hole must be placed in the down position. Install the yoke and the locknut on the push rod. Connect the push rod to the slack adjuster with the yoke pin. Adjust the brakes. Check the angle formed by the slack adjuster and the push rod with the brakes applied. This angle must not be less than 90° with the brakes adjusted. Turn the yoke to obtain this angle. The angle must be the same for all slack adjusters to obtain equal braking force at all wheels.

Trailer ABS

Meritor WABCO ABS is an electronic system that monitors and controls wheel speed during braking. The

system works with standard air brake systems.

ABS monitors wheel speed at all times and controls braking during wheel lock situations. The system improves vehicle stability and control by reducing wheel lock during braking.

The ECU receives and processes signals from the wheel speed sensors. When the ECU detects a wheel lockup, the unit activates the appropriate modulator valve, and the air pressure is controlled.

In the event of a malfunction in the system, the ABS in the affected wheel(s) is disabled; that wheel still has normal brakes. The other wheels keep the ABS function.

An ABS warning light lets drivers know the status of the system.

For a complete description of diagnostic and maintenance procedures refer to Meritor WABCO Maintenance Manual no. 33.

Air Brakes

General

Etnyre trailers are equipped with cam actuated brakes. Braking force is supplied by air pressure in the brake chamber, which pushes a push rod against the end of the slack adjuster. The slack adjuster rotates the camshaft, which forces the brake shoes against the brake drum.

Operating Checks

- Periodically check the brake drums for heating.
- A cool brake drum may indicate an inoperative brake.

 **WARNING**

Proceed cautiously. Malfunctioning or misaligned brakes can cause the drum to become extremely hot. Do not operate the vehicle until the problem causing the overheating is corrected.

Brake Assembly

Examine the brake linings visually to locate the lining showing the greatest amount of wear.

CAUTION

Do Not allow the linings to wear thin enough so the lining bolts or rivets contact the drum.

Grease the anchor pins, camshaft bracket bearing and the spider busing at four (4) grease fittings. Do Not use an excessive amount of grease on the anchor pins and spider bushing. Avoid getting grease on the brake lining surfaces. (See Figure 24)

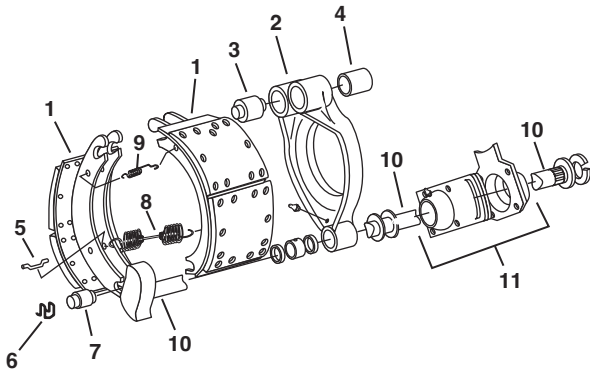

Figure 24. Brake Components

- 1. Shoe/Lining
- 2. Spider Assembly
- 3. Anchor Pin
- 4. Bushing
- 5. Pin
- 6. Retainer
- 7. Roller Cam
- 8. Retract Spring
- 9. Retention Spring
- 10. Brake Assembly- LH & RH
- 11. (unlabeled)

Slack Adjuster

Gunite Automatic Slack Adjuster

**Recommended Preventative Maintenance
Every Three Months or 25,000 Miles**

1. Check the condition of the foundation brakes, including drums, shoes and linings, cams, rollers, bearings, etc.
2. Check for structural damage of the automatic slack adjuster housing and condition of the boot for cuts, tears, etc. Replace if necessary.
3. After allowing brake drum to cool to room temperature, check for correct chamber stroke. See chart below for recommended stroke measurements.

Chamber Type	Maximum Stroke
12	less than 1-3/8"
16	less than 1-3/4"
20	less than 1-3/4"
24	less than 1-3/4"
30	less than 2"

Every Six Months or 50,000 Miles

The Gunite automatic slack adjusters are factory lubricated and extensively sealed to protect against dirt, water, salt and other corrosive elements. Nevertheless, periodic lubrication is recommended. (See Figure 30)

1. Grease the automatic slack adjuster.

(a) The styles of grease plugs or reliefs vary according to models.

(b) If your model has a grease plug, remove it from cap opposite hex extension.

NOTE: Failure to remove grease plug could result in boot and/or seal damage.

(c) A grease fitting is provided to allow fresh lubrication during normal chassis servicing. With a conventional grease gun and an approved grease, fill the inside of the slack until grease flows from the grease plug hole or automatic grease relief.

(d) **Lubriplate Aero** is an approved grease and is used in the manufacture of Gunite automatic slack adjusters. It is recommended for use in temperatures as low as -40° F. Texaco Multifak EP-2 and Mobil Grease #77 are also approved greases, but are not recommended for use in temperatures below -20° F.

(e) Install the grease plug if your model has one, and tighten to 70 - 90 in.-lbs. torque.

2. Test adjuster function.

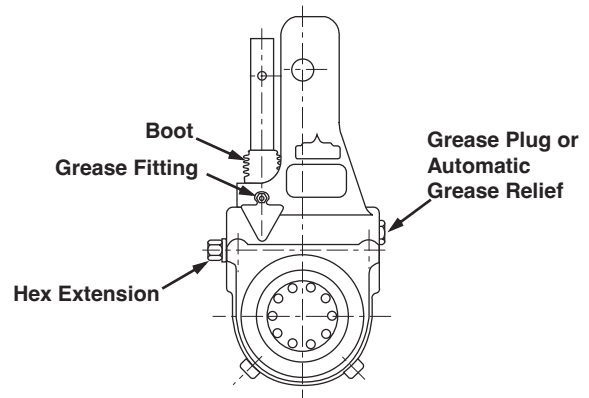

Figure 25. Lubrication Point- Slack Adjuster

Testing Adjuster Function

If maximum stroke at 85 psi of the Gunite automatic slack adjuster is less than the distance in the **Maximum Stroke Chart** below, the adjuster is functioning properly.

MAINTENANCE

Chamber Type	Maximum Stroke
12	less than 1-3/8"
16	less than 1-3/4"
20	less than 1-3/4"
24	less than 1-3/4"
30	less than 2"

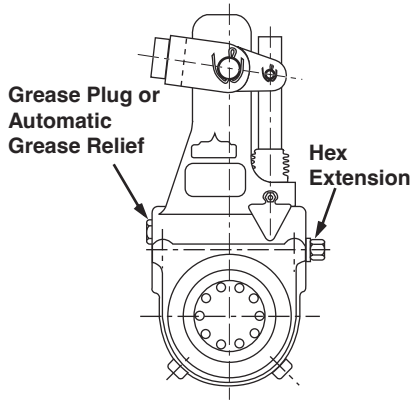

Figure 26. Adjuster Function

1. The Gunite Automatic Slack Adjuster should not require manual readjustment. If the maximum chamber stroke is within the range for the size chamber used (see figure 4-25), the slack should not be manually readjusted. If the chamber stroke exceeds the limit, turn the hex extension 1/2 turn **counterclockwise**. Apply the brakes several times and watch for the hex to rotate **clockwise**. A box wrench on the hex makes an excellent indicator to magnify the movement. The hex extension must rotate **clockwise**. The adjustment is intentionally made in small increments so it will take several cycles to bring the adjuster within the stroke limit shown in the chart.

2. Check the torque by attaching a torque wrench to the hex extension and turning it in a **counterclockwise** direction and record the measurement.

3. If the hex extension did not rotate clockwise or there is less than 15 ft.-lbs. of torque in the counterclockwise direction, the automatic slack must be replaced. If immediate replacement is not possible, proper brake adjustment must be maintained by manual adjustment.

4. If the hex extension rotates clockwise and has a counterclockwise torque of greater than 15 ft.-lbs., the slack is functioning properly. Check the foundation brake for proper function, worn cam bushings, pins and rollers or broken springs. Repair as necessary and repeat the test.

5. Readjust the brake after the Function Test.

Boot Replacement

(See Figures 32, 33 and 34)

1. Remove the 1/4" and 1/2" clevis pins.
2. Rotate the hex extension counterclockwise to clear the link from the clevis. This will require up to 45 ft.-lbs. of torque and produce a clicking noise. Only the link needs to be cleared which requires about one revolution of the hex extension.
3. Remove the damaged boot from the link.
4. Install the replacement boot over the link with the heavy section down. Care should be taken not to damage the boot with a sharp tool.
5. Position the boot on the link so that the bottom is retained by the boot insert and the top is positioned by the groove in the link.
6. Install the clevis pins.
7. Check the torque as detailed under "Testing Adjuster Function".

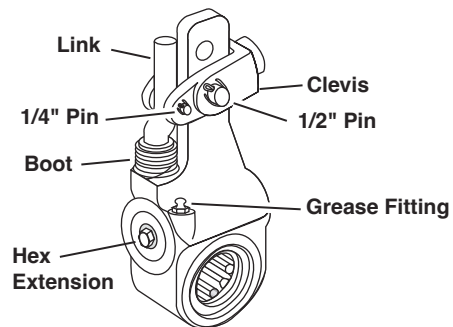

Figure 27. Location of Clevis Pins, Hex Extension and Boot

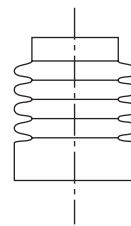

Figure 28. Boot

⚠ CAUTION

Check the brake adjustment frequently during the first 500 miles after relining. Overloading or using only the trailer brakes to stop the complete tractor-trailer unit will cause the heat absorption capacity of the brake to be exceeded. Hotter brake linings and drums, longer stopping distances, and shorter brake lining life will result.

Trouble Analysis for Air Brakes

Trouble	Probable Cause	Corrective Action
No brakes or intermittent brakes.	Brake air system improperly connected. Relay emergency valve contains water or oil. Tractor protection valve malfunction. Restricted tubing or hose line. No air pressure due to: a. Broken line. b. Failure in tractor air supply.	Reconnect correctly. Clean valve. Repair or replace valve. Locate and remove restriction. Locate leak and repair. Troubleshoot tractor air system.
Single brake dragging or locked.	Broken component within brakes: a. Retract spring. b. Cam roller. c. Shoe. d. Lining fasteners. e. Anchor pin. f. Spider. Flat spot on cam roller or camshaft Improper adjustment. Spider bushing or cam bracket bushing binding. Improper Lubrication Worn anchor pin bushing. Brake drum distortion. Broken brake chamber spring. Brake chamber pushrod binding.	Replace broken part. Replace defective parts. DO NOT lubricate mating surfaces of cam or cam roller. Adjust slack adjusters. Lubricate or replace bushing. Lubricate Replace bushing. Repair or replace drum. Replace spring. Realign brake chamber bracket or install correct brake chamber.

(continued)

Trouble Analysis for Brakes (continued)

Trouble	Probable Cause	Corrective Action
Uneven brakes.	<i>See "Single brake dragging or locked" in this section.</i>	
	Restriction in brake hoses.	Locate and remove restriction.
	Leaking brake chamber diaphragm.	Replace diaphragm.
	Linings worn out.	Reline brakes.
	Grease on linings.	Reline brakes.
Brakes apply too slowly	Broken slack adjuster.	Replace slack adjuster.
	Brakes need adjustment or lubrication	Adjust and lubricate brakes.
	Low air pressure in brake system	Check tractor air system (below 80 PSI) (5.5 Bar)
	Restricted tubing or hose.	Locate and remove restriction.
	Defective relay emergency valve.	Clean and repair or replace valve
Brakes release too slowly.	Brakes need adjustment or lubrication.	Adjust and lubricate brakes.
	Brake components binding.	Align brackets or replace bent components.
	Exhaust port or relay emergency valve restricted or plugged.	Clean valve.
All brakes do not release	Brake air system improperly connected	Reconnect correctly.
	Brake valve on towing vehicle applied.	Release brake.
	Relay emergency valve in emergency	Check line pressure and valve position.
	Restriction in brake hoses.	Locate and remove restriction.
	Tractor protection valve malfunction.	Troubleshoot tractor air system.

(continued)

Trouble Analysis for Brakes (continued)

Trouble	Probable Cause	Corrective Action
Insufficient brakes.	Brakes need adjustment. Brakes need lubrication. Lining worn away. Defective relay emergency valve. Brakes overheated. Low air pressure.	Adjust brakes. Lubricate brakes. Reline brakes. Repair or replace valve. Stop and allow to cool. Locate the cause of overheating. Troubleshoot tractor air system.
Brakes grabbing.	Lubricant on brake lining. Brake components binding. Defective brake valve on towing vehicle. Defective relay emergency valve.	Reline brake. Locate cause and repair, adjust or replace components. Repair or replace valve. Repair or replace valve.
Excessive leakage with brakes released.	Relay emergency valve leaking. Leaking tubing or hose line.	Repair or replace valve. Tighten or replace leaking lines.
Excessive leakage with brakes applied.	Relay emergency valve leaking. Leaking brake chamber or diaphragm. Leaking tubing or hose line.	Repair or replace valve. Tighten clamp ring or replace diaphragm. Tighten or replace leaking lines.
Excessive leakage with emergency system only applied - no leakage with normal brake application.	Defective relay emergency valve.	Clean and repair, or replace valve.
Excessive water present in Reservoir brake system.	Reservoir not drained often enough.	Drain reservoir daily.
Excessive oil present in brake system.	Compressor on towing vehicle passing excessive oil.	Repair compressor.
Brake will not apply.	Flat spot on cam roller or camshaft.	Replace defective parts.

Electrical

Lighting System

Etnyre trailer light wiring is color coded per SAE specifications. The standard trailer lighting system operates on 12 volt current. If the tractor electrical system provides other than 12 volts, the trailer light bulbs must be changed to match the tractor system voltage.

For SR model trailers with optional self-contained hydraulic system: See the engine manual supplied with your trailer for troubleshooting the engine electrical system for the self-contained hydraulic system.

Ground white terminal to a convenient place on the truck frame. This gives a dependable ground to the trailer lights without grounding through fifth wheel.

Code	Color	Use (circuit)
W	White	Ground
BK	Black	Identification Lights
Y	Yellow	Left Turn Signal
R	Red	Stop Lights
G	Green	Right Turn Signal
BR	Brown	Tail & License Plate Lights

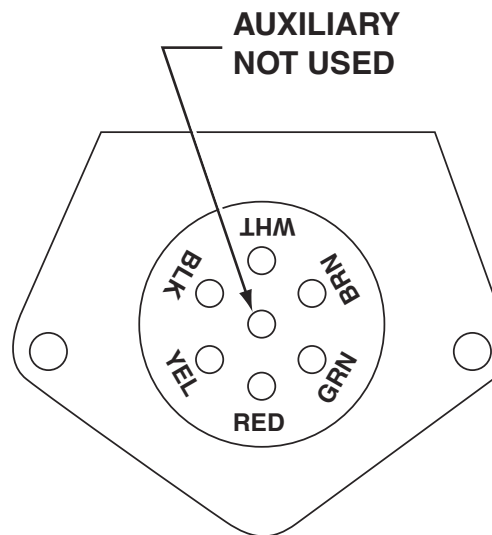

Figure 32. Gooseneck Socket Connection

Trouble Analysis for Hydraulic Systems		
Trouble	Probable Cause	Corrective Action
Hydraulic system operates slowly or trailer will not lift capacity load.	Piston seals leaking, allowing oil to bypass.	Repack piston
	Pressure relief valve incorrectly adjusted or broken.	Adjust valve or replace defective parts.
	External leak on cylinder head.	Repack head.
	External leak at fittings.	Remove and reseal or replace fittings.
	Defective control valve.	Repair or replace valve.
	Overload on trailer.	Do not exceed capacity of trailer.
	Hydraulic oil cold.	Cycle oil to raise temperature and improve oil flow.
Excessive hydraulic system noise.	Air cavitating the system due to:	
	a. Low oil level.	Fill system.
	b. Suction line leaks air (foam present in tank).	Replace defective parts. Seal and tighten leaking fittings.
	c. Incorrect hydraulic filter.	Replace with Etnyre approved filter.



Something Wrong with this manual?

If you find inaccurate or confusing information in this manual, or just have a suggestion for improvement, please let us know.

Mail or FAX this form to us at: E. D. ETNYRE & CO. 1333 S. Daysville Rd. Oregon, Illinois 61061 • Fax: 800-521-1107 • www.etnyre.com
Attn: Service Manager

Recommended changes from: _____

Address _____

City, State, Zip _____

Phone _____

Date Sent _____

Manual Number (upper right corner of front cover) _____

Manual Title _____

Explain the problem in the space below.

Page Number	Reference Number	Paragraph Number	Figure Number	Problem (please be specific)