

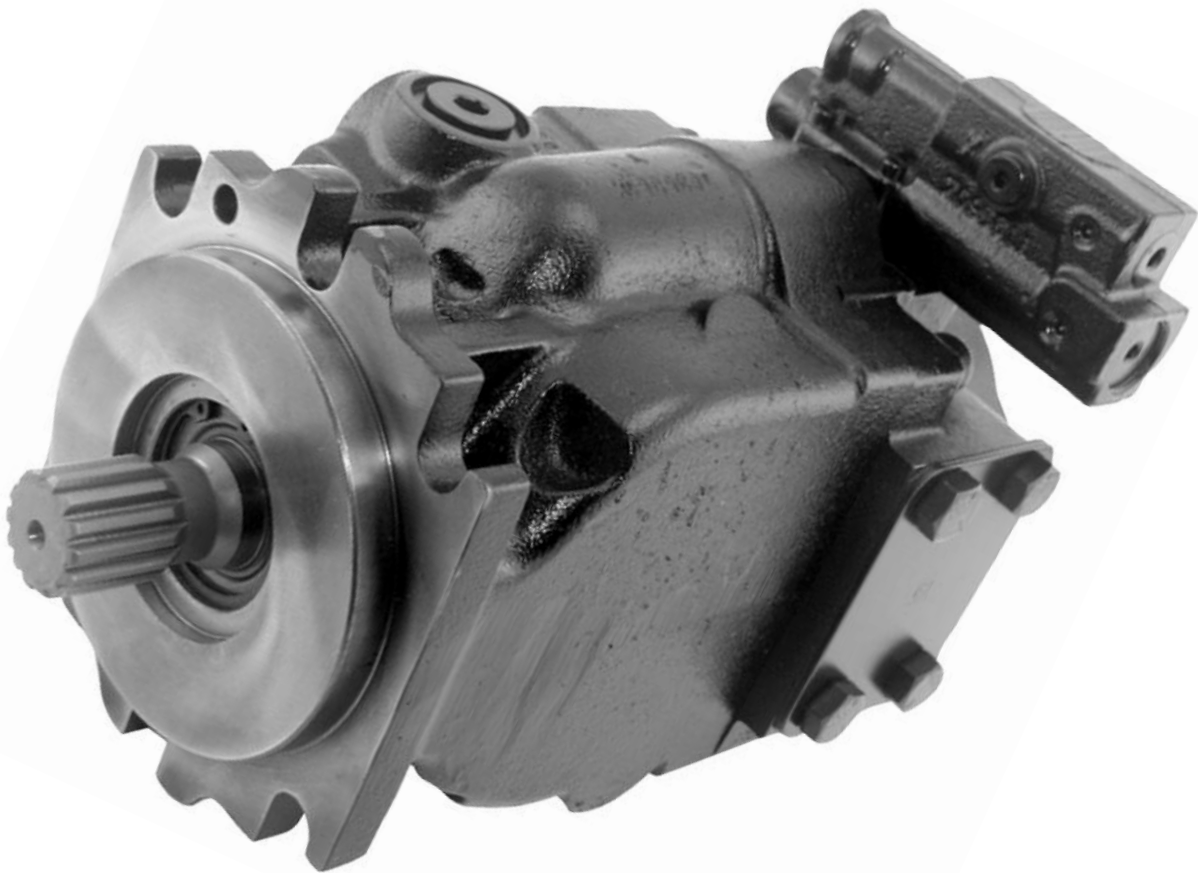

## Service Manual Sauer-Danfoss J Frame LS Pump



Etnyre International

[www.etnyre.com](http://www.etnyre.com)

1333 S. Daysville Road, Oregon, IL 61061 USA

Ph: (815) 732-2116

## Cautions and Warnings

Always read all instructions thoroughly and familiarize yourself with the equipment before operating or attempting repairs or service.

Observe all caution and warning statements in the applicable manual and on the equipment.

Always use extreme caution when working with any pressurized system. Always be aware of other persons and/or equipment in the immediate area and the hazards involved. Be prepared to immediately shut down the truck and/or hydraulic system if required, especially during initial startup and testing.

The equipment must be assembled and serviced by a trained mechanic or technician. Ensure only properly trained individuals should operate the equipment.

Always use personal protection equipment, such as eye and ear protection, when indicated by the instructions or by the work environment.

Always operate equipment safely and within its rated capacity and performance range. Hydraulic fluid in the human bloodstream can be fatal. If hydraulic fluid penetrates the skin under pressure, seek medical attention immediately! Hydraulic oil, solvents, and pipe sealers may cause skin irritation and rashes. Avoid lengthy exposure to these materials. Wash your hands thoroughly after contact with oils, solvents, and other chemicals. Remove clothing that is saturated with oil.

Do not operate equipment that is damaged or in need of maintenance. Repair equipment as soon as problems are identified.

Use tools that are suited to the task, and keep your tools in good repair.

Use proper lifting equipment when moving or installing heavy components.

Keep your work area clean and safe. Always clean up any spills immediately and properly dispose of the material in the designated refuse container.

Always shut off the vehicle engine and disconnect pump electrical power before working on the hydraulic system.

Etnyre International is not responsible or liable for injury, damage, or loss caused by improper installation by the end user, misuse of the equipment, lack of maintenance, accidents, or failure to follow instructions. In cases where equipment application was determined by the end user, Etnyre International is not responsible or liable for injury, damage, or loss caused by misapplication of this equipment.

Specifications, parts descriptions, illustrations, and instructions in this manual were accurate at the time of publication. Etnyre International reserves the right to discontinue products and to change specifications and/or designs at any time without notice and without incurring any obligation.

**TABLE OF CONTENTS**

**Safety Disclaimer**

**Table of Contents**

**Section 1 - Pump over view**

**Section 2 - Color schematic of typical circuit**

**Section 3 - Dimensional Drawing**

**Section 4 - Adjusting the Control Settings**

**Section 5 - Isolating the Pump Schematic**

**Section 6 - Hydraulic Pump Commissioning Instructions**

**Section 7 - Pressure Setting Guide**

SECTION 1

Sauer-Danfoss Series 45 open circuit piston pumps are axial piston, swash plate design, variable displacement pumps. As illustrated by the picture under functional purposes they basically consist of a housing, control pistons located inside the cylinder barrel, drive shaft, swash plate, a control valve assembly and pistons. This piston pump smoothly and continuously varies its displacement by altering the angle of the swash plate. As the system operated, valves monitor the load pressures on the Road-Saver's systems and control the swash plate accordingly. The greater the angle of the swash plate, relative to the drive shaft, the further the pistons stroke in and out creating greater fluid flow.

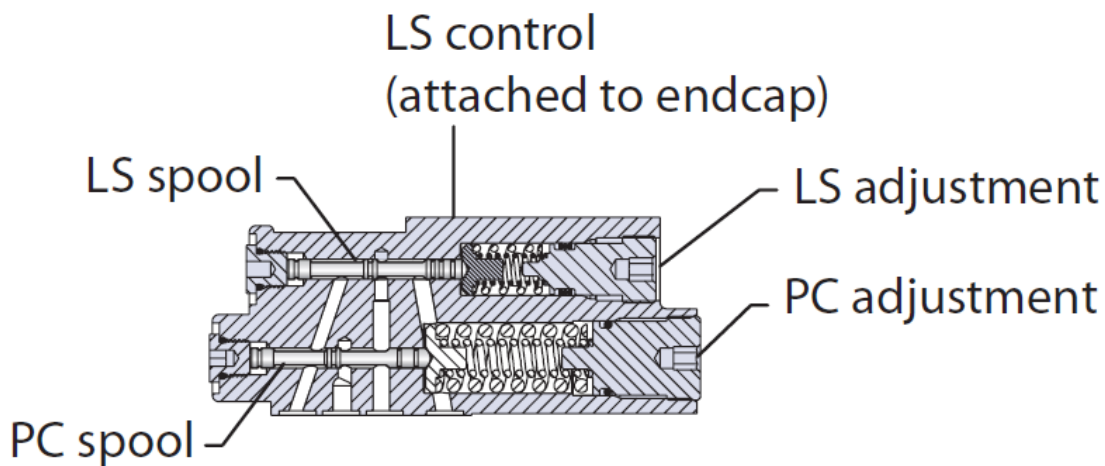
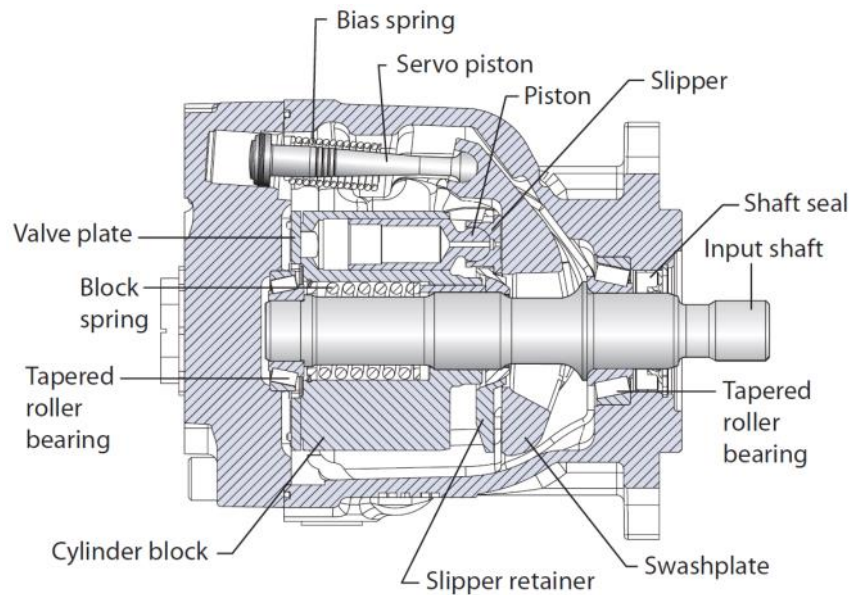

The LS control design matches pump flow with system demand. The LS control senses the flow demand of the system as a pressure drop across the External Control Valve (ECV). As the ECV opens and closes, the pressure delta across the valve changes. When opening, the delta decreases. When closing, the delta increases. The LS control then increases or decreases pump flow to the system until the pressure delta becomes equal to the LS setting as defined by the LS adjusting plug (7) and spring (8).

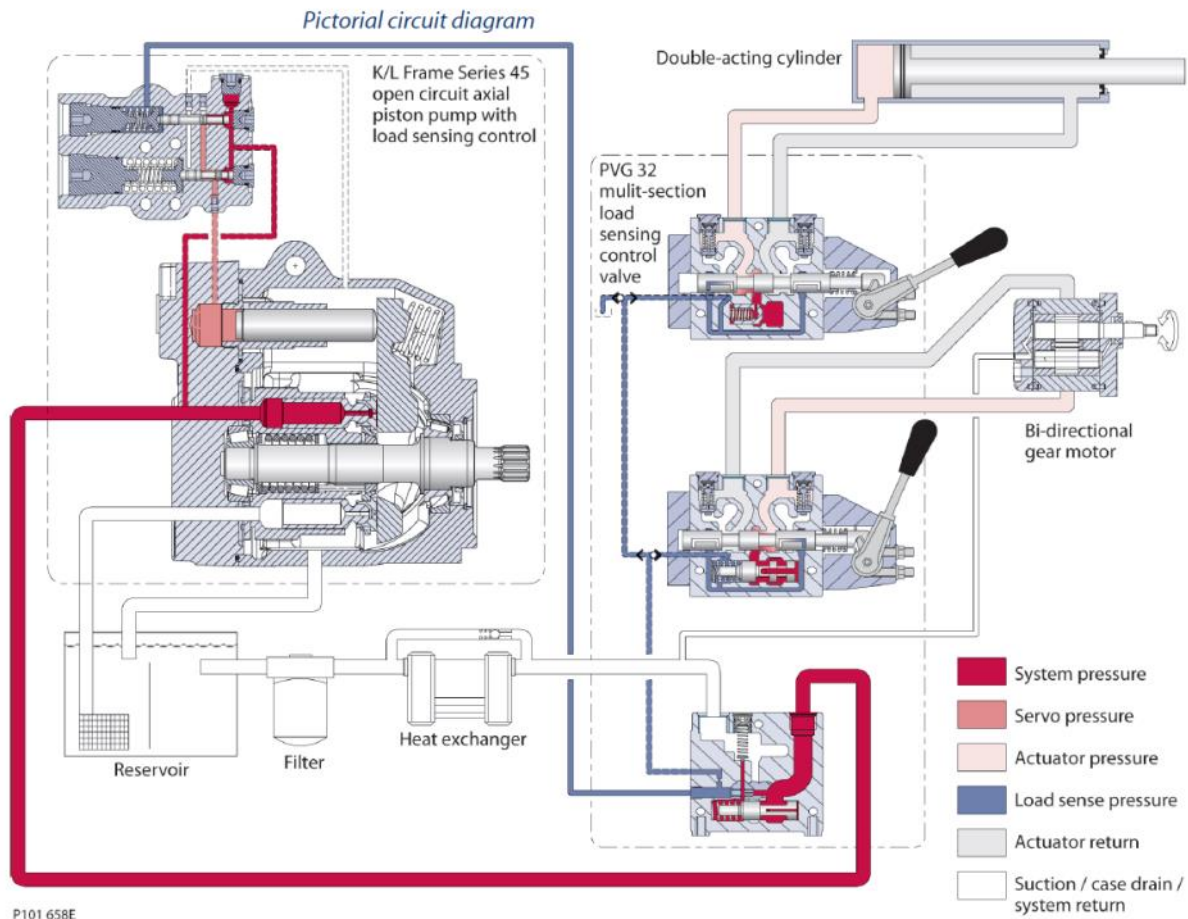

The pump receives fluid directly from the reservoir through the inlet line. A screen in the RoadSaver suction line protects the pump from large contaminants. The pump outlet feeds directional control valves or cartridge valves. The valves direct pump flow to cylinders, motors and other RoadSaver functions. A filter cleans the fluid before it returns to the reservoir.

Flow in the circuit determines the speed of the actuators. In the instance of a proportional valve the valve determines the flow demand. A hydraulic pressure signal (LS signal) communicates demand to the pump control. The pump control monitors the pressure differential between pump outlet and the LS signal, and regulates servo pressure to control the swashplate angle. Swashplate angle determines pump flow.

Work load determines system pressure. The pump control monitors system pressure and will decrease the swashplate angle to reduce flow if system pressure reaches the PC setting.

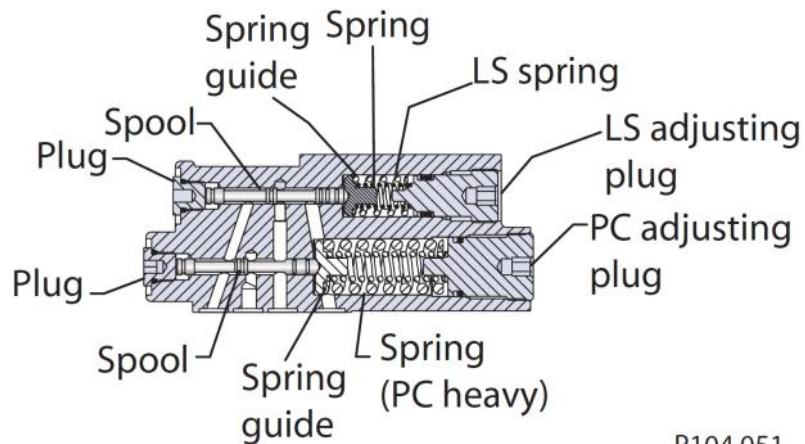
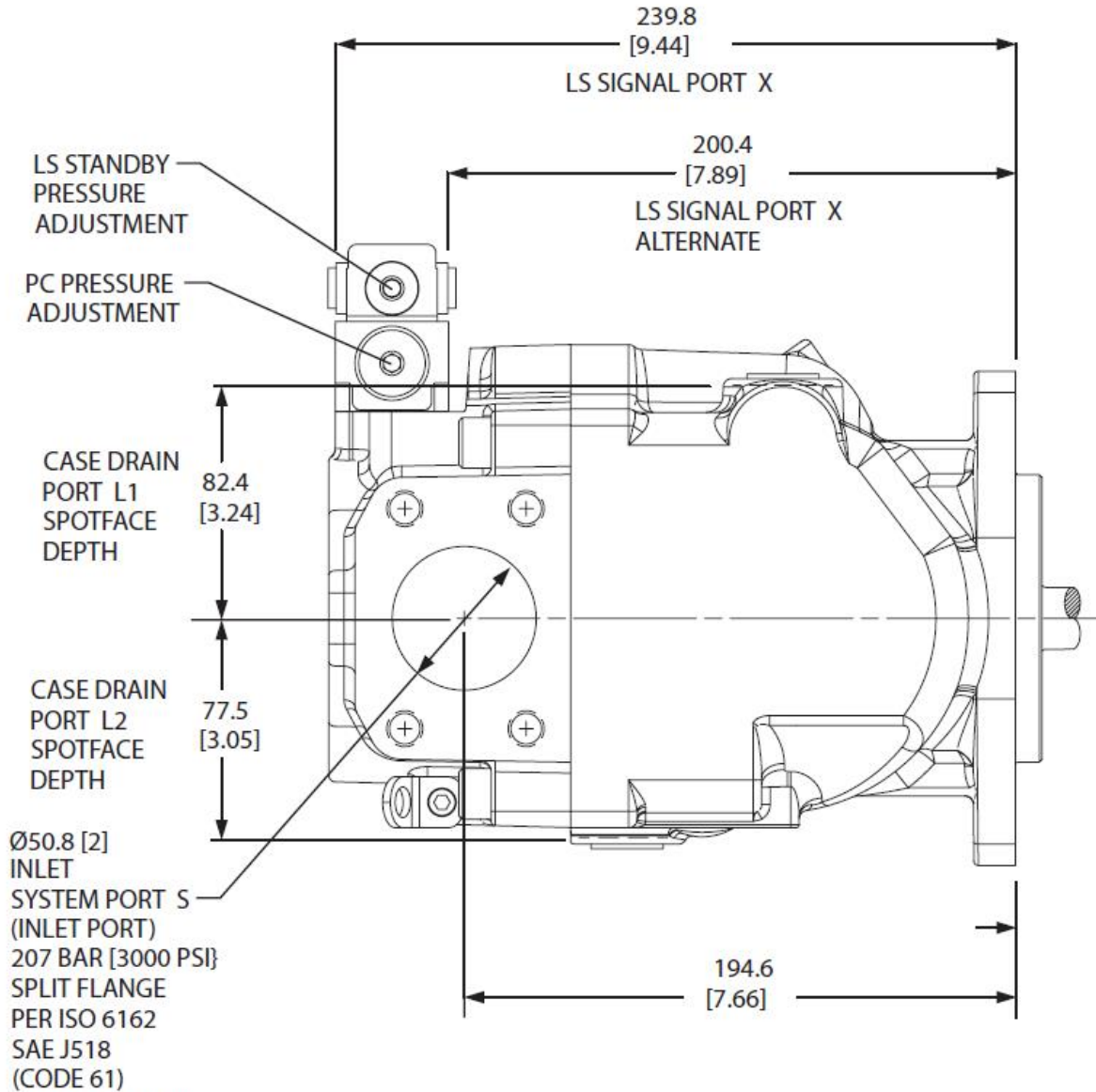

P104 051

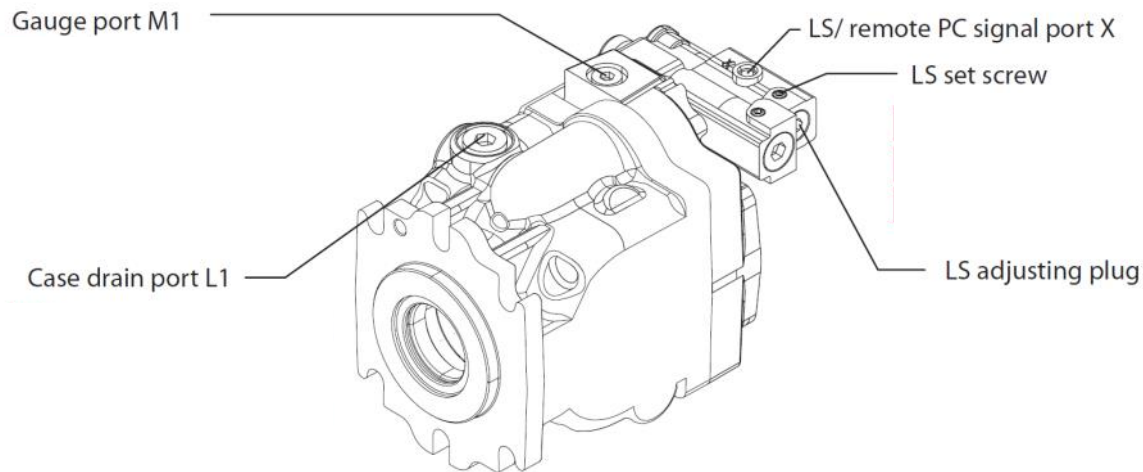

## Setting the compensator and load sense pressure settings

The pressure settings can be set without isolating the pump however the settings will be influenced by downstream leakage, etc. Isolating the pumps pressure port will provide clear proof of actual pump performance. Refer to page 8 for the isolation schematic.

Before performing adjustments, read safety disclaimer.

- 1) Install a pressure gauge in port M1 to measure system pressure. Tee-in a gauge to the LS/remote PC signal line (port X).
- 2) Start the engine and allow fluid to reach normal operating temperature.
- 3) Loosen the LS set screw. While watching the pressure gauges, turn the LS adjusting plug until 400 PSI is achieved. Clockwise rotation increases the setting, counterclockwise rotation will decrease it; approximate gain = 17 bar [250 psi] per turn. **(The LS setting should be 27 bar or 400 PSI.)**
- 4) While holding the position of the LS adjusting plug, torque the LS set screw to 7.5 - 10.8 N•m [5.5-8 lbf•ft].
- 5) Operate a hydraulic function to its full extension loading the pump at maximum pressure and zero flow.
- 6) Loosen the PC set screw and turn the PC adjusting plug until the desired setting is indicated on the pressure gauge at port M12. Clockwise rotation increases pressure, counterclockwise rotation decreases it; approximate gain = 42 bar [610 psi] per turn.
- 7) While holding the position of the PC adjusting plug, torque the PC set screw to 7.5 - 10.8 N•m [5.5-8 lbf•ft].
- 8) Stop the engine, remove the pressure gauges, and return the system to its normal operating configuration.

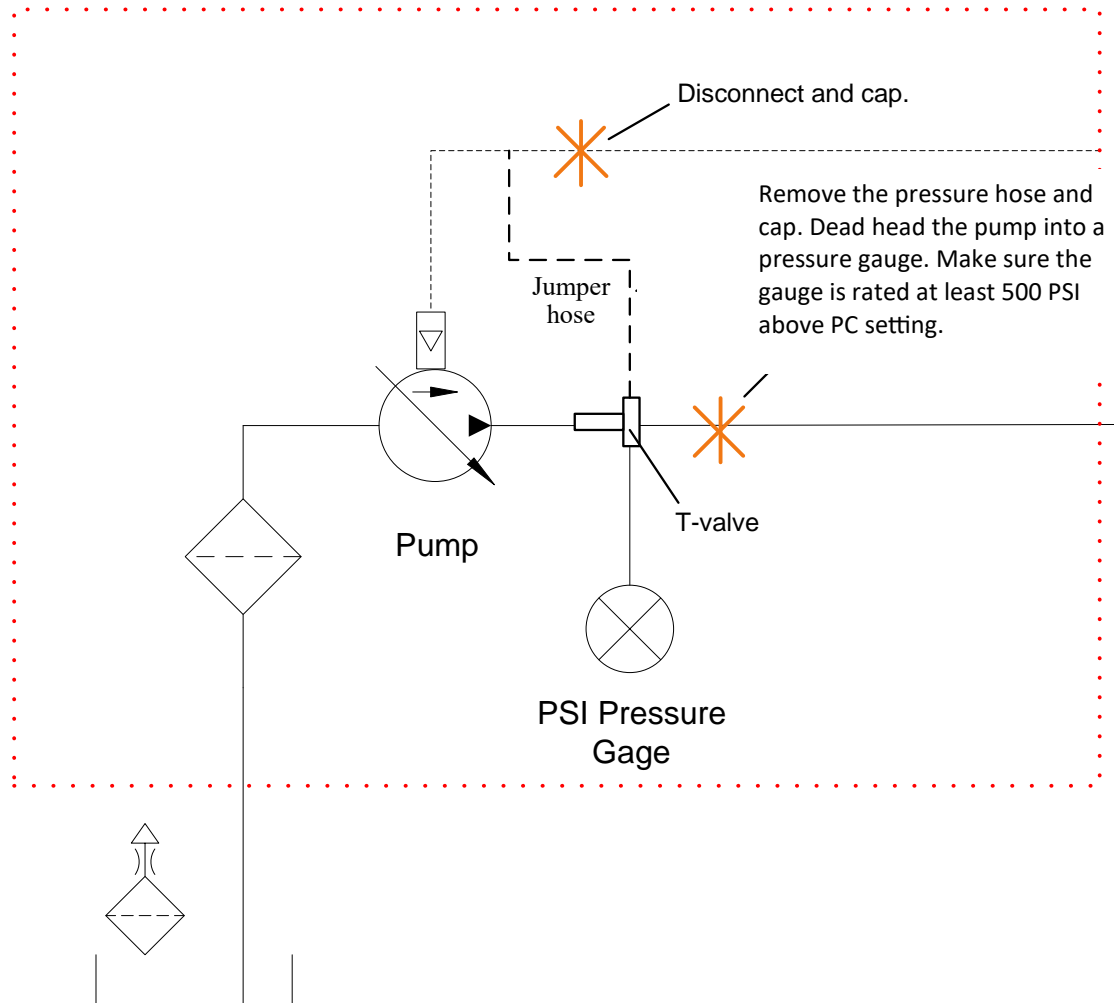

### Isolate the pump from the system by:

1. Disconnecting the pressure line
2. Install high pressure plug in the hose to prevent any loss of hydraulic oil.
3. Connect the test fitting and gauge as shown above.

*The purpose of this test is to isolate the pump and set the pressures independent of any down stream influence. This will ensure the settings are not corrupted by any fluid loss in other components.*



**HYDRAULIC PUMP COMMISSIONING INSTRUCTIONS**

- 1) After reinstalling on the RoadSaver ensure all fittings, hoses and components are flushed clean and free of grit and dirt.
1. Fill the hydraulic oil reservoir and pump through a filter to avoid adding contamination to the hydraulic system. **Only use ISO 68 hydraulic fluid.** Always filter fluid through a 10 micron filter pouring into the reservoir. Never reuse hydraulic fluid.

**IMPORTANT NOTE:** Fill the pump case to the highest case drain or vent port. Use clean filtered fluid. A pump of this construction relies on the oil it is pumping to provide lubrication for its moving parts. Never run a piston pump dry, it will be instantly damaged.

- 3) Ensure all hoses, fittings, and couplers are tightened correctly.
- 4) Clean any oil spilled during assembly.
- 5) The RoadSaver system is equipped with shutoff valves in the suction circuits, check and be sure that all are open for flow.
- 6) Install a pressure gauge in the pressure line from the pump (this can be easily accomplished by installing a gauge into the test port in the bottom of the compensator. See compensator figure for test port location. Some valves may be equipped with a gauge port for this purpose, contact Etnyre International for details about the equipment you are working on.)

**IMPORTANT NOTE:** Failure to use proper adaptors or properly rated test equipment can cause component failure or personal bodily injury. Contact Etnyre International for the proper adaptor to install a gauge in the compensator or any other hydraulic test equipment you might need.

- 7) Loosen both set screws on the compensator (90 degrees from the adjustment screws).
- 8) Using an Allen wrench, turn the maximum pressure adjustment screw on the pump compensator counter clockwise until it turns freely but is still has sufficient thread engagement.

**IMPORTANT NOTE:** New and rebuilt pumps are tested for performance at very high pressure; failure to adjust this pressure to match your system requirements may cause component failure, hoses to rupture, and personal bodily injury.

- 9) Since air has been introduced into the suction side of the hydraulic system either because this is the first time starting or because of replacing the pump, the air must be bled off to allow pump fluid to be pumped. Air will not automatically flow through because the valve has a closed center design, meaning that no fluid flows unless a function is activated. Bleeding air can be accomplished in a number of different ways, either by directing the main pressure line back to the reservoir, by loosening the main pressure line fitting until pump fully primes, or by activating a free flowing circuit.

**IMPORTANT NOTE:** Loose connections or lines can be extremely dangerous, as can be hydraulic fluid under pressure. Take extreme caution to prevent injuries during this process.

- 10) Start the Cummins engine.
- 11) Allow pump to run for a few moments and fully prime.
- 12) Shut the system down, re-assemble any hoses or connection changed during step 9

**HYDRAULIC PUMP COMMISSIONING INSTRUCTIONS**

(Continued from previous page)

Before performing adjustments, read safety disclaimer.

- 13) (Control settings instructions from page 7) Install a pressure gauge in port M1 to measure system pressure.  
Tee-in a gauge to the LS/remote PC signal line (port X).
- 14) Start the engine and allow fluid to reach normal operating temperature.
- 15) Loosen the LS set screw. While watching the pressure gauges, turn the LS adjusting plug until 400 PSI is achieved. Clockwise rotation increases the setting, counterclockwise rotation will decrease it; approximate gain = 17 bar [250 psi] per turn. **(The LS setting should be 27 bar or 400 PSI.)**
- 16) While holding the position of the LS adjusting plug, torque the LS set screw to 7.5 - 10.8 N•m [5.5-8 lbf•ft].
- 17) Operate a hydraulic function to its full extension loading the pump at maximum pressure and zero flow.
- 18) Loosen the PC set screw and turn the PC adjusting plug until the desired setting is indicated on the pressure gauge at port M12. Clockwise rotation increases pressure, counterclockwise rotation decreases it; approximate gain = 42 bar [610 psi] per turn.
- 19) While holding the position of the PC adjusting plug, torque the PC set screw to 7.5 - 10.8 N•m [5.5-8 lbf•ft].
- 20) Stop the engine, remove the pressure gauges, and return the system to its normal operating configuration.

**IMPORTANT NOTE:** If you do **not** know the proper setting for maximum system pressure, contact technical support at Etnyre International .

**IMPORTANT NOTE:** Erratic operation may indicate there is still air trapped in the system. By working control valves both ways the remaining air can be eliminated. The system is free of air when all functions can be operated smoothly and the oil in the reservoir shows no foam on the surface.

**RS-E (Equalizer) Identified as a two pump system.**

Manifold Pump is Pressure compensated only.  
Pressure Compensation is set to 1800 PSI.

JS/PM pump is Pressure compensated with Load Sensing.  
Load Sensing is set to 400 PSI.  
Pressure Compensation is set to 3500 PSI.

**RS (RoadSaver) Identified as a three pump system.**

Manifold Pump is Pressure compensated only.  
Pressure Compensation is set to 1800 PSI.

JS pump is Pressure compensated with Load Sensing.  
Load Sensing is set to 400 PSI.  
Pressure Compensation is set to 2800 PSI.

PM pump is Pressure compensated with Load Sensing.  
Load Sensing is set to 400 PSI.  
Pressure Compensation is set to 4200 PSI.



# Constant Innovation Consistent Evolution